



AGENDA

FREDERICK COUNTY BOARD OF SUPERVISORS
WEDNESDAY, APRIL 24, 2019
7:00 P.M. - REGULAR MEETING
BOARD ROOM, COUNTY ADMINISTRATION BUILDING
107 NORTH KENT STREET, WINCHESTER, VIRGINIA

1. 7:00 P.M. - Regular Meeting Call to Order
2. Invocation
3. Pledge of Allegiance
4. Adoption of Agenda
5. Citizen Comments – Agenda Items that are not the subject of a Public Hearing
6. Consent Agenda (Roll Call Vote Required) Attachment
 - 6.A Minutes
 1. Regular Meeting of April 10, 2019 ----- A
 - 6.B Committee Reports
 1. Finance Committee Report of 4/17/19 ----- B
 2. Human Resources Committee Report of 4/12/19 ----- C
 - 6.C Request from the Commissioner of the Revenue for Refunds and Corresponding Supplemental Appropriations ----- D
 1. D L Peterson Trust- \$16,438.37
 2. J B Hunt Transport Inc - \$5,629.33
 3. Ryder Truck Rental LT- \$5,266.20
 4. Undisclosed Taxpayer- Disabled Veteran's Relief- \$2,595.79

7. **Board of Supervisors Comments**

8. **County Officials**

8.A **Presentation of Resolution of Appreciation to June Wilmot**

8.B **Committee Appointments** ----- E

1. Handley Regional Library Board
Unexpired 4-year term ending 11/30/19
2. Extension Leadership Council - Back Creek District
Unexpired 4-year term ending 1/14/20 – (See attached application of Brandon H. Monk)

9. **Committee Business**

9.A **Finance Committee** (See Attachment B for more info)

Items 1 – 4 were approved under Committee consent agenda.

1. The Sheriff requests a General Fund supplemental appropriation in the amount of \$34,576.31. This amount represents a reimbursement from the Secret Service. No local funds required. **Approved on Committee Consent Agenda.**
2. The Sheriff request a General Fund supplemental appropriation in the amount of \$19,561.75. This amount represents an auto insurance claim for equipment. No local funds required. **Approved on Committee Consent Agenda.**
3. The VJCCCA requests a General Fund budget transfer in the amount of \$23,000 from salaries to client services. No local funds required. **Approved on Committee Consent Agenda.**
4. The Deputy County Administrator requests a General Fund supplemental appropriation in the amount of \$5,524.38. This amount represents an insurance reimbursement for vandalism at the Old Frederick County Middle School. No local funds required. **Approved on Committee Consent Agenda.**
5. The Victim Witness Program Manager requests a General Fund budget transfer in the amount of \$17,039 from fringe benefits to various operating line items. No local funds required. **The Committee recommends approval.**

9.A Finance Committee, continued

6. The Social Services Director requests a General Fund budget decrease in the amount of \$340,500. Of this amount, \$53,298 are local dollars. The reduction represents yearend adjustments to bring the County budget in line with the State budget. **The Committee recommends approval.**
7. The Fire & Rescue Chief requests an F&R Expense Recovery Fund (Fund 30) supplemental appropriation in the amount of \$458,144. This amount represents revenue expected to be received in excess of budgeted revenue. No local funds are required. **The Committee recommends approval.**

9.B Human Resources Committee (See Attachment C for more info)

1. The Human Resources Department presented recommended changes to Frederick County Human Resources policy regarding Dismissal. **The Committee recommends approval.**
2. The Human Resources Department presented recommended changes to Frederick County Human Resources policy regarding Verification of Employment and References. **The Committee recommends approval.**

9.C Public Safety Committee

1. The Board of Supervisors referred the draft Emergency Response Performance Guide to ----- **F** the Chief's Working Group for consideration and review prior to Board action. The Chief's Working Group unanimously endorsed the Emergency Response Performance Guide. **The Committee recommends adoption of the Performance Guide.**

10. Public Hearings (Non Planning Issues)

**10.A Outdoor Festival Permit- Curves to Core National Hog Rally ----- G
June 19 to June 22, 2019**

Pursuant to the Frederick County Code, Chapter 86, Festivals; Section 86-3, Permit Required; Application; Issuance or Denial; Fee, for an Outdoor Festival Permit. Festival to be Held on Wednesday, June 19, 2019, from 8:30 AM to 6:00 PM; Thursday, June 20, 2019, from 8:30 AM to 9:00 PM; Friday, June 21, 2019, from 8:30 AM to 6:00 PM and Saturday, June 22, 2019, from 8:30 AM to 7:00 PM, on the Grounds of Grove's Winchester Harley-Davidson, 140 Independence Drive, Winchester, Virginia, Shawnee Magisterial District. Property Owned by Jobalie, LLC.

10. **Public Hearings (Non Planning Issues)**, continued

10.B Outdoor Festival Permit -Vintage Bikes and Swap Meet ----- H
June 15, 2019 (Rain date June 29, 2019)

Pursuant to the Frederick County Code, Chapter 86, Festivals; Section 86-3, Permit Required; Application; Issuance or Denial; Fee, for an Outdoor Festival Permit. Festival to be Held on Saturday, June 15, 2019, from 10:00 AM to 5:00 PM, (Rain Date to be Held on Saturday, June 29, 2019, from 10:00 AM to 5:00 PM), on the Grounds of Grove's Winchester Harley-Davidson, 140 Independence Drive, Winchester, Virginia, Shawnee Magisterial District. Property Owned by Jobalie, LLC.

10.C Twelve Month Outdoor Festival Permit Request - Cedar Creek ----- I
Battlefield Foundation (Patrick Kehoe).

Pursuant to the Frederick County Code, Chapter 86, Festivals; Section 86-3, Permit Required; Application; Issuance or Denial; Fee; Paragraph D, Twelve Month Permits. All Events to be Held on the Grounds of Cedar Creek Battlefield Foundation, 8437 Valley Pike, Middletown, Virginia, Back Creek Magisterial District. Property Owned by Cedar Creek Battlefield Foundation.

10.D Ordinance to Amend the Frederick County Code, Chapter 155, ----- J
Taxation, to Add an Article III-A Exemption for Surviving Spouses
of Certain Persons Killed in the Line of Duty.

The Purpose of this Proposed Amendment would Allow for an Exemption from Real Property Taxes for Surviving Spouses of Certain Public Safety Personnel Killed in the Line of Duty.

11. **Planning Commission - Public Hearings** –
None scheduled.

12. **Other Planning Business**

12.A Site Plan (Subdivision) #23-18, Liberty Chase ----- K
-- 17 Lot Townhouse Subdivision

The Applicant previously received a waiver of the Master Development Plan (MDP) requirement on July 10, 2017 and has chosen to process a subdivision design plan (site plan) in lieu of the MDP. When processing a subdivision design plan in lieu of the MDP, the Application must be presented to the Planning Commission and the Board of Supervisors as an informational item. Following its presentation to the Planning Commission and the Board of Supervisors, Staff will proceed with approval of the plan. This Application is presented for information; no action is necessary.

13. **Board Liaison Reports**

14. **Citizen Comments**

15. **Board of Supervisors Comments**

16. **Adjourn**

A

MINUTES
CLOSED SESSION AND REGULAR MEETING
FREDERICK COUNTY BOARD OF SUPERVISORS
WEDNESDAY, APRIL 10, 2019
6:00 P.M. AND 7:00 P.M.
BOARD ROOM, COUNTY ADMINISTRATION BUILDING
107 NORTH KENT STREET, WINCHESTER, VIRGINIA

ATTENDEES

Board of Supervisors: Charles S. DeHaven, Jr., Chairman; Gary A. Lofton, Vice Chairman; Blaine P. Dunn; J. Douglas McCarthy; Judith McCann-Slaughter; Shannon G. Trout and Robert W. Wells were present.

Staff present: Kris C. Tierney, County Administrator; Jay E. Tibbs, Deputy County Administrator; Roderick B. Williams, County Attorney; Cheryl Shiffler, Director of Finance; Jennifer Place, Budget Analyst; Karen Vacchio, Public Information Officer; Mike Marciano, Human Resources Director; Dennis Linaburg, Fire and Rescue Chief; Lenny Millholland, Sheriff; and Ann W. Phillips, Deputy Clerk to the Board of Supervisors.

CALL TO ORDER

Chairman DeHaven called the meeting to order at 6:00 p.m.

CLOSED SESSION

Vice Chairman Lofton moved that the Board convene in closed session pursuant to Section 2.2-3711 A (3) for discussion or consideration of the disposition of real property, where discussion in an open meeting would adversely affect the bargaining position or negotiating strategy of the public body. Supervisor Dunn seconded the motion which carried on a voice vote.

At 6:15 p.m., the Board members being assembled within the designated meeting place in the presence of members of the public and the media desiring to attend, the meeting was reconvened on motion of Vice Chairman Lofton, seconded by Supervisor Trout. Vice Chairman Lofton moved that the Board of Supervisors of Frederick County certify that, to the best of each member's knowledge, (i) only public business matters lawfully exempted from open meeting requirements by Virginia law were discussed in the closed meeting to which this certification applies, and (ii) only such public business matters as were identified in the motion convening the closed meeting were heard, discussed, or considered by the Board. Supervisor Trout seconded the motion which carried as follows on a roll call vote:

Blaine P. Dunn	Aye	Shannon G. Trout	Aye
Gary A. Lofton	Aye	Robert W. Wells	Aye
J. Douglas McCarthy	Aye	Charles S. DeHaven, Jr.	Aye
Judith McCann-Slaughter	Aye		

Vice Chairman Lofton moved that the Board authorize the County Administrator to execute on behalf of the County a contract for the sale of the Old Frederick County Middle School property, 441 Linden Drive, in the City of Winchester, Tax Map ID #130-01-1, to HD Partners, LLC, consistent with the discussion of the Board in its closed session just concluded. Supervisor McCarthy

seconded the motion which carried as follows on a roll call vote:

Blaine P. Dunn	Aye	Shannon G. Trout	Aye
Gary A. Lofton	Aye	Robert W. Wells	Aye
J. Douglas McCarthy	Aye	Charles S. DeHaven, Jr.	Aye
Judith McCann-Slaughter	Aye		

At 6:17 p.m., Chairman DeHaven recessed the meeting until 7:00 p.m.

CALL TO ORDER

Chairman DeHaven called the meeting to order at 7:00 p.m.

INVOCATION

Supervisor Wells delivered the invocation.

PLEDGE OF ALLEGIANCE

Vice Chairman Lofton led the Pledge of Allegiance.

ADOPTION OF AMENDED AGENDA - APPROVED

Upon motion of Vice Chairman Lofton, seconded by Supervisor Dunn, the agenda was adopted on a voice vote as amended by the removal of the item entitled Northern Y Revenue Sharing.

CITIZENS COMMENTS

The speakers were as follows:

Michael Holly, representing the Clorox Company, discussed his company's proposed cat litter manufacturing facility. He noted an upcoming community meeting that will allow residents to ask questions.

Rick Brown, Back Creek District, referenced a proposed low-cost housing project saying such developments result in higher demand on 911 services and additional children in the schools. He urged the Board not to rezone industrial land for residential purposes.

Charlie Gardner, Stonewall District, said he opposes anything to do with the Clorox company. He noted concerns about traffic, truck noise at night, dust and light concerns at the current Carmeuse quarry and said new development at the site will ruin the community.

Chris Jenkins, Stonewall District, discussed safety concerns for the Clear Brook fire and rescue personnel. He noted the Board's earlier discussion about realigning Brucetown Road, I-81 improvements, and relocation of the fire house. He said the traffic congestion and intersection problems should be addressed and said the Board could require Clorox to contribute to a new building for the fire hall.

Brenda Fristoe, Stonewall District, said the Clorox facility is not the answer to transportation problems. She referenced the 2035 Comprehensive Plan and asked the Board to follow that plan and vote no on a proposed cat litter facility.

Richard Kennedy, Shawnee District resident and representative of the Top of Virginia Chamber of Commerce, said both the local chamber and the state chamber are in support of the

Clorox proposal for a cat litter manufacturing facility.

Arthur Bragg, Stonewall District, said the Clorox community meeting is happening too late in the process. He noted his petition submitted earlier and said Clorox needs to look elsewhere. He noted noise and light concerns and invited the Board to visit and see the condition of Brucetown Road.

Lora Jarrell, Opequon District, said there is a misconception that retirees are the only ones on a fixed income. She said sacrifice is necessary for funding the public schools and asked the Board to listen to all constituents and not only those with the same viewpoint as their own.

Mark Georgiana, Stonewall District, noted the traffic concerns on Brucetown Road. He said he was a former Carmeuse employee and noted an earlier proposal to change the quarry entrance to Route 11 instead of Brucetown Road which could alleviate some traffic concerns.

Kenneth Burcham, Stonewall District, noted his concern about the Clorox proposal. He asked where the funding for the roads would come from. He noted concerns about waste products and water issues.

Greg McFarland, Stonewall District, said the citizens do not want the Clorox facility. He noted concerns about traffic and the current waste pile at Carmeuse and said other problems will arise if the cat litter facility is allowed to be built.

Lynelle McFarland, Stonewall District, said it was highly suspicious that a front-page article on the Clorox proposal appeared in the Winchester Star this week. She said the residents chose to live in a rural area rather than an industrial area. She questioned how gas lines on the subject property were funded. She said decisions a long time ago allowed Carmeuse to damage the community and asked the Board to remember that all decisions will impact the residents.

Amanda Feaster, Shawnee District, spoke in favor of keeping the real estate tax rate at \$0.61 per \$100 of assessed value. She referenced school support staff needing salary increases and the need for School Resource Officers for each school building and said a tax increase should be discussed to address funding shortages.

The Rev. Heidi David Young, Gainesboro District, quoted Martin Luther. She noted the requested public safety positions that are not funded in the current budget, and said she is concerned and frustrated that public safety and schools are not fully funded. She said the current path is self-defeating and asked the Board to change course.

Mary Meredith, Stonewall District, asked the Board to vote against changing a rural piece of land to an industrial use. She said the proposed project is not what Brucetown needs citing road safety and traffic concerns.

Jennifer Hall, Shawnee District, spoke in favor of the Blackburn workforce housing project. She said she is Director of Community Engagement at the United Way leading the Valley Assistance Network and is also a member of the steering committee for the Northern Shenandoah Valley Housing Coalition. She noted current entry level salaries and said the current affordable housing crisis makes the proposed project necessary for the County.

Joseph Jablonski, Red Bud District, said he is the Volunteer Coordinator for the Valley Assistance Network. He spoke in favor of the Blackburn workforce housing project.

Evan Wyatt of Greenway Engineering spoke in favor of the comprehensive plan amendment that would allow the Blackburn workforce housing project to progress. He asked that the request be forwarded to public hearing.

Shawn Graber, Back Creek District, asked the Board not to move forward with the current budget proposal. He asked the Board to trim the budget so that the real estate tax rate would not have to go up, saying that spending has gone up. He said he prefers that the Board slow down and pay for projects as they are done.

+ + + + + + + + + + + + + + + +

ADOPTION OF CONSENT AGENDA – APPROVED

Upon motion of Vice Chairman Lofton, seconded by Supervisor Dunn, the consent agenda was adopted on a voice vote.

- Minutes: Regular Meeting of March 27, 2019 - CONSENT AGENDA APPROVAL
- Code & Ordinance Committee Report of 3/28/19 - CONSENT AGENDA APPROVAL, Appendix 1
- Public Works Committee Report of 3/26/19 - CONSENT AGENDA APPROVAL, Appendix 2
- Transportation Committee Report of 3/25/19 - CONSENT AGENDA APPROVAL, Appendix 3
- Summer & Holiday Meeting Schedule cancelling the second meeting during the months of June, July, August, November and December – CONSENT AGENDA APPROVAL

BOARD OF SUPERVISORS COMMENTS - None

COUNTY OFFICIALS:

COMMITTEE APPOINTMENTS - None

COMMITTEE BUSINESS:

CODE AND ORDINANCE COMMITTEE

AMENDMENT FREDERICK COUNTY CODE, CHAPTER 90 (FIRE PREVENTION AND PROTECTION), ARTICLE I (GENERAL PROVISIONS), TO CONFORM WITH MOST RECENT PRACTICES AND CHANGES TO THE VIRGINIA FIRE PREVENTION CODE - FORWARDED TO PUBLIC HEARING

Supervisor Trout said the proposed revisions update the County's adoption of the Virginia Statewide Fire Prevention Code (VSFPC) to add, delete, and update definitions as appropriate, update requirements relating to fire hydrants, and make provision for fire personnel-accessible key boxes for certain structures. She moved that the proposed ordinance amendment be set for public hearing with a recommendation of approval from the Committee. Supervisor McCarthy seconded the motion which carried on a voice vote.

AMENDMENT TO FREDERICK COUNTY CODE, CHAPTER 158 (VEHICLES AND TRAFFIC), ARTICLE II (STOPPING, STANDING, AND PARKING), SECTION 158-4 (GENERAL RESTRICTIONS), TO ADD PROVISION REGARDING VIOLATION OF PARKING RESTRICTIONS ON COUNTY-OWNED/OPERATED PROPERTY – FORWARDED TO PUBLIC HEARING

Supervisor Trout said the proposed amendment would restrict parking on County-owned or County-controlled property to parking that is consistent with any posted signs on the property, and the new subsection would further impose a fine for a violation of such parking restrictions. She moved that the proposed ordinance amendment be set for public hearing with a recommendation of approval from the Committee. Supervisor Dunn seconded the motion which carried on a voice vote.

+ + + + + + + + + + + + + + + +

PUBLIC HEARING

PROPOSED AMENDMENT TO THE FREDERICK COUNTY CODE, CHAPTER 155 TAXATION, ARTICLE XIV TRANSIENT OCCUPANCY TAX, SECTION 155-51 TAX IMPOSED – ADOPTED

Mr. Tibbs explained the request from the Tourism Board for the increase in the Transient Occupancy Tax. He said the proposed amendment would increase the Transient Occupancy Tax rate from its current rate of 2.5% to 3.5% with the Proposed Amendment would taking effect on July 1, 2019.

Chairman DeHaven opened the public hearing.

There were no speakers.

Chairman DeHaven closed the public hearing.

Supervisor Slaughter moved for adoption of the ordinance amending Chapter 155 Taxation, Article XIV Transient Occupancy Tax, from 2.5% to 3.5%. Supervisor Trout seconded the motion which carried on a roll call vote as follows:

| | | | |
|-------------------------|-----|-------------------------|-----|
| Blaine P. Dunn | Aye | Shannon G. Trout | Aye |
| Gary A. Lofton | Aye | Robert W. Wells | Aye |
| J. Douglas McCarthy | Aye | Charles S. DeHaven, Jr. | Aye |
| Judith McCann-Slaughter | Aye | | |

ORDINANCE

The Board of Supervisors of Frederick County, Virginia hereby ordains that, effective July 1, 2019, Section 155-51 (Tax imposed) of Article XIV (Transient Occupancy Tax) of Chapter 155 (Taxation) of the Code of Frederick County, Virginia be, and the same hereby is, amended by enacting an amended Section 155-151 (Tax imposed) of Article XIV (Transient Occupancy Tax) of Chapter 155 (Taxation) of the Code of Frederick County, Virginia, as follows (deletion is shown in ~~strike through~~ and addition is shown in **bold underline**):

CHAPTER 155 TAXATION
Article XIV Transient Occupancy Tax
§ 155-51 Tax imposed.

In addition to all other taxes of every kind now or hereafter imposed by law, there is hereby imposed and levied on each and every transient a tax equivalent to ~~2.5%~~ **3.5%** of the total amount paid for room rental by or for any such transient to any motel.

+ + + + + + + + + + + + + + + +

ADOPTION OF FISCAL YEAR 2019-2020 BUDGET AND APPROPRIATIONS AND SETTING OF 2019 TAX RATES –APPROVED

Supervisor Slaughter moved that that the Board adopt Budget and Tax Rate Resolution Option A. Supervisor Wells seconded the motion.

Supervisor Slaughter noted the proposed budget will fund a School Resource Officer in each school.

Supervisor Trout said more funds are needed and she is disappointed that the Board was not supportive of a tax increase. She said she would support the proposed tax rate and budget as a step in the right direction.

Vice Chairman Lofton said he could not support the proposed budget resolution because of the airplane tax rate and the lack of the requirement of categorical funding for the schools.

Supervisor Dunn discussed teacher salaries in Frederick County compared to surrounding jurisdictions, his support of additional school buses, and the fire and rescue needs. He said he supports exploring impact fees as an alternative to raising real estate taxes.

Supervisor McCarthy said he supports the budget dollar amounts but does not support the resolution options as presented. He said he would prefer a hybrid of the two options which would incorporate a line item for categorically funding school maintenance only.

Supervisor Wells referenced Supervisor Trout's previously noted concern about citizen input coming earlier in the budget process. He said services cost money and the County cannot continue to refuse to address critical needs, adding that nearby jurisdictions have higher taxes and the residents are continuing to live there. He said the County cannot remain in the past.

Budget and Tax Rate Resolution Option A was adopted on a roll call vote as follows:

| | | | |
|-------------------------|-----|-------------------------|-----|
| Blaine P. Dunn | No | Shannon G. Trout | Aye |
| Gary A. Lofton | No | Robert W. Wells | Aye |
| J. Douglas McCarthy | No | Charles S. DeHaven, Jr. | Aye |
| Judith McCann-Slaughter | Aye | | |

FY 2019-2020 BUDGET RESOLUTION

WHEREAS a notice of public hearing and budget synopsis has been published and a public hearing held on March 27, 2019, in accordance with Title 15.2, Chapter 25, Section 15.2-2506, of the Code of Virginia, 1950 as amended.

THEREFORE, BE IT RESOLVED by the Board of Supervisors of the County of Frederick, Virginia, that the budget for the 2019-2020 Fiscal Year as advertised in The Winchester Star on March 19, 2019, be hereby approved in the amount of \$463,535,656.

BE IT FURTHER RESOLVED that the County of Frederick budget for the 2019-2020 fiscal year be adopted and the funds appropriated as follows:

| | |
|---------------------------------|---------------|
| General Operating Fund | \$197,546,413 |
| Regional Jail Fund | 23,238,848 |
| Landfill Fund | 10,467,653 |
| Division of Court Services Fund | 576,649 |

| | |
|--|-------------|
| Shawneeland Sanitary District Fund | 1,295,215 |
| Airport Operating Fund | 1,756,556 |
| Lake Holiday Sanitary District Fund | 779,998 |
| EMS Revenue Recovery Fund | 1,803,958 |
| Economic Development Authority Fund | 631,802 |
| School Operating Fund | 175,981,549 |
| School Debt Service Fund | 16,726,869 |
| School Capital Projects Fund | 5,300,000 |
| School Nutrition Services Fund | 7,378,557 |
| School Textbook Fund | 3,126,049 |
| NREP Operating Fund | 5,985,540 |
| NREP Textbook Fund | 40,000 |
| Consolidated Services/Maintenance Fund | 3,600,000 |
| School Private Purpose Funds | 300,000 |
| County Capital Fund | 7,000,000 |

BE IT FURTHER RESOLVED that the Board of Supervisors of the County of Frederick, Virginia, does herein adopt the tax rates for the 2019 assessment year as follows:

Property Taxes – Rates per \$100 of assessed value

| | |
|----------|--|
| \$0.61 | Applied to real estate, including mobile homes |
| \$4.86 | Applied to personal property including business equipment |
| \$2.25 | Applied to personal property on one vehicle to volunteer firefighters that are approved and registered with the Frederick County Fire and Rescue Department |
| \$0.01 | Applied to aircraft |
| Zero tax | Applied to antique vehicles and mopeds |
| \$2.00 | On declining values to be applied to machinery and tools. The declining values are 60% for year one, 50% for year two, 40% for year three, and 30% for year four and all subsequent years. |
| \$2.00 | On apportioned percentage of book values to be applied to Contract Classified Vehicles and equipment |

Business and Professional Occupational License Rates

| | |
|--|------------------------------------|
| Contractors | \$0.16 per \$100 of gross receipts |
| Retail | \$0.20 per \$100 of gross receipts |
| Financial, Real Estate, and Professional Services | \$0.58 per \$100 of gross receipts |
| Repair, personal and business services and all other businesses and occupations not specifically listed or exempted in the County Code | \$0.36 per \$100 of gross receipts |
| Wholesale | \$0.05 per \$100 of purchases |

The tax rates for other businesses and occupations specifically listed in the County Code are also unchanged.

Other General Taxes

| | |
|-------------------------|--|
| Meals tax | 4% of gross receipts |
| Transient Occupancy tax | 3.5% of gross receipts |
| Vehicle License Taxes | \$25 per vehicle and \$10 per motorcycle |

Sanitary Landfill Fees

| | |
|------|--|
| \$50 | Per ton for commercial/industrial |
| \$45 | Per ton for construction demolition debris |
| \$20 | Per ton for municipal waste |
| \$38 | Per ton for municipal sludge |
| \$15 | Per ton for Miscellaneous Rubble Debris |

Shawneeland Sanitary District Taxes

| | |
|-------|-----------------|
| \$190 | Unimproved Lots |
| \$660 | Improved Lots |

Lake Holiday Sanitary District Taxes

| | |
|-------|------------------|
| \$678 | Buildable Lots |
| \$264 | Unbuildable Lots |

Lots owned by Lake Holiday Country Club, Inc.

| | |
|-----|-------------------------------------|
| \$0 | Buildable Lots and Unbuildable Lots |
|-----|-------------------------------------|

Star Fort Subdivision Taxes/Fees

\$60 Per Lot

Street Light Fees

Oakdale Crossing and Fredericktowne \$40 annually

Green Acres \$25 annually

BE IT FURTHER RESOLVED that appropriations are hereby authorized for the central stores fund, special welfare fund, comprehensive services fund, county health insurance fund, school health insurance fund, length of service fund, special grant awards fund, employee benefits fund, maintenance insurance fund, development project fund, sales tax fund, commonwealth sales tax fund, unemployment compensation fund, Forfeited Assets Program, Four-For-Life Funds, Fire Programs, and Economic Incentive funds equal to the total cash balance on hand at July 1, 2019, plus the total amount of receipts for the fiscal year 2019-2020. The County Capital Fund and Fire Company Capital appropriation will include the current year appropriation plus any unused funds at the end of the fiscal year 2019. The County Capital appropriation shall include funds transferred to other capital funds for classification purposes.

BE IT FURTHER RESOLVED that funding for all outstanding encumbrances at June 30, 2019, are re-appropriated to the 2019-2020 fiscal year to the same department and account for which they are encumbered in the 2018-2019 fiscal year.

BE IT FURTHER RESOLVED that the construction fund projects are appropriated as a carryforward in the amount that equals the approved original project cost, less expenditures and encumbrances through June 30, 2019.

+ + + + + + + + + + + + + + + +

PLANNING COMMISSION BUSINESS

CPPA #02-18 BRUCETOWN ROAD AREA AMENDMENT – FORWARDED TO PUBLIC HEARING

Ms. Perkins introduced the draft amendment to the Northeast Land Use Plan of the 2035 Comprehensive Plan. She said this amendment proposes to add 109 acres into the Sewer and Water Service Area (SWSA) and remove 109 acres from the SWSA, and also seeks to designate the 109 acres for industrial land uses. She discussed other text changes in the proposed amendment, and said staff is seeking direction from the Board of Supervisors as to whether this item is ready to be sent to public hearing, noting that staff and the Planning Commission are also seeking direction from the Board of Supervisors on the use of “should vs shall” in the amendment.

Supervisor Slaughter moved that CPPA #02-18 not be forwarded for public hearing, and further moved that any additional consideration of CPPA #02-18 be ended at the present time. Supervisor Wells seconded the motion.

Supervisor McCarthy agreed that many concerns have been voiced. He said he promised his constituents that he would hear all sides before making decisions and said he wished the matter to go to public hearing before the issue is decided.

Supervisor Wells discussed growth and the need for infrastructure. He said he does not like the idea of changing the comprehensive plan and rezoning land unnecessarily.

Vice Chairman Lofton said he believes in sending issues to public hearing. He said it is imperative to send this issue to public hearing, adding he wants more discussion.

Supervisor Dunn noted that a yes vote tonight only means the matter will go to public hearing for further discussion. He noted concerns about Brucetown Road.

Supervisor Trout said the matter should go to public hearing, adding that she does not have enough information to decide on the project tonight.

Supervisor Slaughter discussed the numerous public meetings held prior to the adoption of the 2035 Comprehensive Plan, and the reference to maintaining rural communities including Brucetown.

Vice Chairman Lofton said the Plan is a guiding document and is routinely updated and changed.

Supervisor Slaughter's motion to not send CPPA # 02-18 to public hearing failed on a roll call vote as follows:

| | | | |
|-------------------------|-----|-------------------------|-----|
| Blaine P. Dunn | No | Shannon G. Trout | No |
| Gary A. Lofton | No | Robert W. Wells | Aye |
| J. Douglas McCarthy | No | Charles S. DeHaven, Jr. | Aye |
| Judith McCann-Slaughter | Aye | | |

Vice Chairman Lofton moved that CPPA # 02-18 be forwarded to public hearing. Supervisor Dunn seconded the motion which carried on a roll call vote as follows:

| | | | |
|-------------------------|-----|-------------------------|-----|
| Blaine P. Dunn | Aye | Shannon G. Trout | Aye |
| Gary A. Lofton | Aye | Robert W. Wells | No |
| J. Douglas McCarthy | Aye | Charles S. DeHaven, Jr. | No |
| Judith McCann-Slaughter | No | | |

RESOLUTION DIRECTING THE PLANNING COMMISSION TO HOLD A PUBLIC HEARING TO
ADOPT AN AMENDMENT TO THE
2035 COMPREHENSIVE PLAN
APPENDIX I – AREA PLANS
NORTHEAST LAND USE PLAN

WHEREAS, the 2035 Comprehensive Plan, was adopted by the Board of Supervisors on January 25, 2017 and this proposed amendment to the Northeast Land Use Plan of Appendix I would result in a land use designation change for (PIN) 34-A-24D from rural areas land use to industrial land use and expand the Sewer and Water Service Area (SWSA) to include 109 acres of parcel in the SWSA and remove 109 acres from the existing SWSA, and

WHEREAS, the Frederick County Planning Commission discussed this amendment on March 6, 2019 and sent the amendment to the Board of Supervisors for discussion; and

WHEREAS, the Frederick County Board of Supervisors discussed this proposed amendment on April 10, 2019; and

NOW, THEREFORE, BE IT REQUESTED by the Frederick County Board of Supervisors that the Frederick County Planning Commission shall hold a public hearing to consider an amendment to the Northeast Land Use Plan to amend the land use designation for PIN 34-A-24D from Rural Areas land use to Industrial land use and expand the Sewer and Water Service Area (SWSA) to include 109 acres of parcel in the SWSA and remove 109 acres from the existing SWSA and forward a recommendation to the Board of Supervisors.

+ + + + +

CPPA #01-19 BLACKBURN PROPERTY WORKFORCE HOUSING - FORWARDED TO PUBLIC HEARING

Ms. Perkins said this draft amendment to the Kernstown Area Plan of the 2035 Comprehensive Plan proposes to add 71.849-acres to the Urban Development Area (UDA). She said the amendment also seeks to designate the 71-acres for workforce housing. She added the Kernstown Area Plan currently designates the property for industrial land use and the Applicant is requesting the UDA expansion and land use designation change to allow for the development of workforce housing that would provide affordable housing opportunities for residents of the community. Ms. Perkins said the Planning Commission agreed with the concerns expressed by the CPPC and did not support the loss of planned industrial land for the construction of residential units, and therefore has sent this item forward to the Board of Supervisors with a recommendation for denial. She said staff is seeking

direction from the Board of Supervisors as to whether this item is ready to be sent forward for public hearing.

Vice Chairman Lofton moved to send CPPA # 01-19 forward to public hearing. Supervisor Trout seconded the motion.

Supervisor McCarthy said there needs to be an overriding reason to change the Comprehensive Plan and a public hearing will allow the Board to learn more before deciding on the matter.

Supervisor Dunn noted the property has been for sale for several years and is partly wetlands.

Vice Chairman Lofton agreed saying the mitigation of the wetland condition is expensive and housing is the highest and best use of the land.

Supervisor Wells said he does not like changing the Comprehensive Plan. He said adding residential development will have a financial impact on fire and rescue services and schools.

Supervisor Slaughter agreed with Supervisor Wells' concern about adding homes. She said out of respect for the Supervisor in whose district the project is located, she would be in favor of the matter going to public hearing.

Supervisor Trout said she is supportive of the workforce housing project and is in favor of sending matter to public hearing.

CPPA # 01-19 was forwarded to public hearing on a roll call vote as follows:

| | | | |
|-------------------------|-----|-------------------------|-----|
| Blaine P. Dunn | Aye | Shannon G. Trout | Aye |
| Gary A. Lofton | Aye | Robert W. Wells | Aye |
| J. Douglas McCarthy | Aye | Charles S. DeHaven, Jr. | Aye |
| Judith McCann-Slaughter | Aye | | |

RESOLUTION DIRECTING THE PLANNING COMMISSION TO HOLD A PUBLIC HEARING TO
ADOPT AN AMENDMENT TO THE
2035 COMPREHENSIVE PLAN
APPENDIX I – AREA PLANS
KERNSTOWN AREA PLAN

WHEREAS, the 2035 Comprehensive Plan, was adopted by the Board of Supervisors on January 25, 2017 and this proposed amendment to the Kernstown Area Plan of Appendix I would result in a land use designation change for (PIN) 63-A-80I from industrial land use to workforce housing and expand the Urban Development Area (UDA) to include 71.849-acres to the UDA; and

WHEREAS, the Frederick County Planning Commission discussed this amendment on March 6, 2019 and sent the amendment to the Board of Supervisors with a recommendation for denial; and

WHEREAS, the Frederick County Board of Supervisors discussed this proposed amendment on April 10, 2019; and

NOW, THEREFORE, BE IT REQUESTED by the Frederick County Board of Supervisors that the Frederick County Planning Commission shall hold a public hearing to consider an amendment to the Kernstown Area Plan to amend the land use designation for PIN 63-A-80I from industrial land use to Workforce Housing and expand the Urban Development Area (UDA) to include 71.849 acres and forward a recommendation to the Board of Supervisors.

+ + + + +

BOARD LIAISON REPORTS

Vice Chairman Lofton reported the Extension Leadership Council was currently recognizing Volunteer Week. He announced that 4-H camp will be held July 7-11 at the Northern Virginia 4-H Center.

Supervisor Wells thanked the Public Works Department staff, especially those at the landfill, for a successful Solid Waste Forum event held recently.

Chairman DeHaven said he had received very positive feedback about the event.

CITIZEN COMMENTS

George Sempeles, Red Bud District, noted that in 2001 the County denied a technology center development and subsequently 800 homes were built instead. He said industry pays the bills and he would like to see the Clorox project go through.

Joy Kirk, Back Creek District, said she is tired of the schools having to ask only for critical needs. She discussed tax increases and asked when the County will move forward and fund the future.

Brian Nuri, Opequon District, thanked the Board for adopting the budget. He said he is concerned about infrastructure and discussed traffic and road concerns that he wants the Board to address. He said he does not see fat in the budget, but he wants the County to start catching up on the needs.

BOARD OF SUPERVISORS COMMENTS

Supervisor Trout noted the recently held Trail Race for Autism at Sherando Park.

Supervisor Dunn said the current Board members were not in office 15 to 20 years ago when much of the current growth was approved. He said the Board continues to look for ways to solve problems.

Supervisor McCarthy gave a reminder of the upcoming Apple Blossom Festival.

NOISE ORDINANCE REFERRED TO CODE AND ORDINANCE COMMITTEE

Supervisor Slaughter noted a recurring problem with noise in her District saying she would like the County Code to be amended to align with the most recent Virginia Supreme Court decision enabling law enforcement to better address residents' concerns. She moved that the Board refer the matter to the Code and Ordinance Committee to revisit proposed revisions to County Code Chapter 118 regarding enforceability. Supervisor Dunn seconded the motion which carried on a voice vote.

ADJOURN

On motion of Vice Chairman Lofton, seconded by Supervisor Dunn, the meeting was adjourned at 9:00 p.m.

B

FINANCE COMMITTEE & AUDIT COMMITTEE REPORT to the BOARD OF SUPERVISORS
Wednesday, April 17, 2019
8:00 a.m.
107 NORTH KENT STREET, WINCHESTER, VIRGINIA

A Finance Committee meeting was held in the First Floor Conference Room at 107 North Kent Street on Wednesday, April 17, 2019 at 8:00 a.m.

ATTENDEES:

Committee Members Present: Judith McCann-Slaughter, Chairman; Charles DeHaven; Gary Lofton; Jeffrey Boppe; Angela Rudolph-Wiseman; and William Orndoff (non-voting liaison).

Committee Members Absent: Ellen Murphy, Commissioner of the Revenue (non-voting liaison).

Staff present: Cheryl Shiffler, Finance Director; Sharon Kibler, Assistant Finance Director; Kris Tierney, County Administrator; Jay Tibbs, Deputy County Administrator; Rod Williams, County Attorney; Lenny Millholland, Sheriff; Denny Linaburg, F&R Chief; Melissa Rice, Victim Witness Program Manager; Jennifer Place, Budget Analyst; Delsie Jobe, DSS Administrative Services Manager; Melissa Neal, F&R Administrative Assistant; and Christine Bauserman, EMS Billing Manager.

ITEMS REQUIRING ACTION BY BOARD OF SUPERVISORS:

Items 1 – 4 were approved under consent agenda.

1. The Sheriff requests a General Fund supplemental appropriation in the amount of \$34,576.31. This amount represents a reimbursement from the Secret Service. No local funds required. See attached information, p. 3 – 4.
2. The Sheriff request a General Fund supplemental appropriation in the amount of \$19,561.75. This amount represents an auto insurance claim for equipment. No local funds required. See attached information, p. 5 – 6.
3. The VJCCA requests a General Fund budget transfer in the amount of \$23,000 from salaries to client services. No local funds required. See attached memo, p. 7.
4. The Deputy County Administrator requests a General Fund supplemental appropriation in the amount of \$5,524.38. This amount represents an insurance reimbursement for vandalism at the Old Frederick County Middle School. No local funds required. See attached memo, p. 8 – 9.
5. The Victim Witness Program Manager requests a General Fund budget transfer in the amount of \$17,039 from fringe benefits to various operating line items. No local funds required. See attached information, p. 10 – 14. The committee recommends approval.
6. The Social Services Director requests a General Fund budget decrease in the amount of \$340,500. Of this amount, \$53,298 are local dollars. The reduction represents yearend adjustments to bring the County budget in line with the State budget. See the attached memo, p. 15 – 18. The committee recommends approval.
7. The Fire & Rescue Chief requests an F&R Expense Recovery Fund (Fund 30) supplemental appropriation in the amount of \$458,144. This amount represents revenue expected to be received in excess of budgeted revenue. No local funds are required. See attached memo, p. 19. The committee recommends approval.

INFORMATION ONLY:

1. The Finance Director provides a Fund 10 Transfer Report for March 2019. See attached, p. 20 – 21.
2. The Finance Director provides financial statements ending March 31, 2019. See attached, p. 22 – 32.
3. The Finance Director provides an FY 2019 Fund Balance Report ending April 12, 2019. See attached, p. 33.

Respectfully submitted,

FINANCE COMMITTEE

Judith McCann-Slaughter, Chairman
Charles DeHaven
Gary Lofton
Jeffrey Boppe
Angela Rudolph

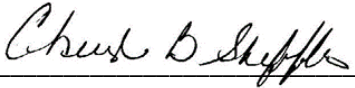
By 

Cheryl B. Shiffler, Finance Director

FREDERICK COUNTY SHERIFF'S OFFICE

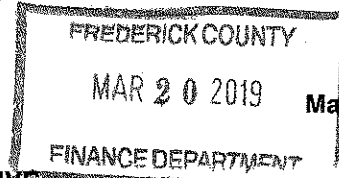

Sheriff Lenny Millholland

Major Steve A. Hawkins

1080 COVERSTONE DRIVE
WINCHESTER, VIRGINIA 22602

540-662-6168
FAX 540-504-6400

To : Cheryl Shiffler, Director of Finance
From : Sheriff Lenny Millholland
Subject : Reimbursements - Appropriation
Date : March 21, 2019

Frederick County Sheriff's Office has received reimbursements from the Secret Services totaling \$34,576.31. This amount has been posted to 3-010-033010-0025. We are requesting appropriation into the following budget lines items:

\$15,736.19 – Overtime - 3102-1005-000-000

\$18,840.12 – Travel – 3102-5506-000-000

Total = \$34,576.31

Thank you.

LWM/adl

C.S. 2/21/19 \$21,725.38
1/30/19 \$11,910.57
3/8/19 \$ 940.36

\$ 34,576.31

(revenue not budgeted)

Angela Lineweaver

3010-033010-0025

From: Dave Ellinger
Sent: Monday, March 18, 2019 3:56 PM
To: Angela Lineweaver
Subject: Funds Transfers
Attachments: scan0002.pdf

I have attached the reimbursements received form the IRS for our travel and overtime that covers the fist six months, July thru December 2018. Here is the breakdown of funds that you need to request a transfer for.

Received: \$34,576.31

Funds to go to Overtime - 1005: \$15,736.19

Funds to go to Travel - 5506: \$18,840.12

| Date | Deposit | Overtime - 1005 | Travel - 5506 | Month |
|-----------|-------------|-----------------|---------------|-----------|
| 2/21/2019 | \$12,415.13 | \$3,745.14 | \$8,669.99 | July |
| 2/21/2019 | \$3,956.48 | \$827.40 | \$3,129.08 | August |
| 2/21/2019 | \$5,353.77 | \$827.40 | \$4,526.37 | September |
| 1/30/2019 | \$5,059.40 | \$4,068.95 | \$990.45 | October |
| 1/30/2019 | \$6,851.17 | \$5,326.94 | \$1,524.23 | November |
| 3/8/2019 | \$940.36 | \$940.36 | \$0.00 | December |
| | \$34,576.31 | \$15,736.19 | \$18,840.12 | |

21,725.38
2/21/19
11,910.57
11/30/19

Thanks,

Dave

FREDERICK COUNTY SHERIFF'S OFFICE



Sheriff Lenny Millholland

Major Steve A. Hawkins

1080 COVERSTONE DRIVE
WINCHESTER, VIRGINIA 22602

540-662-6168
FAX 540-504-6400

TO : Cheryl Shiffler Director of Finance
FROM : Sheriff Lenny Millholland
DATE : April 10, 2019
SUBJECT : Insurance Reimbursement

We are requesting the insurance check received in the amount of \$19,561.75 for the auto claim dated December 14, 2018 involving Deputy Bradford be appropriated into the following line items. This amount is for items that has been damaged in the accident and needs to be replaced

3102-5401-000-000 – Office Supplies

Seiko MP-A40-BT-00A Mobile Printer - \$516.55
Datalogic MG112041-001-412B Scanner - \$239.45
Getac B300 Laptop - \$3,299.12 (replacement cost)
Total – \$4,055.12

3102-5408-000-000 – Vehicle/Power Equipment

Whelen Justice Lightbar - \$2,485.00
Motorola XTS 2500 Mobile Radio - \$6,946.63 (replacement cost)
Total - \$9,431.63

3102-5409-000-000 – Police Supplies

Intoximeter Alcosensor III - \$335.00
MPH Speed S Lidar - \$1,295.00
Decatur Responder 1000 - \$2,999.00
Kustom Signals Raptor RPI - \$1,446.00
Total - \$6,075.00

Grand total = \$19,561.75

Thank you

LWM/adl

3-010-018990-0001
c.s 3/25/19



VACORP

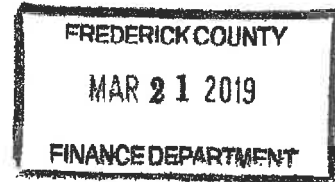

March 13th, 2019

Frederick County
Attn: Jennifer Place
107 North Kent Street
Winchester, VA. 22601

Virginia Association of Counties Self Insurance Risk Pool
Member: Frederick County
Claim Number: 0342018238410
Date of Loss: 12/14/2018

Dear Ms. Place:

Enclosed please find VACORP inland marine check in the amount of \$19,561.75 for the equipment damaged in an accident that occurred on 12/14/2018. This payment was based on the invoices/purchase orders submitted totaling \$20,061.75 less \$500.00 deductible.

If you should have any questions regarding this payment, please feel free to call me at 1-888-822-6772 ext. 174.

Sincerely,

Jared Mullen
Claims Specialist

Enclosed – Check

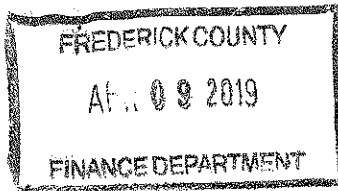

Andrew K. Block, Jr.
Director

Peter Roussos
COURT SERVICES DIRECTOR

26TH DISTRICT COURT
SERVICE UNIT
26 Rouss Ave., Suite 100
Winchester, VA 22601
(540) 722-7960
Fax: (540) 667-4818

COMMONWEALTH of VIRGINIA

Department of Juvenile Justice
Twenty-Sixth Judicial District Court Service Unit

SERVING:
Winchester City
Harrisonburg City
Clarke County
Frederick County
Page County
Rockingham County
Shenandoah County
Warren County

April 4, 2019

Ms. Cheryl Shiffler, Finance Director
107 North Kent Street
Winchester, Virginia

RE: Transfer of Funds

Dear Cheryl,

Please be advised that due to vacancies in our three VJCCCA funded positions with Frederick County, we would like to move \$23,000.00 from salaries (\$10,000.00 from Line Item 033030-1001-000-001, \$5,000.00 from Line Item 033030-1001-000-002 and \$8,000.00 from Line Item 033030-1003-000-000) to Supervision Plan Services (Line Item 033030-3002-000-004) to be utilized for services for our clients. No local funds will be needed as this money is solely from the VJCCCA grant.

Please feel free to contact me should you have any questions.

Respectfully,

Peter Roussos, Director
26th District Court Service Unit



COUNTY of FREDERICK

Jay E. Tibbs

Deputy County Administrator

540/665-5666

Fax 540/667-0370

E-mail:

jtibbs@fcva.us

| | |
|-----------------|---|
| TO: | Finance Committee |
| FROM: | Jay E. Tibbs, Deputy County Administrator  |
| SUBJECT: | Appropriation of Insurance Reimbursement |
| DATE: | April 8, 2019 |

Attached please find a copy of a check received from VACoRP in the amount of \$5,524.38 for a property claim dated February 16, 2009 in which vandals damaged property and equipment at the old Frederick County Middle School. Staff is seeking appropriation of these funds into the following budget line item 4-010-043040-3004-000-000 – Repair and Maintenance Buildings & Grounds.

Should you have any questions, please do not hesitate to contact me.

Attachment

3-010-018990-0001

c.s. 4/9/19



COUNTY of FREDERICK

Finance Department
Cheryl B. Shiffler
Director

540/665-5610
Fax: 540/667-0370
E-mail: cshiffle@fcva.us

MEMORANDUM

TO: Monica Ritenour, County Administrator's Office

FROM: Jennifer L. Place, Finance Department *JLP*

DATE: April 5, 2019

SUBJECT: Insurance Reimbursement

Attached is a copy of a check received from VACoRP in the amount of \$5,524.38 for the property claim dated February 16, 2019 in which vandals damaged property and equipment at the old Frederick County Middle School. This amount represents the estimates and invoices provided minus the \$1,000 deductible.

If you would like these funds appropriated to your budget, please send the Finance Department a memo requesting appropriation to forward to the Finance Committee.

If you have any questions, please give me a call.

Sharon Kibler

From: Melissa Rice
Sent: Tuesday, March 26, 2019 11:50 AM
To: Cheryl Shiffler
Cc: Sharon Kibler
Subject: Request of transfer - to Finance Committee
Attachments: SVictim Wit19031813130.pdf

I am requesting a transfer of funds from Fringe Benefits (\$17,039) – Health Insurance line item, due to my two full time employees currently do not use that money because they are insured by the spouses plans. I have provided DCJS with the proper paperwork and documentation which I have attached to explain the transfer – and line items and description of transfers. Could you please place this on the finance committee meetings agenda for discussion.

Thank you.

Melissa D. Rice, Director

Frederick County Victim Witness Program
107 North Kent Street, 4th Floor
Winchester, VA 22601
(540) 722-8200
Mrice@fcva.us

Budget Amendment

Narrative Form

A budget amendment allows you to move any portion of your award amount from one category to another.

The purpose of the narrative is to explain why the change is being requested and to itemize and justify the changes. In the form below, please indicate how much money you are requesting to move in a category and indicate if the request is increasing or decreasing the amount from the most recently approved budget. Then provide a justification and itemize all new requests. Once the form is completed it can be uploaded into GMIS to accompany the budget amendment request. Please, remember only two (2) budget amendment requests are allowed per grant year and require prior approval.

Personnel

Requesting to move: \$8,000.00

Increase or Decrease: Increase

Justification: Would like to hire a part-time staffing to help with scanning of documents and clerical duties, which have become extremely overwhelming here in our office. The staff would help to purge and archive any and all files that are past the three-year expungement. Also, staff would help to re-organize and help to make additional space, in an office where space has been maxed to compacity. We have been currently linked to our secure server and able to scan our documents to that server and make the office a paperless office, so that our room is used more efficiently. The plan is to hire Season Personnel, (i.e. college or intern students) that are looking for experience, and also to get paid for working in an professional office.

Fringe

Requesting to move: \$17,039.00

Increase or Decrease: Decrease

Justification: Decreased from Fringe Benefits line item Hospital/Medical expense. The two employees that I currently employ to not participate currently in the Hospital/Medical plan provided by the county, they insured by the spouses. This leaving a balance of \$20,000.00 in that line item, which I am requested be moved into other line items for expenditure.

Consultants

Requesting to move: \$

Increase or Decrease:

Justification:

Travel

Requesting to move: \$780.00

Increase or Decrease: Increase

Justification: Increase Travel by \$780.00 to pay for the flight to NOVA convention in Phoenix Arizona in July. Currently it is cheaper to book the flight now, then if we are to wait until July 1st to book the flight. I have the money and would to move the money so that we can save money in the long run. The NOVA conventions is a great networking convention and is where I have gotten the most knowledge and learn more about how people continue their education and work with victims and witnesses of crime.

Equipment

Requesting to move: \$4149.00

Increase or Decrease: Increase

Justification:

1. Purchase new printer – printer currently being used has been inspected by IT department and has been found to have a lever and spring broken inside the main compartment, which does allow for the paper to be feed to the machine. The cost of the parts would be approximately half of what a new printer would cost. A request is asked to purchase a new printer for the office. This printer is used to printer letters to witnesses and victims of crime, envelopes and forms, also all grants administrative work is printed on this printer – HP LaserJet M606. {\$1400.00}
2. Purchase new laptop – which will work with the data plan listed below, to assist in courtroom information, and providing all current and accurate information to victims and witnesses in court. We also use the computer to show case information that may be used in trial or during sentencing to prepare the victim/witness to what they may see while participating in the court hearing. We prepare Victim impact statements, restitution requests, Criminal Injuries Compensation Forms, and any additional forms that may be needed to be completed to assist and service victims and witnesses. IT has reviewed and priced it at {\$2500.00} all necessary items included.
3. Purchase new monitor – to replace/repair an old monitor that is used by our volunteer staff. {\$249.00}

Supplies and Other

Requesting to move: \$4,110.00

Increase or Decrease: Increase

Justification:

1. Outreach - Purchase advertisement, and promotional items to be used during exhibits and presentations. Outreach is a very important part of Victim Witness, we have very few opportunities to get out and when we do it is important that we give people our information and provide them with the opportunity to keep our phone numbers. It is also important for our information to be accessible through our appearance when at conferences, by wearing apparel that shows our locality, or while attending seminars or presentations. {\$2800.00}
2. Data plan – our offices are not located in the courthouse, so we have to take equipment with us to be able to access our computer from a remote server. This server has limit access and leaves us paralyzed in helping victims and witnesses while in the courtroom. So, we have no access to our information, court files and informational guides and forms while in the courtroom of the courthouse. With the

data plan the IT department will be able to give us access to each of our computers and allow us the ability to remain connected to our offices and have the tools and ability to services victims within the courtroom of the courthouse. {\$40.00 / month x 3 = \$120.00}

3. Purchase Standing Desk Riser – the ability to stand while working. This has become a request of an employee's due to lack of circulation in legs and would like the ability to stand some during the work day. (\$690.00 {\$230.00 each x 3})
4. Office Supplies – purchase additional office supplies, like envelopes and paper, and letterhead. {\$500.00}.

Additional Comments:

Our current employees do not participate in the Health Insurance Fringe Benefit, but future employees may, so keeping this amount available is a must. Each year this line item will need to be evaluated to see what portion has been spent, and then request for amendment may need to be made.

[Print Report](#)

Budget Amendment Request
 Department of Criminal Justice Services
 1100 Bank Street
 12th Floor
 Richmond, Virginia 23219
 Richmond, VA 23219

| | | |
|--------------------------------------|-----------------------------------|---|
| Subgrantee: Frederick | Grant Number: 19-W9261VW17 | |
| Title: Victim Witness Program | Date: 03-18-2019 | Status: Needs Finance Officer Approval |

| LATEST APPROVED BUDGET | | | | | | |
|------------------------|-------------------|-------------|------------------|-------------|-------------|-------------------|
| Budget Categories | DCJS Funds | | | Subgrantee | | Total Program |
| | Federal | State | Special | Cash | In Kind | |
| Personnel | 146,514.00 | 0.00 | 48,838.00 | 0.00 | 0.00 | 195,352.00 |
| Consultant | 0.00 | 0.00 | 0.00 | 0.00 | 0.00 | 0.00 |
| Travel | 2,414.00 | 0.00 | 805.00 | 0.00 | 0.00 | 3,219.00 |
| Equipment | 75.00 | 0.00 | 25.00 | 0.00 | 0.00 | 100.00 |
| Indirect Cost | 0.00 | 0.00 | 0.00 | 0.00 | 0.00 | 0.00 |
| Supplies/Other | 6,599.00 | 0.00 | 2,200.00 | 0.00 | 0.00 | 8,799.00 |
| Total Project | 155,602.00 | 0.00 | 51,868.00 | 0.00 | 0.00 | 207,470.00 |

| REVISED BUDGET REQUESTED | | | | | | |
|--------------------------|-------------------|-------------|------------------|-------------|-------------|-------------------|
| Budget Categories | DCJS Funds | | | Subgrantee | | Total Program |
| | Federal | State | Special | Cash | In Kind | |
| Personnel | 139,734.00 | 0.00 | 46,579.00 | 0.00 | 0.00 | 186,313.00 |
| Consultant | 0.00 | 0.00 | 0.00 | 0.00 | 0.00 | 0.00 |
| Travel | 2,999.00 | 0.00 | 1,000.00 | 0.00 | 0.00 | 3,999.00 |
| Equipment | 3,187.00 | 0.00 | 1,062.00 | 0.00 | 0.00 | 4,249.00 |
| Indirect Cost | 0.00 | 0.00 | 0.00 | 0.00 | 0.00 | 0.00 |
| Supplies/Other | 9,682.00 | 0.00 | 3,227.00 | 0.00 | 0.00 | 12,909.00 |
| Total Project | 155,602.00 | 0.00 | 51,868.00 | 0.00 | 0.00 | 207,470.00 |

[Budget Narrative: Amendment1.pdf](#)

Memo

To: Finance Committee/Cheryl Shiffler

From: Delsie D. Jobe *ddj*

CC: Tamara Green, Director

Date: April 11, 2019

Re: Appropriation adjustments

The attached spreadsheet contains seventeen (17) budget lines that need to be adjusted in order to bring our County budget in line with our State budget.

Of that seventeen, four (4) programs need to be reduced by a total of \$446,000, of which \$53,298 is a reduction in Local dollars. These programs had a decrease in caseloads in FY 2019. Six (6) other program budget lines need to be increased by a total of \$105,500. Four of these budget lines are State mandated programs and we spent our initial allocation and the State gave us additional funding. One of the programs we received additional State funding that reduced the local budgeted amount alone by \$47,200. The net of these adjustments results in a **decrease** of **\$340,500** of total dollars, of which **\$53,298** is local dollars.

The remaining seven (7) adjustments is to our administrative budget and we are requesting a budget transfer to reallocate funding from our salaries savings, due to vacant positions, in order to absorb additional cost in our overtime budget line. Additional we are requesting a transfer to reallocate funding for legal, non-legal, training and travel expenses for trainings and monthly out-of-state client visitations from our rent budget line. The net of these budget transfers is \$0.00.

No additional local dollars are needed.

Thank you for your consideration.

Delsie D. Jobe, Administrative Services Manager

**2018-2019 BUDGET INFORMATION - ORIGINAL BUDGET
FISCAL YEAR END 2018 APPROPRIATION ADJUSTMENTS**

| | <u>Original Budget</u> | <u>Debit</u> | <u>Credit</u> | <u>New Appropriation \$</u> |
|---|------------------------|--------------|---------------------------------|-----------------------------|
| 053170 - 5811-000 IV-E Foster Care | 600,000.00 | | 300,000.00 | 300,000.00 |
| 053170 - 5812-000 Adoption Subsidy | 740,000.00 | 70,000.00 | | 810,000.00 |
| 053170 - 5814-000 Fostering Futures IVE | 35,000.00 | 15,000.00 | | 50,000.00 |
| 053170 - 5817-000 Special Needs Adoption | 310,000.00 | | 50,000.00 | 260,000.00 |
| 053170 - 5829-000 Family Preservation | 6,933.00 | 5,100.00 | | 12,033.00 |
| 053170 - 5830-000 Child Welfare Substance Abuse | 12,000.00 | 4,000.00 | | 16,000.00 |
| 053170 - 5833-000 Adult Services | 122,000.00 | | 36,000.00 | 86,000.00 |
| 053170 - 5861-000 ILF Education/Training | 1,500.00 | 9,000.00 | | 10,500.00 |
| 053170 - 5862-000 Independent Living - Basic | 3,000.00 | 2,400.00 | | 5,400.00 |
| 053170 - 5872-000 VIEW Purchase Sevices | 122,000.00 | | 60,000.00 | 62,000.00 |
| <hr/> | | | | |
| 053160 - 1001-000 Salaries | 4,091,909.00 | | 16,000.00 | 4,075,909.00 |
| 053160 - 1005-000 On Call Compensation/OT | 29,700.00 | 16,000.00 | | 45,700.00 |
| 053160 - 3002-000 Contract Services - Legal | 95,000.00 | 24,000.00 | | 119,000.00 |
| 053160 - 3010-000 Contract Services - Non Legal | 66,200.00 | 5,000.00 | | 71,200.00 |
| 053160 - 5405-000 Training | 5,000.00 | 1,500.00 | | 6,500.00 |
| 053160 - 5506-000 Travel | 6,000.00 | 5,000.00 | | 11,000.00 |
| 053160 - 9002-000 Rent of Building | 250,000.00 | | 35,500.00 | 214,500.00 |
| | 6,496,242.00 | 157,000.00 | 497,500.00 | 6,155,742.00 |
| | | (340,500.00) | allocation decrease for FY 2019 | |

** These changes are to bring the county budget appropriations in alignment to our state budget appropriations.
No additional local dollars are needed.

2018-2019 BUDGET INFORMATION - FINAL REVISED BUDGET

| DEPARTMENT: Frederick Co. DSS - Administration | | | | |
|--|---------------------------------------|---------------------|------------------------|------------|
| EXPENDITURE
LINE ITEM | DESCRIPTION | Approved Budget | NEW Adjusted
Budget | Difference |
| 1001 | Salaries & Wages | 4,091,909.00 | 4,075,909 | 16,000 |
| 1005 | Extra help/overtime | 29,700.00 | 45,700 | (16,000) |
| 1006 | Compensation of Board members | 4,800.00 | 4,800 | - |
| 2001 | FICA | 317,193.00 | 317,193 | - |
| 2002 | VRS | 371,480.00 | 371,480 | - |
| 2005 | Health | 1,006,266.00 | 1,006,266 | - |
| 2006 | Group Life Insurance | 52,920.00 | 52,920 | - |
| 2008 | Short/Long-term Disability | 10,605.00 | 10,605 | - |
| 2009 | Unemployment | 10,000.00 | 10,000 | - |
| 2011 | Workers Comp | 10,293.00 | 10,293 | - |
| 3002 | Contract Services - Legal | 95,000.00 | 119,000 | (24,000) |
| 3005 | Maintenance Service Contracts | 15,500.00 | 15,500 | - |
| 3007 | Advertisement | 3,000.00 | 3,000 | - |
| 3010 | Contract Services - Not Legal | 66,200.00 | 71,200 | (5,000) |
| 4002 | Gasoline/Repairs - Vehicles | 25,000.00 | 25,000 | - |
| 5201 | Postage | 20,000.00 | 20,000 | - |
| 5202 | Telecommunications | 39,060.00 | 39,060 | - |
| 5300 | Insurance | 13,000.00 | 13,000 | - |
| 5401 | Office Supplies | 89,806.00 | 89,806 | - |
| 5505 | Training | 5,000.00 | 6,500 | (1,500) |
| 5506 | Travel | 6,000.00 | 11,000 | (5,000) |
| 5600 | Contribution Shelter for Abused Women | 6,000.00 | 6,000 | - |
| 5801 | Dues & Association Memberships | 3,000.00 | 3,000 | - |
| 8005 | Motor Vehicles & Equipment | 22,977.00 | 22,977 | - |
| 8007 | Integrated Tech Equipment | | - | - |
| 9001 | Lease/Rent of Equipment | 6,600.00 | 6,600 | - |
| 9002 | Lease/Rent of Building | 250,000.00 | 214,500 | 35,500 |
| | | | | |
| | TOTALS | 6,571,309.00 | 6,571,309 | - |

2018-2019 BUDGET INFORMATION - FINAL REVISED BUDGET

DEPARTMENT: Frederick Co. DSS - Public Assistance

DEPARTMENT CODE: 053170

| EXPENDITURE
LINE ITEM | DESCRIPTION | Approved Budget | NEW Adjusted
Budget | Difference | Local
match |
|--------------------------|--------------------------------|------------------|------------------------|----------------|----------------|
| 5804 | Auxiliary Grant | 90,000 | 90,000 | 0 | - |
| 5808 | Tanf Manual checks | 600 | 600 | 0 | - |
| 5811 | AFDC - Foster Care | 600,000 | 300,000 | 300,000 | - |
| 5812 | Adoption Subsidy | 740,000 | 810,000 | (70,000) | - |
| 5813 | General Relief | 10,000 | 10,000 | 0 | - |
| 5814 | Fostering Futures IVE | 35,000 | 50,000 | (15,000) | - |
| 5817 | Special Needs Adoption | 310,000 | 260,000 | 50,000 | - |
| 5819 | Refugee Resettlement | 0 | - | 0 | - |
| 5820 | Adoption Incentive | 3,000 | 3,000 | 0 | - |
| 5829 | Family Preservation | 6,933 | 12,033 | (5,100) | (791) |
| 5830 | Child Welfare Substance Abuse | 12,000 | 16,000 | (4,000) | (2,411) |
| 5833 | Adult Services | 122,000 | 86,000 | 36,000 | 47,200 |
| 5848 | TANF-UP Manual Checks | 400 | 400 | 0 | - |
| 5861 | ILF Education/Training | 1,500 | 10,500 | (9,000) | - |
| 5862 | Independent Living - BASIC | 3,000 | 5,400 | (2,400) | - |
| 5864 | Foster Parent Respite Care | 3,500 | 3,500 | 0 | - |
| 5866 | Promoting Safe and Stable | 40,000 | 40,000 | 0 | - |
| 5872 | VIEW Purchase Service | 122,000 | 62,000 | 60,000 | 9,300 |
| 5873 | Foster Parent Training - Local | 15,300 | 15,300 | 0 | - |
| 5875 | CPR Trainings | 1,050 | 1,050 | 0 | - |
| 5890 | Quality Initiative Child Care | 11,000 | 11,000 | 0 | - |
| 5895-000 | Adult Protective Services | 8,967 | 8,967 | 0 | - |
| | TOTALS | 2,136,250 | 1,795,750 | 340,500 | 53,298 |



Dennis D. Linaburg
Fire Chief

MEMORANDUM

TO: Cheryl Shiffler, Director
Finance Department

FROM: Dennis D. Linaburg, Chief
Fire and Rescue Department 

SUBJECT: Request for Supplemental Appropriation

DATE: April 9, 2019

Our Department is respectfully requesting the following Supplemental Appropriation for Fund 30 – Expense Recovery – to cover revenue expected to be received in excess of FY19 budgeted revenue in order to distribute recovery funds to the volunteer stations and the County. No local funds are requested for Fund 30. We are requesting a total appropriation of **\$458,144.00**

Volunteer Fire & Rescue: 030-013300-5604-000-000 \$256,361.00
Frederick County Fire & Rescue: 030-013300-5604-000-001 \$201,783.00

If you have any questions or need additional information, please do not hesitate to contact me.

/attachment (1)

DDL:mhn
Cc: File

3-030-016010-0001

| DATE | DEPARTMENT/GENERAL FUND | REASON FOR TRANSFER | FROM | TO | ACCT | CODE | AMOUNT |
|-----------|------------------------------------|--|------|------|------|------|--------------|
| 3/6/2019 | INFORMATION TECHNOLOGY | IT SWITCH | 1220 | 8007 | 000 | 003 | 199,470.00 |
| | TRANSFER/CONTINGENCY | | 9301 | 5890 | 000 | 000 | (199,470.00) |
| 3/6/2019 | COUNTY ATTORNEY | SALARY ADJUSTMENT 3/1/19 | 1202 | 1001 | 000 | 003 | 2,597.00 |
| | COUNTY ATTORNEY | | 1202 | 2001 | 000 | 000 | 199.00 |
| | COUNTY ATTORNEY | | 1202 | 2002 | 000 | 000 | 255.00 |
| | COUNTY ATTORNEY | | 1202 | 2006 | 000 | 000 | 34.00 |
| | COUNTY ATTORNEY | | 1202 | 2008 | 000 | 000 | 16.00 |
| | COUNTY ATTORNEY | | 1202 | 2011 | 000 | 000 | 3.00 |
| | TRANSFERS/CONTINGENCY | | 9301 | 5890 | 000 | 000 | (3,104.00) |
| 3/8/2019 | INSPECTIONS | TO COVER DEFICIT FOR PRINTING | 3401 | 4003 | 000 | 002 | (1,000.00) |
| | INSPECTIONS | | 3401 | 3006 | 000 | 000 | 1,000.00 |
| 3/8/2019 | COUNTY OFFICE BUILDINGS/COURTHOUSE | WASHINGTON GAS BILL MILLWOOD FIRE STATION | 4304 | 5408 | 000 | 000 | (500.00) |
| | COUNTY OFFICE BUILDINGS/COURTHOUSE | | 4304 | 5102 | 000 | 000 | 500.00 |
| | COUNTY OFFICE BUILDINGS/COURTHOUSE | | 4304 | 5407 | 000 | 000 | (1,000.00) |
| | COUNTY OFFICE BUILDINGS/COURTHOUSE | | 4304 | 5102 | 000 | 000 | 1,000.00 |
| 3/12/2019 | COUNTY OFFICE BUILDINGS/COURTHOUSE | PUBLIC SAFETY WATER AND SEWER/PRICES DOUBLED 2019 | 4304 | 3004 | 000 | 006 | (1,500.00) |
| | COUNTY OFFICE BUILDINGS/COURTHOUSE | | 4304 | 5103 | 000 | 005 | 1,500.00 |
| 3/12/2012 | COUNTY OFFICE BUILDINGS/COURTHOUSE | REPAIR FURNACE 3 AND 4 MILLWOOD STATION | 4304 | 3004 | 000 | 022 | (500.00) |
| | COUNTY OFFICE BUILDINGS/COURTHOUSE | | 4304 | 3004 | 000 | 021 | 500.00 |
| 3/13/2013 | INFORMATION TECHNOLOGY | TO COVER NEW GIS TECH HIRE | 1220 | 1001 | 000 | 057 | (1,410.00) |
| | INFORMATION TECHNOLOGY | | 1220 | 1001 | 000 | 022 | 1,410.00 |
| 3/13/2013 | INFORMATION TECHNOLOGY | TO COVER PROMOTION TO GIS ANALYST | 1220 | 1001 | 000 | 021 | (6,064.70) |
| | INFORMATION TECHNOLOGY | | 1220 | 1001 | 000 | 024 | 6,064.70 |
| 3/13/2019 | INFORMATION TECHNOLOGY | REMAINING PURCHASE FOR PSB MIGRATION | 1220 | 3005 | 000 | 000 | (5,000.00) |
| | INFORMATION TECHNOLOGY | | 1220 | 3002 | 000 | 000 | 5,000.00 |
| | INFORMATION TECHNOLOGY | | 1220 | 5506 | 000 | 000 | (2,600.00) |
| | INFORMATION TECHNOLOGY | | 1220 | 3002 | 000 | 002 | 2,600.00 |
| 3/13/2019 | MANAGEMENT INFORMATION SYSTEM | TO COVER SHERIFF'S OFFICE REFRESH | 1222 | 3002 | 000 | 000 | (13,748.00) |
| | INFORMATION TECHNOLOGY | | 1222 | 5401 | 000 | 000 | 13,748.00 |
| 3/15/2019 | BOARD OF SUPERVISORS | COVER DEFICIT IN OTHER EXPENSES LINE ITEM | 1101 | 5506 | 000 | 000 | (700.00) |
| | OTHER | | 1224 | 5415 | 000 | 000 | 700.00 |
| 3/15/2019 | COUNTY OFFICE BUILDINGS/COURTHOUSE | TRANSFER FUNDS FOR CLEARBROOK PARKING LOT | 4304 | 5605 | 000 | 005 | (70,000.00) |
| | REFUSE COLLECTION | | 4203 | 8700 | 000 | 000 | (60,000.00) |
| | TRANSFERS/CONTINGENCY | | 9301 | 5807 | 000 | 001 | (25,000.00) |
| | OTHER | | 1224 | 3002 | 000 | 000 | (30,000.00) |
| | INFORMATION TECHNOLOGY | | 1220 | 5506 | 000 | 000 | (8,000.00) |
| | MANAGEMENT INFORMATION SYSTEMS | | 1222 | 5401 | 000 | 000 | (10,000.00) |
| | MANAGEMENT INFORMATION SYSTEMS | | 1222 | 3004 | 000 | 001 | (3,000.00) |
| | OTHER | | 1224 | 5415 | 000 | 002 | (29,000.00) |
| | CLEARBROOK PARK | | 7109 | 8900 | 000 | 000 | 235,000.00 |
| 3/20/2019 | COUNTY OFFICE BUILDINGS/COURTHOUSE | CLEAN UP FCMS FOLLOWING VANDALISM OF SCHOOL PROPERTY | 4304 | 3004 | 000 | 005 | (3,825.00) |
| | COUNTY OFFICE BUILDINGS/COURTHOUSE | | 4304 | 3004 | 000 | 010 | 3,825.00 |
| 3/20/2019 | LITTER CONTROL GRANT | PRINTING OF PICKUP DECALS | 4205 | 3004 | 000 | 002 | (200.00) |
| | LITTER CONTROL GRANT | | 4205 | 3006 | 000 | 000 | 200.00 |
| 3/20/2019 | CLERK OF THE CIRCUIT COURT | SALARY ADJUSTMENT | 2106 | 3006 | 000 | 000 | (110.05) |
| | CLERK OF THE CIRCUIT COURT | | 2106 | 1001 | 000 | 039 | 110.05 |
| | CLERK OF THE CIRCUIT COURT | | 2106 | 3006 | 000 | 000 | (243.49) |
| | CLERK OF THE CIRCUIT COURT | | 2106 | 1001 | 000 | 005 | 243.49 |
| | CLERK OF THE CIRCUIT COURT | | 2106 | 3006 | 000 | 000 | (147.50) |
| | CLERK OF THE CIRCUIT COURT | | 2106 | 1001 | 000 | 038 | 147.50 |
| | CLERK OF THE CIRCUIT COURT | | 2106 | 3006 | 000 | 000 | (345.20) |
| | CLERK OF THE CIRCUIT COURT | | 2106 | 1001 | 000 | 002 | 345.20 |
| | CLERK OF THE CIRCUIT COURT | | 2106 | 3006 | 000 | 000 | (189.70) |
| | CLERK OF THE CIRCUIT COURT | | 2106 | 1001 | 000 | 037 | 189.70 |
| | CLERK OF THE CIRCUIT COURT | | 2106 | 3006 | 000 | 000 | (594.82) |
| | CLERK OF THE CIRCUIT COURT | | 2106 | 1001 | 000 | 004 | 594.82 |
| | CLERK OF THE CIRCUIT COURT | | 2106 | 3006 | 000 | 000 | (288.39) |
| | CLERK OF THE CIRCUIT COURT | | 2106 | 1001 | 000 | 036 | 288.39 |
| | CLERK OF THE CIRCUIT COURT | | 2106 | 3006 | 000 | 000 | (833.07) |
| | CLERK OF THE CIRCUIT COURT | | 2106 | 1001 | 000 | 040 | 833.07 |
| 3/20/2019 | COUNTY OFFICE BUILDINGS/COURTHOUSE | SECURE TRAILERS AT FCMS AFTER VANDALISM OF SCHOOL | 4304 | 3004 | 000 | 005 | (113.25) |
| | COUNTY OFFICE BUILDINGS/COURTHOUSE | | 4304 | 5400 | 000 | 010 | 113.25 |
| 3/20/2019 | COUNTY OFFICE BUILDINGS/COURTHOUSE | PARKING LOT LEASE WITH WINCHESTER AIRPORT | 4304 | 5302 | 000 | 021 | (577.00) |
| | COUNTY OFFICE BUILDINGS/COURTHOUSE | | 4304 | 3010 | 000 | 021 | 577.00 |
| 3/21/2019 | CLEARBROOK PARK | CLEARBROOK VOLLEYBALL COURT SAND TRANSPORT | 7109 | 5412 | 000 | 000 | (7,000.00) |
| | CLEARBROOK PARK | | 7109 | 8900 | 000 | 000 | 7,000.00 |
| 3/21/2019 | COUNTY OFFICE BUILDINGS/COURTHOUSE | FCMS VANDALISM | 4304 | 3004 | 000 | 005 | (1,092.50) |
| | COUNTY OFFICE BUILDINGS/COURTHOUSE | | 4304 | 3004 | 000 | 010 | 1,092.50 |
| | COUNTY OFFICE BUILDINGS/COURTHOUSE | | 4304 | 3004 | 000 | 005 | (23.92) |
| | COUNTY OFFICE BUILDINGS/COURTHOUSE | | 4304 | 5400 | 000 | 010 | 23.92 |
| 3/22/2019 | COUNTY OFFICE BUILDINGS/COURTHOUSE | HEATING COUNTY ADMINISTRATION BUILDING | 4304 | 3004 | 000 | 005 | (1,486.66) |
| | COUNTY OFFICE BUILDINGS/COURTHOUSE | | 4304 | 5102 | 000 | 000 | 1,486.66 |
| 3/22/2019 | SHERIFF | TO COVER FEBRUARY EXPENSES | 3102 | 3004 | 000 | 002 | (197.00) |
| | SHERIFF | | 3102 | 5411 | 000 | 000 | 197.00 |
| 3/26/2019 | REFUSE COLLECTION | MOVE FUNDS TO SUPPLY LINE ITEM | 4203 | 8006 | 000 | 000 | (9,400.00) |
| | | | 4203 | 5413 | 000 | 000 | 9,400.00 |
| 3/26/2019 | MANAGEMENT INFORMATION SYSTEMS | TO COVER LEASE PAYMENTS FOR XEROX PRINTER | 1222 | 5401 | 000 | 000 | (3,800.00) |
| | MANAGEMENT INFORMATION SYSTEMS | | 1222 | 9001 | 000 | 000 | 3,800.00 |
| 3/27/2019 | RECREATION CENTERS AND PLAYGROUNDS | FOR SHADE STRUCTURES AT POOLS | 7104 | 3010 | 000 | 000 | (15,000.00) |

| | | | | | | | |
|-----------|------------------------------------|--------------------------------------|------|------|-----|-----|-------------|
| | CLEARBROOK PARK | | 7109 | 3004 | 000 | 003 | 15,000.00 |
| 3/27/2019 | INFORMATION TECHNOLOGY | BOARD ACTION 3/27/19 SHERIFF LAPTOPS | 1220 | 5401 | 000 | 004 | (95,475.00) |
| | SHERIFF | | 3102 | 9001 | 000 | 000 | 95,475.00 |
| 3/29/2019 | SHERIFF | MARCH PROMOTIONS | 3102 | 1001 | 000 | 073 | (1,622.73) |
| | SHERIFF | | 3102 | 1002 | 000 | 085 | 1,622.73 |
| | SHERIFF | | 3102 | 1001 | 000 | 012 | (2,233.05) |
| | SHERIFF | | 3102 | 1002 | 000 | 072 | 2,233.05 |
| | SHERIFF | | 3102 | 1002 | 000 | 032 | (2,063.26) |
| | SHERIFF | | 3102 | 1001 | 000 | 054 | 2,063.26 |
| | SHERIFF | | 3102 | 1001 | 000 | 076 | (4,211.53) |
| | SHERIFF | | 3102 | 1001 | 000 | 067 | 4,211.53 |
| | FIRE AND RESCUE | | 3505 | 1007 | 000 | 001 | (1,578.00) |
| | FIRE AND RESCUE | | 3505 | 1001 | 000 | 129 | 1,578.00 |
| 3/29/2019 | COUNTY OFFICE BUILDINGS/COURTHOUSE | REPLACE SECURITY CAMERAS | 4304 | 3004 | 000 | 003 | (1,330.09) |
| | COUNTY OFFICE BUILDINGS/COURTHOUSE | | 4304 | 8007 | 000 | 000 | 1,330.09 |
| 3/29/2019 | RECREATION CENTERS AND PLAYGROUNDS | SHADE STRUCTURES AT CLEARBROOK | 7104 | 3010 | 000 | 000 | (200.00) |
| | CLEARBROOK PARK | | 7109 | 3004 | 000 | 003 | 200.00 |

County of Frederick
General Fund
March 31, 2019

| ASSETS | FY19
<u>3/31/19</u> | FY18
<u>3/31/18</u> | Increase
<u>(Decrease)</u> |
|------------------------------------|------------------------|------------------------|----------------------------------|
| Cash and Cash Equivalents | 49,355,609.06 | 46,032,361.90 | 3,323,247.16 *A |
| Petty Cash | 1,555.00 | 1,555.00 | 0.00 |
| Receivables: | | | |
| Taxes, Commonwealth, Reimb. P/P | 3,103,428.90 | 2,935,603.14 | 167,825.76 |
| Streetlights | 535.91 | 746.71 | (210.80) |
| Miscellaneous Charges | 28,099.70 | 52,654.59 | (24,554.89) |
| Due from Fred. Co. San. Auth. | 657,083.23 | 657,083.23 | 0.00 |
| Prepaid Postage | 3,480.83 | 1,540.86 | 1,939.97 |
| GL controls (est.rev / est. exp) | <u>(5,216,625.97)</u> | <u>(14,320,941.50)</u> | <u>9,104,315.53</u> (1) Attached |
| TOTAL ASSETS | <u>47,933,166.66</u> | <u>35,360,603.93</u> | <u>12,572,562.73</u> |
| LIABILITIES | | | |
| Retainage Payable | 47,010.53 | 0.00 | 47,010.53 |
| Performance Bonds Payable | 827,832.45 | 1,308,138.79 | (480,306.34) |
| Taxes Collected in Advance | 254,886.18 | 561,569.46 | (306,683.28) *B |
| Deferred Revenue | <u>3,132,363.51</u> | <u>2,986,734.95</u> | <u>145,628.56</u> *C |
| TOTAL LIABILITIES | 4,262,092.67 | 4,856,443.20 | (594,350.53) |
| EQUITY | | | |
| Fund Balance | | | |
| Reserved: | | | |
| Encumbrance General Fund | 1,743,975.56 | 3,444,652.69 | (1,700,677.13) (2) Attached |
| Conservation Easement | 4,779.85 | 4,779.85 | 0.00 |
| Peg Grant | 331,565.38 | 234,066.38 | 97,499.00 |
| Prepaid Items | 949.63 | 949.63 | 0.00 |
| Advances | 657,083.23 | 657,083.23 | 0.00 |
| Employee Benefits | 93,120.82 | 93,120.82 | 0.00 |
| Courthouse Fees | 408,676.25 | 362,751.09 | 45,925.16 |
| Historical Markers | 17,804.23 | 17,542.19 | 262.04 |
| Reserve For Capital | 7,028,510.00 | 0.00 | 7,028,510.00 |
| Animal Shelter | 1,216,179.07 | 1,091,175.27 | 125,003.80 |
| Sheriff's Reserve | 1,000.00 | 1,000.00 | 0.00 |
| Proffers | 5,158,521.68 | 4,160,177.57 | 998,344.11 (3) Attached |
| Parks Reserve | 17,631.82 | 12,413.70 | 5,218.12 |
| E-Summons Funds | 163,429.73 | 78,269.19 | 85,160.54 |
| VDOT Revenue Sharing | 436,270.00 | 436,270.00 | 0.00 |
| Undesignated Adjusted Fund Balance | <u>26,441,576.74</u> | <u>19,909,909.12</u> | <u>6,531,667.62</u> (4) Attached |
| TOTAL EQUITY | <u>43,721,073.99</u> | <u>30,504,160.73</u> | <u>13,216,913.26</u> |
| TOTAL LIAB. & EQUITY | <u>47,983,166.66</u> | <u>35,360,603.93</u> | <u>12,622,562.73</u> |

NOTES:

*A Cash increase is a result of an increase in fund balance when impacted by budget controls.

*B Decrease in prepayment of real estate taxes at year end in the previous year to prepay because of the new tax law.

*C Deferred revenue includes taxes receivable, street lights, misc. charges, dog tags, and motor vehicle registration fees.

BALANCE SHEET

| (1) GL Controls | FY19 | FY18 | Inc/(Decrease) |
|---------------------|---------------|---------------|----------------|
| Est.Revenue | 180,339,207 | 171,298,698 | 9,040,509 |
| Appropriations | (80,324,107) | (84,308,250) | 3,984,143 |
| Est.Tr.to Other fds | (106,975,701) | (104,756,042) | (2,219,660) |
| Encumbrances | 1,743,976 | 3,444,653 | (1,700,677) |
| | (5,216,626) | (14,320,942) | 9,104,316 |

(2) General Fund Purchase Orders 3/19

| DEPARTMENT | Amount |
|-----------------------------|---|
| Commissioner of the Revenue | 28,822.13 2019 Chevrolet Colorado |
| Fire and Rescue | 26,015.00 Uniforms |
| | 47,300.00 Protective Clothing |
| | 10,235.23 Emergency Lighting for 2019 Ford F-250 includes Installation |
| | 34,439.32 Motorola Multi-Ban Radios and Accessories |
| | 31,578.70 2019 Ford F-150 4x4 |
| | 30,381.99 2019 Ford E-250 Cargo Van |
| | 16,290.71 Emergency Lighting, Push Bumper & Installation |
| | 63,730.07 LifePak & Lucas Annual Preventive Maintenance |
| | 3,489.00 A.R.E. Truck Cap&F-150 Bed Slide |
| | 6,453.36 Scott SCBA Masks |
| IT | 199,469.48 Cisco Catalyst Switching Platform for Public Safety Building |
| Maintenance Administration | 29,800.85 Ford F-150 Pickup 4x4 |
| MIS | 4,480.00 Tax Paper |
| Parks | 40,355.15 Outdoor Gym & Installation Sherando |
| | 10,606.10 Frederick Heights Park Trail |
| | 560.40 Agricultural Supplies |
| | 426,785.00 Sherando Park Recreation Access Project |
| | 6,933.75 Event Shirts |
| | 6,246.00 Trailer |
| | 1,532.40 Youth Basketball Uniforms |
| | 5,572.25 Spring/Summer Uniforms for Summer Events |
| | 858.00 Summer League Basketball Uniforms |
| | 104,372.00 Sherando Park Restroom Facility |
| | 751.91 Crafts Order |
| Planning | 6,200.00 HP Designjet Printer |
| Registrar | 223.60 Envelopes |
| Sheriff | 4,540.00 One Solution Software and Installation Service |
| | 254.59 Body Vest Carriers |
| | 887.65 Uniforms |
| | 110.40 Tactical Equipment |
| | 127,600.00 Armored Swat Van |
| | 9,000.00 (12) Simunition Guns |
| | 10,747.90 Uniforms |
| | 8,992.35 (15) Body Armor |
| | 5,276.64 Combat Uniforms |
| | 36,782.57 (12) 2019 Ford Truck Police Utility (1) Ford F-150 Responder |
| | 46,980.00 (2) 2019 Chevrolet Impalas |
| | 166,719.12 (24) Motorola APX8500 All Band Mobile Radios w/Accessories |
| | 148,823.64 (18) Light Bars and Accessories for 2019 Police Interceptors |
| | 23,986.00 (100) Batteries & Accessories for Motorola Portable Radios |
| | 5,356.00 (13) Flex 9Body Armor |
| Treasurer | 4,436.30 Envelopes |
| Total | 1,743,975.56 |

| (3)Proffer Information | SCHOOLS | PARKS | FIRE & RESCUE | Designated Other Projects | TOTAL |
|------------------------|--------------|-----------|---------------|---------------------------|--------------|
| Balance 3/31/19 | 2,751,622.38 | 87,651.67 | 463,712.91 | 1,855,534.72 | 5,158,521.68 |

Designated Other Projects Detail

| | |
|-------------------------------|---|
| Administration | 327,492.71 |
| Bridges | 14,714.00 |
| Historic Preservation | 158,000.00 12/11/14 Board Action designated \$50,000 for final debt payment |
| Library | 200,857.01 on the Huntsberry property. |
| Rt. 50 Trans.Imp. | 10,000.00 |
| Rt. 50 Rezoning | 25,000.00 |
| Rt. 656 & 657 Imp. | 25,000.00 |
| RT.277 | 162,375.00 |
| Sheriff | 81,706.00 |
| Solid Waste | 12,000.00 |
| Stop Lights | 52,445.00 |
| Treasurer | 700.00 |
| BPG Properties/Rt.11 Corridor | 330,000.00 |
| Blackburn Rezoning | 452,745.00 |
| Clearbrook Bus.Ctr.Rezoning | 2,500.00 |
| Total | 1,855,534.72 |

Other Proffers 3/19

| | |
|---------------------------|-----------------|
| (4) Fund Balance Adjusted | |
| Ending Balance 3/19 | 35,887,597.79 |
| Revenue 3/19 | 103,197,440.25 |
| Expenditures 3/19 | (57,824,138.44) |
| Transfers 3/19 | (54,819,322.86) |
| Ending Balance 3/19 | 26,441,576.74 |

County of Frederick
 Comparative Statement of Revenues, Expenditures
 and Changes in Fund Balance
 March 31, 2019

| REVENUES: | <u>Appropriated</u> | FY19
3/31/19
<u>Actual</u> | FY18
3/31/18
<u>Actual</u> | YTD
Actual
<u>Variance</u> |
|--|-----------------------|----------------------------------|----------------------------------|----------------------------------|
| General Property Taxes | 123,179,515.00 | 57,226,603.09 | 54,893,986.44 | 2,332,616.65 (1) |
| Other local taxes | 36,959,731.00 | 23,815,611.68 | 22,760,865.20 | 1,054,746.48 (2) |
| Permits & Privilege fees | 1,838,386.00 | 1,521,242.96 | 1,690,088.73 | (168,845.77) (3) |
| Revenue from use of money
and property | 538,093.55 | 1,137,981.14 | 574,168.34 | 563,812.80 (4) |
| Charges for Services | 3,090,299.00 | 2,181,902.82 | 2,011,077.93 | 170,824.89 |
| Miscellaneous | 586,230.71 | 459,142.52 | 464,742.23 | (5,599.71) |
| Recovered Costs | 1,650,574.00 | 1,508,357.31 | 1,141,346.45 | 367,010.86 (5) |
| Proffers | | 1,030,765.56 | 830,440.36 | 200,325.20 (5) |
| Intergovernmental: | | | | |
| Commonwealth | 12,491,877.74 | 14,189,368.32 | 13,929,192.89 | 260,175.43 (6) |
| Federal | 4,500.00 | 70,464.52 | 97,073.14 | (26,608.62) (7) |
| Insurance Recoveries | 0.00 | 3,104.33 | 0.00 | 3,104.33 |
| Transfers | 0.00 | 52,896.00 | 0.00 | 52,896.00 |
| TOTAL REVENUES | 180,339,207.00 | 103,197,440.25 | 98,392,981.71 | 4,804,458.54 |
| EXPENDITURES: | | | | |
| General Administration | 13,063,734.02 | 9,766,706.34 | 9,250,309.32 | 516,397.02 |
| Judicial Administration | 2,928,600.52 | 2,058,720.52 | 1,877,375.54 | 181,344.98 |
| Public Safety | 39,851,331.27 | 29,577,588.60 | 28,363,793.96 | 1,213,794.64 |
| Public Works | 6,219,995.63 | 3,837,297.54 | 3,615,014.09 | 222,283.45 |
| Health and Welfare | 10,223,475.00 | 6,330,110.83 | 6,202,279.58 | 127,831.25 |
| Education | 81,080.00 | 60,810.00 | 57,240.00 | 3,570.00 |
| Parks, Recreation, Culture | 8,932,116.30 | 5,044,072.20 | 4,785,491.89 | 258,580.31 |
| Community Development | 2,188,820.46 | 1,148,832.41 | 3,014,234.38 | (1,865,401.97) |
| TOTAL EXPENDITURES | 83,489,153.20 | 57,824,138.44 | 57,165,738.76 | 658,399.68 (8) |
| OTHER FINANCING SOURCES (USES): | | | | |
| Operating transfers from / to | 103,810,655.33 | 54,819,322.86 | 58,584,006.32 | (3,764,683.46) (9) |
| Excess (deficiency)of revenues & other
sources over expenditures
& other uses | (6,960,601.53) | (9,446,021.05) | (17,356,763.37) | (7,910,742.32) |
| Fund Balance per General Ledger | | 35,887,597.79 | 37,266,672.49 | (1,379,074.70) |
| Fund Balance Adjusted to reflect
Income Statement 3/31/19 | | 26,441,576.74 | 19,909,909.12 | 6,531,667.62 |

| (1)General Property Taxes | FY19 | FY18 | Increase/Decrease |
|--------------------------------------|------------|------------|-------------------|
| Real Estate Taxes | 29,954,705 | 28,521,994 | 1,432,712 |
| Public Services | 1,202,351 | 1,402,899 | (200,548) |
| Personal Property | 24,766,840 | 23,748,197 | 1,018,643 |
| Penalties and Interest | 986,994 | 947,293 | 39,701 |
| Credit Card Chgs./Delinq.Advertising | (26,986) | (62,083) | 35,097 |
| Adm.Fees For Liens&Distress | 342,698 | 335,686 | 7,012 |
| | 57,226,603 | 54,893,986 | 2,332,617 |

(2) Other Local Taxes

| | | | |
|-----------------------------|----------------------|----------------------|---------------------|
| Local Sales Tax | 8,369,448.90 | 8,045,490.44 | 323,958.46 |
| Communications Sales Tax | 680,117.72 | 738,153.07 | (58,035.35) |
| Utility Taxes | 2,467,871.06 | 2,369,476.78 | 98,394.28 |
| Business Licenses | 6,486,383.31 | 5,946,580.56 | 539,802.75 |
| Auto Rental Tax | 94,648.78 | 70,823.47 | 23,825.31 |
| Motor Vehicle Licenses Fees | 625,928.55 | 658,928.40 | (32,999.85) |
| Recordation Taxes | 1,333,749.96 | 1,247,897.18 | 85,852.78 |
| Meals Tax | 3,330,313.44 | 3,247,201.39 | 83,112.05 |
| Lodging Tax | 410,424.06 | 416,318.39 | (5,894.33) |
| Street Lights | 12,555.90 | 15,825.52 | (3,269.62) |
| Star Fort Fees | 4,170.00 | 4,170.00 | - |
| Total | 23,815,611.68 | 22,760,865.20 | 1,054,746.48 |

(3)Permits&Privileges

| | | | |
|-------------------------------|---------------------|---------------------|---------------------|
| Dog Licenses | 24,820.83 | 34,691.00 | (9,870.17) |
| Land Use Application Fees | 6,375.00 | 6,375.00 | - |
| Transfer Fees | 2,386.57 | 2,419.42 | (32.85) |
| Development Review Fees | 225,881.14 | 357,266.70 | (131,385.56) |
| Building Permits | 915,449.59 | 943,101.71 | (27,652.12) |
| 2% State Fees | 8,167.43 | 10,038.90 | (1,871.47) |
| Electrical Permits | 101,890.90 | 94,772.00 | 7,118.90 |
| Plumbing Permits | 22,339.50 | 17,501.00 | 4,838.50 |
| Mechanical Permits | 85,858.00 | 87,746.00 | (1,888.00) |
| Sign Permits | 1,925.00 | 5,675.00 | (3,750.00) |
| Permits Commerical Burning | 175.00 | 175.00 | - |
| Blasting Permits | 270.00 | 285.00 | (15.00) |
| Land Disturbance Permits | 122,504.00 | 129,342.00 | (6,838.00) |
| Septic Haulers Permit | 600.00 | - | 600.00 |
| Commercial Pump and Haul Fee | 500.00 | - | 500.00 |
| Residential Pump and Haul Fee | 100.00 | 500.00 | (400.00) |
| Transfer Development Rights | 2,000.00 | 200.00 | 1,800.00 |
| Total | 1,521,242.96 | 1,690,088.73 | (168,845.77) |

(4) Revenue from use of

| | | | |
|--------------|---------------------|-------------------|-------------------|
| Money | 1,106,949.97 | 541,026.94 | 565,923.03 |
| Property | 31,031.17 | 33,141.40 | (2,110.23) |
| Total | 1,137,981.14 | 574,168.34 | 563,812.80 |

| (5) Recovered Costs | FY19 | FY18 | Increase/Decrease |
|---|--------------|--------------|-------------------|
| | 3/31/2019 | 3/31/2018 | |
| Recovered Costs Treasurer's Office | 819.00 | 32,772.00 | (31,953.00) |
| Recovered Costs Social Services | 29,168.54 | 12,981.28 | 16,187.26 |
| Purchasing Card Rebate | 205,315.50 | 156,281.56 | 49,033.94 |
| Recovered Costs-IT/GIS | 27,261.00 | 27,261.00 | - |
| Recovered Costs F&R Fee Recovery | 342,395.54 | 158,627.30 | 183,768.24 |
| Recovered Cost Fire Companies | 171,346.53 | 94,182.34 | 77,164.19 |
| Recovered Costs Sheriff | 47,400.00 | 32,287.50 | 15,112.50 |
| Reimbursement Circuit Court | 7,106.00 | 8,232.51 | (1,126.51) |
| Reimb.Public Works/Planning Clean Up | 2,275.00 | 1,458.68 | 816.32 |
| Clarke County Container Fees | 52,725.22 | 39,785.70 | 12,939.52 |
| City of Winchester Container Fees | 32,963.06 | 31,374.08 | 1,588.98 |
| Refuse Disposal Fees | 91,483.79 | 74,204.10 | 17,279.69 |
| Recycling Revenue | 45,497.50 | 53,823.32 | (8,325.82) |
| Sheriff Restitution | 3,475.00 | - | 3,475.00 |
| Container Fees Bowman Library | 1,442.03 | 1,392.74 | 49.29 |
| Reimb.of Expenses Gen.District Court | 22,552.15 | 22,096.07 | 456.08 |
| Reimb.Task Force | 57,449.00 | 43,245.92 | 14,203.08 |
| Reimb. Elections | 4,548.42 | - | 4,548.42 |
| Westminster Canterbury Lieu of Tax | 18,651.80 | 18,651.80 | - |
| Grounds Maint. Frederick County Schools | 247,824.07 | 234,915.13 | 12,908.94 |
| Comcast PEG Grant | 65,843.50 | 65,163.00 | 680.50 |
| Fire School Programs | 11,680.00 | 12,578.01 | (898.01) |
| Clerks Reimbursement to County | 7,168.41 | 7,308.47 | (140.06) |
| Reimb. Sheriff | 11,966.25 | 12,723.94 | (757.69) |
| Subtotal Recovered Costs | 1,508,357.31 | 1,141,346.45 | 367,010.86 |
| Proffer Sovereign Village | 47,563.49 | - | 47,563.49 |
| Proffer Lynnhaven | - | 3,378.31 | (3,378.31) |
| Proffer Redbud Run | 90,356.00 | 58,086.00 | 32,270.00 |
| Proffer Canter Estates | - | 65,407.52 | (65,407.52) |
| Proffer Southern Hills | 148,372.58 | 157,120.00 | (8,747.42) |
| Proffer Snowden Bridge | 705,425.49 | 487,876.53 | 217,548.96 |
| Proffer Cedar Meadows | 39,048.00 | 58,572.00 | (19,524.00) |
| Subtotal Proffers | 1,030,765.56 | 830,440.36 | 200,325.20 |
| Grand Total | 2,539,122.87 | 1,971,786.81 | 567,336.06 |

| (6) Commonwealth Revenue | FY19 | FY18 | |
|------------------------------------|---------------|---------------|-------------------|
| | 3/31/2019 | 3/31/2018 | Increase/Decrease |
| Motor Vehicle Carriers Tax | 38,825.41 | 22,886.25 | 15,939.16 |
| Mobile Home Titling Tax | 66,870.71 | 90,343.99 | (23,473.28) |
| Recordation Taxes | 353,850.45 | 302,051.73 | 51,798.72 |
| P/P State Reimbursement | 6,526,528.18 | 6,526,528.18 | - |
| Shared Expenses Comm.Atty. | 367,560.81 | 368,245.29 | (684.48) |
| Shared Expenses Sheriff | 1,707,010.90 | 1,680,317.42 | 26,693.48 |
| Shared Expenses Comm.of Rev. | 151,027.24 | 148,093.96 | 2,933.28 |
| Shared Expenses Treasurer | 112,512.21 | 111,289.28 | 1,222.93 |
| Shared Expenses Clerk | 311,201.38 | 306,007.58 | 5,193.80 |
| Public Assistance Grants | 3,417,162.89 | 3,457,013.45 | (39,850.56) |
| Litter Control Grants | 18,330.00 | 14,774.00 | 3,556.00 |
| Four-For-Life-Funds | 88,718.24 | 85,262.32 | 3,455.92 |
| Emergency Services Fire Program | 260,328.00 | 251,441.00 | 8,887.00 |
| DMV Grant Funding | 21,553.61 | 20,295.28 | 1,258.33 |
| Parks -State Grants | 24,792.12 | - | 24,792.12 |
| State Grant Emergency Services | 6,520.00 | 15,925.00 | (9,405.00) |
| Parks State Grant | - | 10,985.00 | (10,985.00) |
| Sheriff State Grants | 37,015.50 | 36,827.60 | 187.90 |
| JJC Grant Juvenile Justice | 96,269.00 | 96,269.00 | - |
| Rent/Lease Payments | 159,863.68 | 202,524.77 | (42,661.09) |
| Spay/Neuter Assistance State | 2,558.72 | 2,167.50 | 391.22 |
| Wireless 911 Grant | 172,000.19 | 47,172.61 | 124,827.58 |
| State Forfeited Asset Funds | 17,068.18 | 18,725.14 | (1,656.96) |
| VA Dept. of Health | 93,033.80 | - | 93,033.80 |
| Victim Witness-Commonwealth Office | 138,767.10 | 113,919.04 | 24,848.06 |
| F&R OEMS Reimbursement | - | 127.50 | (127.50) |
| Total | 14,189,368.32 | 13,929,192.89 | 260,175.43 |

County of Frederick

General Fund

March 31, 2019

| (7) Federal Revenue | FY19 | FY18 | Increase/Decrease |
|----------------------------------|------------------|------------------|--------------------|
| Payments In Lieu of Taxes | 352.20 | 0.00 | 352.20 |
| Federal Forfeited Assets DOJ | - | 1,549.17 | (1,549.17) |
| Federal Funds Sheriff | 70,112.32 | 6,423.36 | 63,688.96 |
| Emergency Services Grant Federal | - | 87,278.14 | (87,278.14) |
| Forfeited Assets Treasury | - | 1,822.47 | (1,822.47) |
| Total | 70,464.52 | 97,073.14 | (26,608.62) |

(8) Expenditures

Expenditures increased \$658,399.68. **General Administration** increased \$516,397.02 and includes \$163,585.88 in IT for firewall support, switch and smartnet contract, and switch replacement core data network. **Public Safety** increased \$1,213,794.64 and reflects the year to date increase of \$786,477 in salaries and fringe benefits for Fire and Rescue. This increase was impacted by staff turnover, position reclassifications and additional positions. Inspections purchased (2) 2018 F-150 Ford 4x4 trucks at a cost of \$55,570.50, Fire and Rescue (3) 2019 F-250 trucks with emergency lighting equipment for \$110,653 and Isimulate training with IPADS and stethoscopes costing \$33,120. **Public Works** increased \$222,283.45 and includes an Engineering purchase for a 2018 Ford F-150 4x4 at cost of \$28,408, increased refuse disposal of \$56,142, and \$25,406 for a heat pump that includes installation and control system for \$32,400. **Community Development** decreased \$1,865,401.97, and was impacted by the \$2 million transfer to the Economic Development Authority for economic incentive for the Navy Credit Union in the previous year. The transfers decreased \$3,764,683.46. See chart below:

| (9) Transfers Decreased \$3,764,683.46 | FY19 | FY18 | Increase/Decrease |
|---|----------------------|----------------------|-----------------------|
| Transfer to School Operating | 41,730,199.45 | 40,951,338.87 | 778,860.58 |
| Transfer to Debt Service Schools | 7,267,910.00 | 7,986,237.50 | (718,327.50) |
| Transfer to Debt Service County | 1,747,270.88 | 2,213,272.39 | (466,001.51) |
| Transfer School Operating Capital | 4,067,416.47 | 3,088,287.00 | 979,129.47 |
| Operational Transfers | 6,526.06 | 21,250.56 | (14,724.50) |
| Board Contingency | 0.00 | 4,323,620.00 | (4,323,620.00) |
| Total | 54,819,322.86 | 58,584,006.32 | (3,764,683.46) |

*1 School Operating FY19 was \$542,862.45 C/F encumbrances and \$41,187,337 for half the School Operating. The FY18 total was C/F that includes School encumbrances of \$1,032,255.77, grant funds for \$285,003.55 received in FY17 for specific purposes, and \$997,264.55 represents unspent FY17 funds to be spent on buses. Additionally \$38,636,815 for half the School operating.

*2 The transfer to debt service was reduced \$718,327.50.

*3 Payments include the Bowman Library and the City of Winchester for Courtroom, Roof, and HVAC Projects, Millwood Station, Roundhill, Public Safety, and the Animal Shelter.

*4 School Operating Capital FY19 includes \$316,537.71 that represents a carry forward unspent, restricted grant funds and \$186,878.76 carry forward of unspent funds for the purchase of a school bus and security equipment. Additionally, \$1,264,000 for security equipment upgrade and \$2.3 million budgeted. FY18 budgeted for School Operating Capital.

*5 Timing of Insurance Charge Outs.

*6 Board of Supervisors Capital.

County of Frederick
 FUND 11 NORTHWESTERN REGIONAL ADULT DETENTION CENTER
 February 28, 2019

| ASSETS | FY2019
<u>3/31/19</u> | FY2018
<u>3/31/18</u> | Increase
<u>(Decrease)</u> |
|--|----------------------------|----------------------------|-------------------------------|
| Cash | 9,911,780.03 | 10,287,520.42 | (375,740.39) *1 |
| GL controls(est.rev/est.exp) | <u>(1,472,696.09)</u> | <u>(965,140.75)</u> | <u>(507,555.34)</u> |
| TOTAL ASSETS | <u>8,439,083.94</u> | <u>9,322,379.67</u> | <u>(883,295.73)</u> |
| | | | |
| LIABILITIES | | | |
| Accrued Operating Reserve Costs | <u>2,551,494.10</u> | <u>2,507,247.00</u> | <u>44,247.10</u> |
| TOTAL LIABILITIES | <u>2,551,494.10</u> | <u>2,507,247.00</u> | <u>44,247.10</u> |
| | | | |
| EQUITY | | | |
| Fund Balance Reserved | | | |
| Encumbrances Undesignated Fund Balance | 69,613.83 | 54,021.35 | 15,592.48 |
| | <u>5,817,976.01</u> | <u>6,761,111.32</u> | <u>(943,135.31) *2</u> |
| TOTAL EQUITY | <u>5,887,589.84</u> | <u>6,815,132.67</u> | <u>(927,542.83)</u> |
| TOTAL LIABILITY & EQUITY | <u>8,439,083.94</u> | <u>9,322,379.67</u> | <u>(883,295.73)</u> |

NOTES:

*1 Cash decreased \$375,740.39. Refer to the following page for comparative statement of revenues and expenditures and changes in fund balance.

*2 Fund balance decreased \$943,135.31. The beginning balance was \$5,566,043.76 and include: adjusting entries, budget controls for FY19(\$1,316,409.00) and the year to date revenue less expenditures of \$1,568,341.25.

| Current Unrecorded Accounts Receivable- | <u>FY19</u> |
|--|-------------------|
| Prisoner Billing: | 28,573.57 |
| Compensation Board Reimbursement 3/19 | <u>491,565.07</u> |
| Total | 520,138.64 |

County of Frederick
 Comparative Statement of Revenues, Expenditures
 and Changes in Fund Balance
 March 31, 2019

FUND 11 NORTHWESTERN REGIONAL ADULT DETENTION CENTER

| REVENUES: | <u>Appropriated</u> | FY2019
3/31/19
<u>Actual</u> | FY2018
3/31/18
<u>Actual</u> | YTD Actual
<u>Variance</u> |
|--|-----------------------|------------------------------------|------------------------------------|-------------------------------|
| Credit Card Probation | - | 416.50 | 99.76 | 316.74 |
| Interest | | 72,789.77 | 40,908.15 | 31,881.62 |
| Supervision Fees | 56,096.00 | 39,242.00 | 23,668.00 | 15,574.00 |
| Drug Testing Fees | 1,000.00 | 180.00 | 175.00 | 5.00 |
| Work Release Fees | 350,628.00 | 249,553.86 | 221,096.34 | 28,457.52 |
| Prisoner Fees from other localities | 0.00 | 237.96 | 158.64 | 79.32 |
| Federal Bureau Of Prisons | 0.00 | 165.00 | 220.00 | (55.00) |
| Local Contributions | 7,824,994.00 | 7,128,714.00 | 7,592,934.25 | (464,220.25) |
| Miscellaneous | 7,501.00 | 6,154.37 | 2,370.65 | 3,783.72 |
| Phone Commissions | 400,000.00 | 212,128.40 | 218,476.91 | (6,348.51) |
| Food & Staff Reimbursement | 80,000.00 | 44,099.94 | 52,240.50 | (8,140.56) |
| Elec.Monitoring Part.Fees | 97,000.00 | 94,662.23 | 51,581.03 | 43,081.20 |
| Share of Jail Cost Commonwealth | 1,350,000.00 | 621,220.97 | 635,672.60 | (14,451.63) |
| Reimb. Of Prior Year Deficit | | | 0.00 | |
| Medical & Health Reimb. | 85,000.00 | 36,055.67 | 49,844.94 | (13,789.27) |
| Shared Expenses CFW Jail | 5,400,000.00 | 3,646,620.79 | 3,527,806.11 | 118,814.68 |
| State Grants | 276,233.00 | 135,763.00 | 122,488.00 | 13,275.00 |
| D.J.C.P. Grant | 0.00 | 0.00 | 0.00 | 0.00 |
| Local Offender Probation | 277,467.00 | 138,777.00 | 141,717.00 | (2,940.00) |
| Bond Proceeds | 0.00 | 0.00 | 0.00 | 0.00 |
| Transfer From General Fund | 5,266,848.00 | 5,191,910.00 | 5,394,459.00 | (202,549.00) |
| TOTAL REVENUES | 21,472,767.00 | 17,618,691.46 | 18,075,916.88 | (457,225.42) |
| EXPENDITURES: | 23,015,076.92 | 16,050,350.21 | 14,918,439.33 | 1,131,910.88 |
| Excess(Deficiency)of revenues over expenditures | (1,542,309.92) | 1,568,341.25 | 3,157,477.55 | (1,589,136.30) |
| FUND BALANCE PER GENERAL LEDGER | | <u>4,249,634.76</u> | <u>3,603,633.77</u> | <u>646,000.99</u> |
| Fund Balance Adjusted To Reflect Income Statement 3/31/19 | | 5,817,976.01 | 6,761,111.32 | (943,135.31) |

County of Frederick
Fund 12 Landfill
March 31, 2019

| ASSETS | FY2019
3/31/19 | FY2018
3/31/18 | Increase
(Decrease) |
|-----------------------------------|----------------------|----------------------|------------------------|
| Cash | 37,417,545.87 | 37,646,168.62 | (228,622.75) |
| Receivables: | | | |
| Accounts Receivable | | | |
| Fees | 646,375.12 | 604,831.02 | 41,544.10 *1 |
| Accounts Receivable Other | 14,390.41 | 12,837.85 | 1,552.56 |
| Allow.Uncollectible Fees | (84,000.00) | (84,000.00) | 0.00 |
| Fixed Assets | 47,529,650.90 | 47,158,186.20 | 371,464.70 |
| Accumulated Depreciation | (31,283,925.70) | (29,232,078.83) | (2,051,846.87) |
| GL controls(est.rev/est.exp) | (4,119,578.55) | (3,228,789.45) | (890,789.10) |
| TOTAL ASSETS | 50,120,458.05 | 52,877,155.41 | (2,756,697.36) |
| LIABILITIES | | | |
| Accounts Payable | - | - | |
| Accrued VAC.Pay and Comp TimePay | 173,153.49 | 158,608.75 | 14,544.74 |
| Accrued Remediation Costs | 13,434,744.90 | 13,079,548.65 | 355,196.25 *2 |
| Deferred Revenue Misc.Charges | 14,390.41 | 12,837.85 | 1,552.56 |
| TOTAL LIABILITIES | 13,622,288.80 | 13,250,995.25 | 371,293.55 |
| EQUITY | | | |
| Fund Balance | | | |
| Reserved: | | | |
| Encumbrances | 0.00 | 29,368.55 | (29,368.55) *3 |
| Land Acquisition | 1,048,000.00 | 1,048,000.00 | 0.00 |
| New Development Costs | 3,812,000.00 | 3,812,000.00 | 0.00 |
| Environmental Project Costs | 1,948,442.00 | 1,948,442.00 | 0.00 |
| Equipment | 3,050,000.00 | 3,050,000.00 | 0.00 |
| Undesignated | | | |
| Fund Balance | 26,639,727.25 | 29,738,349.61 | (3,098,622.36) *4 |
| TOTAL EQUITY | 36,498,169.25 | 39,626,160.16 | (3,127,990.91) |
| TOTAL LIABILITY AND EQUITY | 50,120,458.05 | 52,877,155.41 | (2,756,697.36) |

NOTES:

*1 Landfill receivables increased \$41,544.10. Landfill fees at 3/19 were \$616,232.95 compared to \$556,722.65 at 3/18 for an increase of \$59,510.30. Delinquent fees at 3/19 were \$76,318.11 compared to \$45,047.60 at 3/18 for an increase of \$31,270.51.

*2 Remediation increased \$355,196.25 and includes \$308,263.00 for post closure and \$46,933.25 interest.

*3 There were no encumbrances at 3/31/19.

*4 Fund balance decreased \$3,098,622.36. The beginning balance was \$31,691,389.40 and includes adjusting entries, budget controls fro FY19(\$30,199), C/F Lndfill projects(\$3,706.000), and (\$1,315,463.15) for year to date revenue less expenses.

County of Frederick
 Comparative Statement of Revenue, Expenditures
 and Changes in Fund Balance
 March 31, 2019

| FUND 12 LANDFILL REVENUES | | FY2019
3/31/19 | FY2018
3/31/18 | YTD
Actual |
|---|----------------------|----------------------|----------------------|---------------------|
| | <u>Appropriated</u> | <u>Actual</u> | <u>Actual</u> | <u>Variance</u> |
| Credit Card Charges | 0.00 | 4,863.45 | 4,173.82 | 689.63 |
| Interest on Bank Deposits | 120,000.00 | 298,808.71 | 138,257.73 | 160,550.98 |
| Salvage and Surplus | 75,000.00 | 111,264.95 | 98,973.31 | 12,291.64 |
| Sanitary Landfill Fees | 6,562,000.00 | 5,097,581.05 | 4,318,793.48 | 778,787.57 |
| Charges to County | 0.00 | 436,936.80 | 380,794.53 | 56,142.27 |
| Charges to Winchester | 0.00 | 115,383.15 | 101,146.88 | 14,236.27 |
| Tire Recycling | 142,500.00 | 182,801.80 | 169,565.29 | 13,236.51 |
| Reg. Recycling Electronics | 91,200.00 | 45,365.00 | 39,852.16 | 5,512.84 |
| Greenhouse Gas Credit Sales | 0.00 | 29,680.82 | 4,918.95 | 24,761.87 |
| Miscellaneous | 0.00 | 8,839.00 | 4,755.00 | 4,084.00 |
| Renewable Energy Credits | 168,402.00 | 116,177.04 | 119,493.18 | (3,316.14) |
| Landfill Gas To Electricity | 312,837.00 | 216,835.56 | 285,557.79 | (68,722.23) |
| Insurance Recoveries | | 4,872.23 | 0.00 | 4,872.23 |
| Waste Oil Recycling | | 0.00 | 0.00 | 0.00 |
| TOTAL REVENUES | <u>7,471,939.00</u> | <u>6,669,409.56</u> | <u>5,666,282.12</u> | <u>1,003,127.44</u> |
| Operating Expenditures | 5,567,138.00 | 3,606,219.23 | 2,762,404.58 | 843,814.65 |
| Capital Expenditures | 6,024,379.55 | 4,378,653.48 | 483,610.38 | 3,895,043.10 |
| TOTAL Expenditures | <u>11,591,517.55</u> | <u>7,984,872.71</u> | <u>3,246,014.96</u> | <u>4,738,857.75</u> |
| Excess(deficiency)of revenue over expenditures | (4,119,578.55) | (1,315,463.15) | 2,420,267.16 | (3,735,730.31) |
| Fund Balance Per General Ledger | | <u>27,955,190.40</u> | <u>27,318,082.45</u> | <u>637,107.95</u> |
| FUND BALANCE ADJUSTED | | 26,639,727.25 | 29,738,349.61 | (3,098,622.36) |

County of Frederick, VA
Report on Unreserved Fund Balance
April 12, 2019

Unreserved Fund Balance, Beginning of Year, July 1, 2018 **46,153,037**

Prior Year Funding & Carryforward Amounts

| | |
|--|-------------|
| C/F forfeited asset funds | (52,569) |
| C/F Fire Company Capital | (224,818) |
| C/F Capital impact study | (59,067) |
| C/F Sheriff auto claim reimbursement | (15,191) |
| C/F Parks projects | (324,382) |
| C/F compactor rehab | (19,500) |
| C/F Middletown convenience site | (45,000) |
| C/F Stephenson convenience site | (385,342) |
| C/F spay/neuter program | (6,521) |
| C/F design/build animal shelter addition | (6,727) |
| C/F county admin bldg maintenance projects | (31,044) |
| C/F School Operating | (503,416) |
| | (1,673,577) |

Other Funding / Adjustments

| | |
|---|-------------|
| COR refund - Ascar Leasing | (2,521) |
| COR refund - BMW Financial | (2,790) |
| COR refund - Bowman Properties | (3,283) |
| COR refund - Capital Meats | (23,136) |
| Sheriff SWAT vehicle | (130,943) |
| COR refund - Acar Leasing | (3,026) |
| COR refund - Toyota Leasing | (4,087) |
| COR refund - Toyota Leasing | (3,714) |
| COR refund - Disabled Veteran | (3,492) |
| COR refund - Disabled Veteran | (3,907) |
| COR refund - Disabled Veteran | (7,297) |
| COR refund - American Telephone | (2,712) |
| COR refund - APC PCS LLC | (40,650) |
| Return unspent FY 18 VJCCCA funds | (41,450) |
| School Safety Phase II | (1,264,000) |
| COR refund - Enterprise FM | (5,786) |
| COR refund - Disabled Veteran | (2,543) |
| COR refund - Disabled Veteran | (3,501) |
| COR refund - Disabled Veteran | (12,290) |
| correct original budget appropriation error | 28,400 |
| COR refund - Handy Mart | (12,321) |
| COR refund - James Plummer | (2,876) |
| COR refund - Toyota Leasing | (3,025) |
| Reserve for capital | (7,028,510) |
| COR refund - Physiotherapy Associates | (2,869) |
| COR refund - Randy M Manning LLC | (5,311) |
| COR refund - Stanley Steemer | (4,223) |
| | (8,591,862) |

Fund Balance, April 12, 2019 **35,887,598**

C

HUMAN RESOURCES COMMITTEE REPORT to the BOARD OF SUPERVISORS
Friday, April 12, 2019
9:00 a.m.
107 NORTH KENT STREET, WINCHESTER, VIRGINIA

A Human Resources Committee meeting was held in the First Floor Conference Room at 107 North Kent Street on Friday, April 12, 2019 at 9:00 a.m.

ATTENDEES:

Committee Members Present: Blaine Dunn, Chairman; Don Butler; Robert (Bob) Wells; Don and Doug McCarthy

Staff present: Michael Marciano, Human Resources Director; DeLois Blevins, Human Resources Manager; Rod Williams, County Attorney; and Jay Tibbs, Deputy County Administrator.

Others present: None

ITEMS REQUIRING ACTION BY BOARD OF SUPERVISORS:

1. The Human Resources Department presented recommended changes to Frederick County Human Resources policy regarding **Dismissal** (Attachment A). The committee recommends approval.
2. The Human Resources Department presented recommended changes to Frederick County Human Resources policy regarding **Verification of Employment and References** (Attachment B). The committee recommends approval.

ITEMS FOR INFORMATIONAL PURPOSES ONLY

1. The Human Resources Committee will continue to address changes to the policy regarding **Unsafe Conditions** at its May 2019 meeting.
2. In the course of discussing Frederick County's Employee Recognition program, the Human Resources Committee agreed that a "Recognition Committee" be created to explore how we can best recognize our outstanding employees.

Respectfully submitted,

HUMAN RESOURCES COMMITTEE

Blaine Dunn, Chairman
Don Butler
Beth Lewin
Doug McCarthy
Dorrie Wells
Robert (Bob) Wells

By Michael J. Marciano
Michael Marciano, Director of Human Resources

ATTACHMENT A

11.8 Dismissal

A dismissal is the most serious form of discipline and must be approved by the Director of Human Resources prior to any meeting with the employee.

- a. The Department Head shall prepare a memorandum to the employee giving notice of intent to terminate that includes the items listed below with a copy presented to the Director of Human Resources.
 1. A statement of the reasons for dismissal.
 2. A statement of the employee's rights to request a pre-termination hearing with the Director of Human Resources within two (2) working days of notice of intent to terminate.
 3. A statement that the right to a pre-termination hearing does not take the place of the grievance process, articulated in Section XII (Grievance Policy and Procedure) of Frederick County's Policy Manual, that may be filed after the result of the hearing is issued.
- b. Should the employee request a pre-termination hearing, the following shall occur:
 1. While waiting for the pre-termination hearing to take place, the employee shall be placed on unpaid administrative leave.
 2. At such hearing, the Director of Human Resources must inform the employee of the reasons for the dismissal and provide the employee an opportunity to respond.
 3. Following the pre-termination hearing, the Director of Human Resources shall communicate the decision to the employee in writing.
- c. The Department Head shall prepare an Employee Action Form and send it to the Director of Human Resources with a copy of the memo and written pre-termination hearing decision, if such hearing was requested by the employee. The County Administrator shall be notified of dismissals.

ATTACHMENT B

14.8 Verification of Employment and References

The County of Frederick maintains a neutral reference policy. Requests for employment verification, salary history, employment references and personal information regarding current and former staff members should always be directed to the Human Resources Department. The Human Resources Department will verify only past or present employment, job title, salary, and dates of employment.

D



COUNTY OF FREDERICK

Roderick B. Williams
County Attorney

540/722-8383
Fax 540/667-0370
E-mail rwillia@fcva.us

MEMORANDUM

TO: Frederick County Board of Supervisors
CC: Kris Tierney, County Administrator
FROM: Roderick B. Williams, County Attorney
DATE: Tuesday, April 16, 2019
RE: Commissioner of Revenue Refund Requests

Attached, for the Board's review, are requests to authorize the Treasurer to credit the following entities:

1. D L Peterson Trust – \$16,438.37
2. J B Hunt Transport Inc – \$5,629.33
3. Ryder Truck Rental LT – \$5,266.20
4. Undisclosed Taxpayer – Disabled Veteran's Relief – \$2,595.79

Roderick B. Williams
County Attorney

Attachments



COUNTY OF FREDERICK

Roderick B. Williams
County Attorney

540/722-8383
Fax 540/667-0370
E-mail rwillia@fcva.us

MEMORANDUM

TO: Ellen E. Murphy, Commissioner of the Revenue
Frederick County Board of Supervisors

CC: Kris Tierney, County Administrator

FROM: Roderick B. Williams, County Attorney

DATE: April 15, 2019

RE: Refund – D L Peterson Trust

I am in receipt of the Commissioner's request, dated April 5, 2019, to authorize the Treasurer to refund D L Peterson Trust the amount of \$16,438.37, for exoneration of personal property taxes from 2014 through 2018 and vehicle license fees from 2014 through 2018. This refund resulted from normal proration of vehicle taxes where vehicles were either sold or moved from this locality.

The Commissioner verified that documentation and details for this refund meet all requirements. Pursuant to the provisions of Section 58.1-3981(A) of the Code of Virginia (1950, as amended), I hereby note my consent to the proposed action. The Board of Supervisors will also need to act on the request for approval of a supplemental appropriation, as indicated in the Commissioner's memorandum.

A handwritten signature in blue ink, appearing to be "R. Williams", is written over a horizontal line.

Roderick B. Williams
County Attorney

Attachment



Frederick County, Virginia

OFFICE OF

COMMISSIONER OF THE REVENUE

107 North Kent Street
Winchester VA 22601

P.O. Box 552
Winchester VA 22604-0552

emurphy@fcva.us

www.fcva.us/cor



ELLEN E. MURPHY
COMMISSIONER

Phone: 540-665-5681
Fax: 540-667-6487

April 5, 2019

TO: Rod Williams, County Attorney
Cheryl Shiffler, Finance Director
Frederick County Board of Supervisors
Kris Tierney, County Administrator

FROM: Ellen E. Murphy, Commissioner of the Revenue

QA for EM

RE: Exoneration – D L Peterson Trust

Please approve a refund of \$16,438.37 for exoneration of vehicle personal property taxes and vehicle license fees from 2014 through 2018 in the name of D L Peterson Trust. Vehicles were either sold or moved out during this period and are the result of normal proration.

To comply with the requirements for the Treasurer to issue this refund, Board action is required.

The Commissioner's staff has verified all required data, and the paperwork is in the care of the Commissioner of the Revenue.

Please also approve a supplemental appropriation for the Finance Director on this request.

Exoneration is \$16,438.37.

Date: 4/04/19

Cash Register: COUNTY OF FREDERICK

Time: 16:30:22

Cashier: [REDACTED] Total Transactions: 676
Customer Name: D L PETERSON TRUST Customer Transactions: 65

Options: 2=Edit 4=Delete 5=View

| Opt | Dept | Trans | Ticket No. | Tax Amount | Penalty/Int | Amount Paid |
|-----|--------|-------|-------------|------------|-------------|-------------|
| - | PP2014 | 1 | 00126340146 | \$97.30- | \$.00 | \$97.30- |
| - | PP2015 | 2 | 00128250079 | \$503.01- | \$.00 | \$503.01- |
| - | PP2015 | 3 | 00128250080 | \$503.01- | \$.00 | \$503.01- |
| - | PP2016 | 4 | 00131230055 | \$466.56- | \$.00 | \$466.56- |
| - | PP2016 | 5 | 00131230056 | \$466.56- | \$.00 | \$466.56- |
| - | PP2016 | 6 | 00131230231 | \$225.18- | \$.00 | \$225.18- |
| - | PP2016 | 7 | 00131230232 | \$675.54- | \$.00 | \$675.54- |
| - | PP2017 | 8 | 00135110043 | \$404.60- | \$.00 | \$404.60- |
| - | PP2017 | 9 | 00135110044 | \$404.59- | \$.00 | \$404.59- |
| - | PP2017 | 10 | 00135110154 | \$48.20- | \$.00 | \$48.20- |
| - | PP2017 | 11 | 00135110195 | \$501.80- | \$.00 | \$501.80- |
| - | PP2017 | 12 | 00135110196 | \$501.79- | \$.00 | \$501.79- |

Multiple Pages Total Paid : \$16,438.37
F3=Exit F14=Show Map# F15=Show Balance F18=Sort-Entered F21=CmdLine
F20=Attach

Date: 4/04/19

Cash Register: COUNTY OF FREDERICK

Time: 16:30:22

Cashier: [REDACTED] Total Transactions: 676
Customer Name: D L PETERSON TRUST Customer Transactions: 65

Options: 2=Edit 4=Delete 5=View

| Opt | Dept | Trans | Ticket No. | Tax Amount | Penalty/Int | Amount Paid |
|-----|--------|-------|-------------|------------|-------------|-------------|
| - | PP2018 | 13 | 00138930001 | \$16.00- | \$.00 | \$16.00- |
| - | PP2018 | 14 | 00138930002 | \$47.99- | \$.00 | \$47.99- |
| - | PP2018 | 15 | 00138930023 | \$211.41- | \$.00 | \$211.41- |
| - | PP2018 | 16 | 00138930024 | \$211.41- | \$.00 | \$211.41- |
| - | PP2018 | 17 | 00138930040 | \$134.66- | \$.00 | \$134.66- |
| - | PP2018 | 18 | 00138930041 | \$374.83- | \$.00 | \$374.83- |
| - | PP2018 | 19 | 00138930042 | \$374.83- | \$.00 | \$374.83- |
| - | PP2018 | 20 | 00138930053 | \$83.63- | \$.00 | \$83.63- |
| - | PP2018 | 21 | 00138930054 | \$250.90- | \$.00 | \$250.90- |
| - | PP2018 | 22 | 00138930077 | \$54.88- | \$.00 | \$54.88- |
| - | PP2018 | 23 | 00138930078 | \$329.26- | \$.00 | \$329.26- |
| - | PP2018 | 24 | 00138930114 | \$55.79- | \$.00 | \$55.79- |

Multiple Pages Total Paid : \$16,438.37
F3=Exit F14=Show Map# F15=Show Balance F18=Sort-Entered F21=CmdLine
F20=Attach

Date: 4/04/19

Cash Register: COUNTY OF FREDERICK

Time: 16:30:22

Cashier: [REDACTED] Total Transactions: 676
Customer Name: D L PETERSON TRUST Customer Transactions: 65

Options: 2=Edit 4=Delete 5=View

| Opt | Dept | Trans | Ticket No. | Tax Amount | Penalty/Int | Amount Paid |
|-----|--------|-------|-------------|------------|-------------|-------------|
| - | PP2018 | 25 | 00138930122 | \$73.51- | \$.00 | \$73.51- |
| - | PP2018 | 26 | 00138930125 | \$123.33- | \$.00 | \$123.33- |
| - | PP2018 | 27 | 00138930126 | \$123.32- | \$.00 | \$123.32- |
| - | PP2018 | 28 | 00138930132 | \$173.14- | \$.00 | \$173.14- |
| - | PP2018 | 29 | 00138930133 | \$114.92- | \$.00 | \$114.92- |
| - | PP2018 | 30 | 00138930134 | \$137.90- | \$.00 | \$137.90- |
| - | PP2018 | 31 | 00138930135 | \$114.92- | \$.00 | \$114.92- |
| - | PP2018 | 32 | 00138930136 | \$137.90- | \$.00 | \$137.90- |
| - | PP2018 | 33 | 00138930137 | \$94.59- | \$.00 | \$94.59- |
| - | PP2018 | 34 | 00138930138 | \$567.52- | \$.00 | \$567.52- |
| - | PP2018 | 35 | 00138930151 | \$427.08- | \$.00 | \$427.08- |
| - | PP2018 | 36 | 00138930152 | \$427.07- | \$.00 | \$427.07- |

Multiple Pages Total Paid : \$16,438.37
F3=Exit F14=Show Map# F15=Show Balance F18=Sort-Entered F21=CmdLine
F20=Attach

* Needs Board Approval

Date: 4/04/19

Cash Register: COUNTY OF FREDERICK

Time: 16:30:22

Cashier: [REDACTED]
Customer Name: D L PETERSON TRUST

Total Transactions: 676
Customer Transactions: 65

Options: 2=Edit 4=Delete 5=View

| Opt | Dept | Trans | Ticket No. | Tax Amount | Penalty/Int | Amount Paid |
|-----|--------|-------|-------------|------------|-------------|-------------|
| - | PP2018 | 37 | 00138930175 | \$330.08- | \$.00 | \$330.08- |
| - | PP2018 | 38 | 00138930176 | \$396.09- | \$.00 | \$396.09- |
| - | PP2018 | 39 | 00138930177 | \$330.08- | \$.00 | \$330.08- |
| - | PP2018 | 40 | 00138930178 | \$396.09- | \$.00 | \$396.09- |
| - | PP2018 | 41 | 00138930179 | \$330.08- | \$.00 | \$330.08- |
| - | PP2018 | 42 | 00138930180 | \$396.09- | \$.00 | \$396.09- |
| - | PP2018 | 43 | 00138930181 | \$330.08- | \$.00 | \$330.08- |
| - | PP2018 | 44 | 00138930182 | \$396.09- | \$.00 | \$396.09- |
| - | PP2018 | 45 | 00138930183 | \$330.08- | \$.00 | \$330.08- |
| - | PP2018 | 46 | 00138930184 | \$396.09- | \$.00 | \$396.09- |
| - | PP2018 | 47 | 00138930212 | \$495.23- | \$.00 | \$495.23- |
| - | PP2018 | 48 | 00138930230 | \$371.43- | \$.00 | \$371.43- |

Multiple Pages
F3=Exit F14=Show Map#

Total Paid :
F15=Show Balance

\$16,438.37
F18=Sort-Entered

F21=CmdLine
F20=Attach

Date: 4/04/19

Cash Register: COUNTY OF FREDERICK

Time: 16:30:22

Cashier: [REDACTED]
Customer Name: D L PETERSON TRUST

Total Transactions: 676
Customer Transactions: 65

Options: 2=Edit 4=Delete 5=View

| Opt | Dept | Trans | Ticket No. | Tax Amount | Penalty/Int | Amount Paid |
|-----|--------|-------|-------------|------------|-------------|-------------|
| - | PP2018 | 49 | 00138930257 | \$136.69- | \$.00 | \$136.69- |
| - | PP2018 | 50 | 00138930258 | \$273.37- | \$.00 | \$273.37- |
| - | PP2018 | 51 | 00138930272 | \$399.73- | \$.00 | \$399.73- |
| - | PP2018 | 52 | 00138930280 | \$449.55- | \$.00 | \$449.55- |
| - | PP2018 | 53 | 00138930309 | \$96.94- | \$.00 | \$96.94- |
| - | PP2018 | 54 | 00138930310 | \$581.62- | \$.00 | \$581.62- |
| - | PP2018 | 55 | 00703300035 | \$294.03- | \$.00 | \$294.03- |
| - | VL2015 | 56 | 00179100001 | \$25.00- | \$.00 | \$25.00- |
| - | VL2016 | 57 | 00183730001 | \$25.00- | \$.00 | \$25.00- |
| - | VL2017 | 58 | 00190220001 | \$25.00- | \$.00 | \$25.00- |
| - | VL2017 | 59 | 00190420001 | \$25.00- | \$.00 | \$25.00- |
| - | VL2017 | 60 | 00191180001 | \$25.00- | \$.00 | \$25.00- |

Multiple Pages
F3=Exit F14=Show Map#

Total Paid :
F15=Show Balance

\$16,438.37
F18=Sort-Entered

F21=CmdLine
F20=Attach

Date: 4/04/19

Cash Register: COUNTY OF FREDERICK

Time: 16:30:22

Cashier: [REDACTED]
Customer Name: D L PETERSON TRUST

Total Transactions: 676
Customer Transactions: 65

Options: 2=Edit 4=Delete 5=View

| Opt | Dept | Trans | Ticket No. | Tax Amount | Penalty/Int | Amount Paid |
|-----|--------|-------|-------------|------------|-------------|-------------|
| - | VL2018 | 61 | 01231130001 | \$25.00- | \$.00 | \$25.00- |
| - | VL2018 | 62 | 01231230001 | \$25.00- | \$.00 | \$25.00- |
| - | VL2018 | 63 | 01231320001 | \$25.00- | \$.00 | \$25.00- |
| - | VL2018 | 64 | 01231740001 | \$25.00- | \$.00 | \$25.00- |
| - | VL2018 | 65 | 01231870001 | \$25.00- | \$.00 | \$25.00- |

Multiple Pages
F3=Exit F14=Show Map#

Total Paid :
F15=Show Balance

\$16,438.37
F18=Sort-Entered

F21=CmdLine
F20=Attach



COUNTY OF FREDERICK

Roderick B. Williams
County Attorney

540/722-8383
Fax 540/667-0370
E-mail rwillia@fcva.us

MEMORANDUM

TO: Ellen E. Murphy, Commissioner of the Revenue
Frederick County Board of Supervisors

CC: Kris Tierney, County Administrator

FROM: Roderick B. Williams, County Attorney

DATE: April 15, 2019

RE: Refund –J B Hunt Transport Inc

I am in receipt of the Commissioner's request, dated April 5, 2019, to authorize the Treasurer to refund J B Hunt Transport Inc. the amount of \$5,629.33, for exoneration of personal property taxes from 2016 through 2018 and vehicle license fees from 2016 through 2018. This refund resulted from normal proration of vehicle taxes where vehicles were either sold or moved from this locality.

The Commissioner verified that documentation and details for this refund meet all requirements. Pursuant to the provisions of Section 58.1-3981(A) of the Code of Virginia (1950, as amended), I hereby note my consent to the proposed action. The Board of Supervisors will also need to act on the request for approval of a supplemental appropriation, as indicated in the Commissioner's memorandum.

A handwritten signature in blue ink, appearing to be "R. Williams", is written over a horizontal line.

Roderick B. Williams
County Attorney

Attachment



Frederick County, Virginia

OFFICE OF

COMMISSIONER OF THE REVENUE

107 North Kent Street
Winchester VA 22601

P.O. Box 552
Winchester VA 22604-0552

emurphy@fcva.us

www.fcva.us/cor



ELLEN E. MURPHY
COMMISSIONER

Phone: 540-665-5681
Fax: 540-667-6487

April 5, 2019

TO: Rod Williams, County Attorney
Cheryl Shiffler, Finance Director
Frederick County Board of Supervisors
Kris Tierney, County Administrator

FROM: Ellen E. Murphy, Commissioner of the Revenue *JA
to EM*

RE: Exoneration – J B Hunt Transport Inc

Please approve a refund of \$5,629.33 for exoneration of vehicle personal property taxes and vehicle license fees from 2016 through 2018 in the name of J B Hunt Transport Inc. Vehicles were either sold or moved out during this period and are the result of normal proration.

To comply with the requirements for the Treasurer to issue this refund, Board action is required.

The Commissioner's staff has verified all required data, and the paperwork is in the care of the Commissioner of the Revenue.

Please also approve a supplemental appropriation for the Finance Director on this request.

Exoneration is \$5,629.33.

Date: 4/04/19

Cash Register: COUNTY OF FREDERICK

Time: 16:39:09

Cashier: [REDACTED]
Customer Name: J B HUNT TRANSPORT INC

Total Transactions: 676
Customer Transactions: 28

Options: 2=Edit 4=Delete 5=View

| Opt | Dept | Trans | Ticket No. | Tax Amount | Penalty/Int | Amount Paid |
|-----|--------|-------|-------------|------------|-------------|-------------|
| - | PP2016 | 1 | 00277120003 | \$154.31- | \$19.67- | \$173.98- |
| - | PP2016 | 2 | 00277120004 | \$154.30- | \$0.00 | \$154.30- |
| - | PP2017 | 3 | 00285010001 | \$139.12- | \$0.00 | \$139.12- |
| - | PP2017 | 4 | 00285010002 | \$139.12- | \$0.00 | \$139.12- |
| - | PP2017 | 5 | 00285010019 | \$291.60- | \$0.00 | \$291.60- |
| - | PP2017 | 6 | 00285010020 | \$291.60- | \$0.00 | \$291.60- |
| - | PP2017 | 7 | 00285010021 | \$340.20- | \$0.00 | \$340.20- |
| - | PP2017 | 8 | 00285010022 | \$340.20- | \$0.00 | \$340.20- |
| - | PP2017 | 9 | 00285010023 | \$437.04- | \$0.00 | \$437.04- |
| - | PP2017 | 10 | 00285010024 | \$437.03- | \$0.00 | \$437.03- |
| - | PP2018 | 11 | 00294230001 | \$125.15- | \$0.00 | \$125.15- |
| - | PP2018 | 12 | 00294230002 | \$125.14- | \$0.00 | \$125.14- |

Multiple Pages
F3=Exit F14=Show Map#

Total Paid :
F15=Show Balance

\$5,629.33
F18=Sort-Entered

F21=CmdLine
F20=Attach

Date: 4/04/19

Cash Register: COUNTY OF FREDERICK

Time: 16:39:09

Cashier: [REDACTED]
Customer Name: J B HUNT TRANSPORT INC

Total Transactions: 676
Customer Transactions: 28

Options: 2=Edit 4=Delete 5=View

| Opt | Dept | Trans | Ticket No. | Tax Amount | Penalty/Int | Amount Paid |
|-----|--------|-------|-------------|------------|-------------|-------------|
| - | PP2018 | 13 | 00294230004 | \$117.73- | \$0.00 | \$117.73- |
| - | PP2018 | 14 | 00294230019 | \$262.44- | \$0.00 | \$262.44- |
| - | PP2018 | 15 | 00294230020 | \$262.44- | \$0.00 | \$262.44- |
| - | PP2018 | 16 | 00294230021 | \$306.18- | \$0.00 | \$306.18- |
| - | PP2018 | 17 | 00294230022 | \$306.18- | \$0.00 | \$306.18- |
| - | PP2018 | 18 | 00294230023 | \$393.30- | \$0.00 | \$393.30- |
| - | PP2018 | 19 | 00294230024 | \$393.29- | \$0.00 | \$393.29- |
| - | PP2018 | 20 | 00294230026 | \$393.29- | \$0.00 | \$393.29- |
| - | VL2017 | 21 | 00400050001 | \$25.00- | \$0.00 | \$25.00- |
| - | VL2017 | 22 | 00400140001 | \$25.00- | \$0.00 | \$25.00- |
| - | VL2017 | 23 | 00400150001 | \$25.00- | \$0.00 | \$25.00- |
| - | VL2017 | 24 | 00400160001 | \$25.00- | \$0.00 | \$25.00- |

Multiple Pages
F3=Exit F14=Show Map#

Total Paid :
F15=Show Balance

\$5,629.33
F18=Sort-Entered

F21=CmdLine
F20=Attach

Date: 4/04/19

Cash Register: COUNTY OF FREDERICK

Time: 16:39:09

Cashier: [REDACTED]
Customer Name: J B HUNT TRANSPORT INC

Total Transactions: 676
Customer Transactions: 28

Options: 2=Edit 4=Delete 5=View

| Opt | Dept | Trans | Ticket No. | Tax Amount | Penalty/Int | Amount Paid |
|-----|--------|-------|-------------|------------|-------------|-------------|
| - | VL2018 | 25 | 01449250001 | \$25.00- | \$0.00 | \$25.00- |
| - | VL2018 | 26 | 01449340001 | \$25.00- | \$0.00 | \$25.00- |
| - | VL2018 | 27 | 01449350001 | \$25.00- | \$0.00 | \$25.00- |
| - | VL2018 | 28 | 01449360001 | \$25.00- | \$0.00 | \$25.00- |

Multiple Pages
F3=Exit F14=Show Map#

Total Paid :
F15=Show Balance

\$5,629.33
F18=Sort-Entered

F21=CmdLine
F20=Attach

* Needs Board Approval



COUNTY OF FREDERICK

Roderick B. Williams
County Attorney

540/722-8383
Fax 540/667-0370
E-mail rwillia@fcva.us

MEMORANDUM

TO: Ellen E. Murphy, Commissioner of the Revenue
Frederick County Board of Supervisors

CC: Kris Tierney, County Administrator

FROM: Roderick B. Williams, County Attorney

DATE: April 16, 2019

RE: Refund – Ryder Truck Rental LT

I am in receipt of the Commissioner's request, dated April 15, 2019, to authorize the Treasurer to refund Ryder Truck Rental LT the amount of \$5,266.20, for exoneration of personal property taxes for 2018. This refund resulted from normal proration of vehicle taxes where vehicles were either sold or moved from this locality.

The Commissioner verified that documentation and details for this refund meet all requirements. Pursuant to the provisions of Section 58.1-3981(A) of the Code of Virginia (1950, as amended), I hereby note my consent to the proposed action. The Board of Supervisors will also need to act on the request for approval of a supplemental appropriation, as indicated in the Commissioner's memorandum.

A handwritten signature in blue ink, appearing to be "R. Williams", is written over a horizontal line.

Roderick B. Williams
County Attorney

Attachment



Frederick County, Virginia

OFFICE OF

COMMISSIONER OF THE REVENUE

107 North Kent Street
Winchester VA 22601

P.O. Box 552
Winchester VA 22604-0552

emurphy@fcva.us

www.fcva.us/cor



ELLEN E. MURPHY
COMMISSIONER

Phone: 540-665-5681
Fax: 540-667-6487

April 15, 2019

TO: Rod Williams, County Attorney
Cheryl Shiffler, Finance Director
Frederick County Board of Supervisors
Kris Tierney, County Administrator

FROM: Ellen E. Murphy, Commissioner of the Revenue

RE: Exoneration – Ryder Truck Rental LT

*Jane Anderson
Dep COR*

Please approve a refund of \$5,266.20 for exoneration of vehicle personal property taxes for 2018 in the name of Ryder Truck Rental LT. Vehicles were either sold or moved out during this period and are the result of normal proration.

To comply with the requirements for the Treasurer to issue this refund, Board action is required.

The Commissioner's staff has verified all required data, and the paperwork is in the care of the Commissioner of the Revenue.

Please also approve a supplemental appropriation for the Finance Director on this request.

Exoneration is \$5,266.20.

Date: 4/09/19

Cash Register: COUNTY OF FREDERICK

Time: 14:57:17

Cashier: XXXXXXXXXX Total Transactions:
 Customer Name: RYDER TRUCK RENTAL LT Customer Transactions: 8

Options: 2=Edit 4=Delete 5=View

| Opt | Dept | Trans | Ticket No. | Tax Amount | Penalty/Int | Amount Paid |
|-----|--------|-------|-------------|-------------|-------------|-------------|
| - | PP2018 | 1 | 00528410010 | \$319.30- | \$0.00 | \$319.30- |
| - | PP2018 | 2 | 00528410014 | \$299.26- | \$0.00 | \$299.26- |
| - | PP2018 | 3 | 00528410022 | \$220.05- | \$0.00 | \$220.05- |
| - | PP2018 | 4 | 00528410025 | \$1,422.65- | \$0.00 | \$1,422.65- |
| - | PP2018 | 5 | 00528410026 | \$1,422.64- | \$0.00 | \$1,422.64- |
| - | PP2018 | 6 | 00528410029 | \$691.63- | \$0.00 | \$691.63- |
| - | PP2018 | 7 | 00528410030 | \$691.62- | \$0.00 | \$691.62- |
| - | PP2018 | 8 | 00528420006 | \$199.05- | \$0.00 | \$199.05- |

F3=Exit F14=Show Map# Total Paid : \$5,266.20 F15=Show Balance F18=Sort-Entered F21=CmdLine
 F20=Attach

** Needs Board Approval*



COUNTY OF FREDERICK

Roderick B. Williams
County Attorney

540/722-8383
Fax 540/667-0370
E-mail rwillia@fcva.us

MEMORANDUM

TO: Ellen E. Murphy, Commissioner of the Revenue
Frederick County Board of Supervisors

CC: Kris Tierney, County Administrator

FROM: Roderick B. Williams, County Attorney

DATE: April 15, 2019

RE: Refund – Undisclosed Taxpayer – Disabled Veteran’s Relief

I am in receipt of the Commissioner’s request, dated April 5, 2019, to authorize the Treasurer to refund a taxpayer the amount of \$2,595.79 from 2013 through 2018 for real estate taxes, based on proper filing of proof of 100% permanent and total disability directly due to military service, as required under the Virginia Code change as a result of the Constitutional amendment that took effect for 2011. Taxpayer’s name cannot be made public because of applicable legal requirements as to privacy, but is known to the Commissioner and the Treasurer on a confidential basis.

Pursuant to the provisions of Section 58.1-3981(A) of the Code of Virginia (1950, as amended), I hereby note my consent to the proposed action. The Board of Supervisors will also need to act on the request for approval of a supplemental appropriation, as indicated in the Commissioner’s memorandum.

A handwritten signature in blue ink, appearing to be "R. Williams", is written over a horizontal line.

Roderick B. Williams
County Attorney

Attachment



Frederick County, Virginia

OFFICE OF

COMMISSIONER OF THE REVENUE

107 North Kent Street
Winchester VA 22601

P.O. Box 552
Winchester VA 22604-0552

emurphy@fcva.us

www.fcva.us/cor



ELLEN E. MURPHY
COMMISSIONER

Phone: 540-665-5681
Fax: 540-667-6487

April 5, 2019

TO: Rod Williams, County Attorney
Cheryl Shiffler, Finance Director
Frederick County Board of Supervisors
Kris Tierney, County Administrator

FROM: Ellen E. Murphy, Commissioner of the Revenue

QA for EM

RE: Exoneration (Name withheld – Veteran’s Exemption – CONFIDENTIAL)

Please approve a refund of \$2,595.79 for exoneration of real estate taxes from 2013 through 2018 for a 100% permanently and totally service-connected disabled veteran. This refund applies to his principle residence and is supported by the Veterans Administration official documentation that has been provided to us.

To comply with the requirements for the Treasurer to issue this refund, Board action is required.

The Commissioner’s staff has verified all required data, and the paperwork is in the care of the Commissioner of the Revenue.

Please also approve a supplemental appropriation for the Finance Director on this request.

Exoneration is \$2,595.79.

Date: 4/04/19

Cash Register: COUNTY OF FREDERICK

Time: 16:42:39

Cashier:
Customer:

Total Transactions: 676
Customer Transactions: 11

Options: 2=Edit 4=Delete 5=View

| Opt | Dept | Trans | Ticket No. | Tax Amount | Penalty/Int | Amount Paid |
|-----|--------|-------|-------------|------------|-------------|-------------|
| - | RE2013 | 1 | 00227510002 | \$203.40- | \$.00 | \$203.40- |
| - | RE2014 | 2 | 00228560001 | \$203.41- | \$.00 | \$203.41- |
| - | RE2014 | 3 | 00228560002 | \$203.40- | \$.00 | \$203.40- |
| - | RE2015 | 4 | 00228990001 | \$207.88- | \$.00 | \$207.88- |
| - | RE2015 | 5 | 00228990002 | \$207.87- | \$.00 | \$207.87- |
| - | RE2016 | 6 | 00225230001 | \$222.73- | \$.00 | \$222.73- |
| - | RE2016 | 7 | 00225230002 | \$222.72- | \$.00 | \$222.72- |
| - | RE2017 | 8 | 00226500001 | \$278.77- | \$.00 | \$278.77- |
| - | RE2017 | 9 | 00226500002 | \$278.77- | \$.00 | \$278.77- |
| - | RE2018 | 10 | 00226380001 | \$283.42- | \$.00 | \$283.42- |
| - | RE2018 | 11 | 00226380002 | \$283.42- | \$.00 | \$283.42- |

Total Paid : \$2,595.79

F3=Exit F14=Show Map#

F15=Show Balance

F18=Sort-Entered

F21=CmdLine
F20=Attach

* Needs Board Approval

E



COUNTY of FREDERICK

Kris C. Tierney
County Administrator

540/665-6382

Fax: 540/667-0370

E-mail: ktierney@fcva.us

MEMORANDUM

TO: Board of Supervisors
FROM: Kris C. Tierney, County Administrator *KCT*
DATE: April 17, 2019
RE: Committee Appointments

Listed below are the vacancies/appointments due through May 2019. As a reminder, in order for everyone to have ample time to review applications, and so they can be included in the agenda, please remember to submit applications prior to Friday agenda preparation. Your assistance is greatly appreciated.

VACANCIES/OTHER

Handley Regional Library Board

Brian J. Hester
165 Babbs Run Lane
Winchester, VA 22603
Term Expires: 11/30/19
Four-year term

(Staff has been advised that Mr. Hester has resigned.) (The County has 5 seats on the Handley Regional Library Board as a result of the Joint Agreement and Memorandum of Understanding with the City. As stated in the library by-laws, members may only serve two terms.)

Extension Leadership Council

Margaret B. Douglas – Back Creek District Representative
452 Barley Lane
Winchester, VA 22602
Term Expires: 01/14/20
Four-year term

(See Attached Application of Brandon H. Monk) (The Extension Leadership Council is comprised of ten members, one member from each magisterial district appointed by the Board of Supervisors and four members-at large recommended by the Virginia Tech Extension Service. Members serve a four-year term.)

Board of Equalization

Luther O. Stiles
114 Lane Street
Stephens City, VA 22655
Home: (540)869-2504
Term: 01/01/17 - 12/31/19
Three-year term

Mr. Stiles has notified staff he does not wish to be reappointed when his term expires December 31, 2019. (See Attached Correspondence)

(Reminder there is a current vacancy. Staff and Board of Supervisors will continue to seek applicants for seat(s) on the Board of Equalization.) *(The Board of Equalization is composed of five members. Members must be free holders in the county. In October 2010, the Board of Supervisors appointed the Board of Equalization as a "permanent" board for subsequent reassessments. The original five members were appointed for the following terms: one member for a one-year term; one member for a two-year term; and three members for a three-year term. Going forward, all future appointments shall be for a three-year term. Recommendation for appointment/reappointment are made by the Board of Supervisors and submitted to the Judge of the Frederick County Circuit Court for final appointment.)*

APRIL and MAY 2019

No appointments due for April or May.

KCT/tjp

Attachments

**INFORMATIONAL DATA SHEET
FOR
FREDERICK COUNTY BOARD OF SUPERVISORS
COMMITTEE APPOINTMENTS**

Gary Lofton, Back Creek District Supervisor, would like to nominate you to serve on the

Extension Leadership Council, Back Creek Representative

As a brief personal introduction to the other Board members, please fill out the information requested below for their review prior to filling the appointment. (Please Print Clearly. Thank You.)

Name: Brandon H. Monk Home Phone: N/A
Address: 161 Smelter Lane Office Phone: [REDACTED]
Winchester, VA 22602 Cell/Mobile: [REDACTED]
Fax: N/A
Employer: Naming Your Brand, LLC Email: [REDACTED]
Occupation: Self Employed Consultant

Civic/Community Activities: Board of Director, Virginia Association for Career and Technical Education – 2015 – 2018 ; Board of Director, Virginia Association of Agricultural Educators – 2015 – 2018 ; Association for Career and Technical Education – 2015 – 2018 ; National Association of Supervisors of Agricultural Education – 2017 – 2018 ; Producer Member, Virginia Farm Bureau Federation – 2013 – Present

Will You Be Able To Attend This Committee's Regularly Scheduled Meeting On:
Third Tuesday of each month at 4:30 p.m. Yes: No:

Do You Foresee Any Possible Conflicts Of Interest Which Might Arise By Your Serving On This Committee? Yes: No: Explain:

Additional Information Or Comments You Would Like To Provide (If you need more space, please use the reverse side or include additional sheets):

Applicant's Signature:  Date: 04/08/2019

Nominating Supervisor's Comments:

Please submit form to:
Frederick County Administrator's Office
107 North Kent Street
Winchester, VA 22601
or email to: tprice@fcva.us or jtibbs@fcva.us



March 28, 2019

Eileen E. Murphy
Commissioner of the Revenue
Frederick County, Virginia
107 North Kent Street
Winchester Virginia 22601

Re: Frederick County Board of Equalization

Dear Mrs. Murphy,

My term on the Frederick County Board of Equalization (BOE) expires December 31, 2019. Upon expiration, please be advised that I will not seek a nomination for reappointment to serve on the BOE.

I appreciate the opportunity extended to me to have served on the BOE. Serving on the BOE was a very rewarding experience.

Regards,

Luther O. Stiles

F



COUNTY of FREDERICK

Jay E. Tibbs
Deputy County Administrator
540/665-5666
Fax 540/667-0370
E-mail: jtibbs@fcva.us

MEMORANDUM

| | |
|-----------------|---|
| TO: | Board of Supervisors |
| FROM: | Jay E. Tibbs, Deputy County Administrator <i>Jay E. Tibbs</i> |
| SUBJECT: | Proposed Emergency Response Performance Guide |
| DATE: | April 15, 2019 |

At the February 21, 2019 meeting of the Public Safety Committee, the committee discussed a proposed Emergency Response Performance Guide, which would help establish response time goals for emergency incidents within Frederick County. The Public Safety Committee referred the guidelines to the Board of Supervisors with a recommendation of approval.

It was noted that the proposed guide would be discussed at the Chiefs' Working Group meeting.

At the Board of Supervisors March 13, 2019 meeting, it was noted that the proposed guide was discussed at the Chiefs' Working Group, but the Board had not received an endorsement of the proposal. The Board referred the proposed Emergency Response Performance Guide back to the Chiefs' Working Group for a recommendation.

At the March 21, 2019 meeting of the Chiefs' Working Group, the proposed Emergency Response Performance Guide was discussed and unanimously endorsed by the Chiefs' Working Group. (An excerpt of the minutes is attached to this memo.)

The proposed Emergency Response Performance Guide is back before the Board for action.

Should you have any questions, please do not hesitate to contact me.

Attachments

**FREDERICK COUNTY FIRE AND RESCUE
CHIEFS WORK GROUP MEETING
Minutes Excerpt– March 21, 2019**

- Review of the Emergency Response Performance Guide. The guide was one of the recommendations in the Study. It was presented at the Public Safety Committee and recommended to the Board of Supervisors for endorsement. CWG discussed it and reviewed the information at their February 2019 meeting. It is strictly a goal for the system, there is no punitive action for not meeting the goals, but it will give us a clear picture at how we're responding to incidents. The information contained within the Guideline was pulled from the Fire and Rescue Study, NFPA 1710, and NFPA 1720 and then combined to meet the needs of Frederick County. The initial response time goal is for 1st due responses only, the Effective Response Force time is for calls outside the 1st due and automatic / mutual aid responses. We will be able to run a report monthly to compare response times to see where improvements are needed. At the request of County Administration, they would like an endorsement from the CWG before presenting it for a final endorsement by the Board of Supervisors.
 - Chief Linaburg requested a motion to endorse the Response Guideline.
 - A motion was made by Chief Keeler, seconded by Chief Lauck.
 - The motion passed unanimously on voice vote to endorse the Response Guideline.

PUBLIC SAFETY COMMITTEE REPORT to the BOARD OF SUPERVISORS
Thursday February 21, 2019
8:30 a.m.
1080 COVERSTONE DRIVE, WINCHESTER, VIRGINIA

ATTENDEES:

Committee Members Present: Chairman Bob Wells, Walt Cunningham, Judy McCann-Slaughter, Helen Lake and Blain Dunn. Citizen member Chuck Torpy was not present.

Staff present: Director of Communications LeeAnna Pyles, Volunteer Fire & Rescue President Dan Cunningham, Deputy Chief Larry Oliver, Deputy County Administrator Jay Tibbs, Sheriff Lenny Millholland, Deputy Chief/Fire Marshal Jay Bauserman, Major Steve Hawkins, Lieutenant Warren Gosnell, County Attorney Rod Williams and Fire Marshal Kenny Scott.

ITEMS REQUIRING ACTION BY BOARD OF SUPERVISORS:

1- Proposed Emergency Response Performance Guide (see attached):

Deputy Chief Larry Oliver presented an Emergency Response Performance Guide to monitor the fire, emergency medical, and special operations systems and establish response time goals for emergency incidents within Frederick County. Currently, there is no such policy in place. This prospective guide will be discussed at the Chiefs workgroup.

Mr. Dunn made a motion to send this report, as presented, to the Board of Supervisors. Mr. Cunningham seconded the motion. The motion was unanimously approved.

ITEMS FOR INFORMATION ONLY:

1. Traffic Control reimbursement policy updated discussion (see attached):

Sheriff Millholland updated the Public Safety Committee on the traffic control reimbursement policy that was discussed at the August 16, 2018 PSC meeting. He mentioned that from July 2018- present, the Sheriff's Office has invoiced over \$47,000 for traffic control reimbursements for services rendered for VDOT needs, events and crowd control to name a few. Jay Tibbs stated that an outline showing the criteria and to whom the Sheriff's Office provides these services for would be beneficial. Sheriff Millholland stated he would produce a more in-depth explanation of services provided.

Blaine Dunn made a motion to approve the policy request and forward it on to the Finance Committee. Ms. Lake seconded the motion. The Committee unanimously approved the motion.

2. Chapter 90 and Chapter 158 Ordinance revisions (see attached):

County Attorney Rod Williams reviewed proposed revisions to Chapter 90- Fire Prevention and Protection, General Standards. This new draft updates definitions where appropriate and makes the necessary changes to the Code as reflected in the VSFPC (Virginia Statewide Fire Prevention Code). The definitions herein pertain to fire hydrants, key boxes, fire lanes, etc.

Mr. Williams also discussed proposed revisions to Chapter 158 – parking on County



COUNTY OF FREDERICK, VIRGINIA

FIRE AND RESCUE DEPARTMENT

1080 Coverstone Drive
Winchester, VA 22602

Dennis D. Linaburg
Fire Chief

TO: Frederick County Public Safety Committee

From: Dennis D. Linaburg
Fire Chief 

SUBJECT: Fire and Rescue Emergency Response Performance Guide

DATE: February 15, 2019

Developing response goals is critical to the planning process of the Department, as they impact the apparatus and system staffing needs outlined within the Fire and Rescue Study. The Department utilizes a variety of staffing and performance levels to respond to requests for service, however, baseline emergency response objectives have not been established to ensure the system is providing the most reliable service to the citizens of Frederick County.

Establishing an Emergency Response Performance Guide will allow the Department to manage and monitor the system for effective and efficient organization and deployment of fire, emergency medical and special operations to the public by the combination system to protect citizens and the occupational safety and health of all members within Frederick County Fire and Rescue.

Attached, please find a copy of the proposed Emergency Response Performance Guide for your review. At this time, we are requesting the Committee's recommendation to adopt the Emergency Response Performance Guide to allow for continued development and improved management of emergency service delivery, response capabilities and system resources.

FREDERICK COUNTY FIRE AND RESCUE DEPARTMENT STANDARD OPERATING GUIDELINE



SUBJECT: Fire and Emergency Medical Response
Performance Guide

S.O.G.:

PAGE: 1 OF 2

CATEGORY:

SUBCATEGORY:

APPROVED BY:

Dennis D. Linaburg

EFFECTIVE DATE:

CHIEF, FIRE AND RESCUE DEPARTMENT

FORMS REQUIRED:

PURPOSE

The purpose of this document is to establish response time goals for emergency incidents within Frederick County. This policy shall apply to both volunteer and career personnel and apparatus responding to emergency incidents within the County.

DEFINITIONS

Alarm Time – The time the first due company is notified of an emergency.

Dispatch Call Processing Time – The time between when the 911 call is answered and when the alert tones for responding units are activated.

Effective Response Force (ERF)- The minimum number of emergency personnel and equipment that must reach a specific emergency incident location within a maximum prescribed time.

Fire Apparatus – Any vehicle designed to be used under emergency conditions to transport personnel and equipment for the support of fire and hazardous materials suppression operations.

Response Time – The elapsed time in minutes between the alarm time and the first responding unit arriving on scene.

Rural Area – As defined by the U.S. Census Bureau, an area with fewer than 500 people per square mile.

Service Delivery – The distribution of fire and emergency resources based on community risks; allows for timely and effective emergency response.

Suburban Area – As defined by the U.S. Census Bureau, an area with between 500 and 1,000 people per square mile.

Transport Unit – Any Basic or Advanced Life Support ambulance.

Turnout Time – The elapsed time in minutes between the alarm time and the movement of the responding apparatus toward the incident.

Urban Area – As defined by the U.S. Census Bureau, an area with at least 1,000 people per square mile.

GUIDELINE

It is the intent of the Department to provide the citizens and visitors of Frederick County with services in a timely manner and to serve the community. As such, the primary performance measure is based on the first arriving fire or EMS transport unit to the scene of the emergency.

| | | |
|---|------------------------|---------------------|
| SUBJECT: Fire and Emergency Medical Response Performance Guide | EFFECTIVE DATE: | S.O.G.: |
| CATEGORY: | SUBCATEGORY: | PAGE: 2 OF 2 |

The Department hereby establishes performance measures designed to enhance the emergency services to the citizens and visitors of Frederick County by establishing a service delivery response time of 10-minutes in urban and suburban areas and 13-minutes in rural areas of Frederick County.

PROCEDURE

Frederick County Fire and Rescue has established the following emergency response performance guide:

1. Dispatch Call Processing Time
 - a. It is the goal of the Frederick County Emergency Communications Department that calls received by the Emergency Dispatch Center will be received, processed and dispatched as follows:
 - i. Medical – 2 minutes, 90% of the time
 - ii. Fire and Hazmat – 1 minute 10 seconds, 90% of the time

2. Turnout (Reaction) Time
 - a. It is the goal of Frederick County Fire and Rescue for personnel to be en-route to emergency incidents within 1 minute 30 seconds of the alarm, 90% of the time.

3. Response Time
 - a. It is the goal of Frederick County Fire and Rescue to arrive on scene with an initial suppression unit or EMS Transport Unit as follows:
 - i. Urban / Suburban Areas in less than 7 minutes, 90% of the time.
 - ii. Rural Areas in less than 10 minutes, 90% of the time.
 - b. It is the goal of Frederick County Fire and Rescue to arrive on scene with an ERF as detailed in the Frederick County Emergency Response Matrix as follows:
 - i. Urban / Suburban Areas in less than 10 minutes, 90% of the time.
 - ii. Rural Areas in less than 13 minutes, 90% of the time.
 - c. Should a response take longer, it will be reviewed for causes, and any avoidable issues should be addressed with the responding crew. Only emergency response calls will be included in the response time analysis.

4. Reports
 - a. Response time analysis reports will be generated quarterly and annually.
 - b. Reports will be utilized for monitoring, analyzing and improving emergency response times.

5. Example Emergency Response Timeframe (Medical):

| Step | Urban / Suburban | Rural |
|------------------------------------|------------------------------|------------------------------|
| 911 Call Received | Clock starts | Clock Starts |
| Emergency Processed | 2 minutes | 2 minutes |
| Company Alarm (Turnout) | 1 minute 30 seconds | 1 minute 30 seconds |
| Initial Response | 7 minutes | 10 minutes |
| Total Initial Unit Response | 10 minutes 30 seconds | 13 minutes 30 seconds |
| ERF Arrival | 3 minutes | 3 minutes |
| Total ERF Response Time | 13 minutes 30 seconds | 16 minutes 30 seconds |

G



APPLICATION FOR OUTDOOR FESTIVAL PERMIT COUNTY OF FREDERICK, VIRGINIA

(Please Print Clearly)

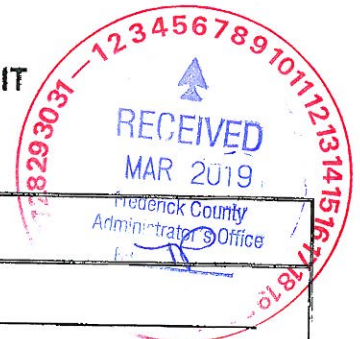

APPLICANT INFORMATION

Name of Applicant: GROVE'S WINCHESTER HARLEY-DAVIDSON

Telephone Number(s): (540) 662 - 4468 home office cell home office cell

Address: 140 INDEPENDENCE DRIVE, WINCHESTER, VA 22602

Contact Email: BARBARA@WINCHESTERHARLEY.COM

FESTIVAL EVENT ORGANIZATIONAL INFORMATION

Festival Event Name of Festival: CURVES TO CORE NATIONAL HOG RALLY

Cost of Admission to Festival: FREE Business License Obtained: Yes No

| Date(s) | Start Time | End Time | Maximum No. of Tickets Offered For Sale Per Day | Estimated No. of Attendees Per Day |
|------------------------------|------------|----------|---|------------------------------------|
| JUNE 19 TH , 2019 | 8:30 AM | 6:00 PM | N/A | 500 |
| JUNE 20 TH , 2019 | 8:30 AM | 9:00 PM | N/A | 500 |
| JUNE 21 ST , 2019 | 8:30 AM | 6:00 PM | N/A | 500 |
| JUNE 22 ND , 2019 | 8:30 AM | 7:00 PM | N/A | 500 |

Location Address: 140 INDEPENDENCE DRIVE, WINCHESTER, VA 22602

Owner of Property Name(s): BARBARA GROVE
Address: 190 BALLYGAR DRIVE, WINCHESTER, VA 22602
(*NOTE: Applicant may be required to provide a statement or other documentation indicating consent by the owner(s) for use of the property and related parking for the festival.)

Promoter Name(s): GROVE'S WINCHESTER HARLEY-DAVIDSON
Address: 140 INDEPENDENCE DRIVE, WINCHESTER, VA 22602
(*NOTE: For festivals other than not-for-profit, promoter may need to check with the Frederick County Commissioner of Revenue to determine compliance with County business license requirements; in addition, promoters who have repeat or ongoing business in Virginia may be required to register with the VA State Corporation Commission for legal authority to conduct business in Virginia.)

Financial Backer Name(s): BARBARA GROVE
Address: 190 BALLYGAR DRIVE, WINCHESTER, VA 22602

Performer Name of Person(s) or Group(s): SOULED OUT - Private Party For HOG Members only, also on Thursday June 20th, 2019

FESTIVAL EVENT LOGISTICS INFORMATION AND DOCUMENTATION

- 1. Attach a copy of the printed ticket or badge of admission to the festival, containing the date(s) and time(s) of such festival (may be marked as "sample"). copy attached OR copy to be provided as soon as available
- 2. Provide a plan for adequate sanitation facilities as well as garbage, trash, and sewage disposal for persons at the festival. This plan must meet the requirements of all state and local statutes, ordinances, and regulations, and must be approved by the VA Department of Health (Lord Fairfax Health District).

WE HAVE SUFFICIENT BATHROOM AND GARBAGE DISPOSAL ON SITE AT THE DEALERSHIP.

- 3. Provide a plan for providing food, water, and lodging for the persons at the festival. This plan must meet the requirements of all state and local statutes, ordinances, and regulations, and must be approved by the VA Department of Health (Lord Fairfax Health District).

WE HAVE LOCAL FOOD VENDOR AND SUBMITTED FORMS FOR HEALTH PERMITS. NO LODGING IS REQUIRED.

- 4. Provide a plan for adequate medical facilities for persons at the festival. This plan must meet the requirements of all state and local statutes, ordinances, and regulations, and must be approved by the County Fire Chief or Fire Marshal and the local fire and rescue company.

MILLWOOD STATION EMT

- 5. Provide a plan for adequate fire protection. This plan must meet the requirements of all state and local statutes, ordinances, and regulations, and must be approved by the County Fire Chief or Fire Marshal and the local fire and rescue company.

MILLWOOD STATION VOLUNTEER FIRE AND RESCUE WILL BE NOTIFIED ABOUT THE EVENT.

- 6. Provide a plan for adequate parking facilities and traffic control in and around the festival area. (A diagram may be submitted.)

WE HAVE SUFFICIENT PARKING AVAILABLE FOR THE EVENT.

- 7. State whether any outdoor lights or lighting will be utilized: YES NO
If yes, provide a plan or submit a diagram showing the location of such lights and the proximity relative to the property boundaries and neighboring properties. In addition, show the location of shielding devices or other equipment to be used to prevent unreasonable glow beyond the property on which the festival is located.

- 8. State whether alcoholic beverages will be served: YES NO
If yes, provide details on how it will be controlled.

CONCERN HOTLINE CHARITY

(NOTE: Evidence of any applicable VA ABC permit must also be provided and posted at the festival as required. Applicant may need to confirm with the VA ABC that a license is not required from that agency in order for festival attendees to bring their own alcoholic beverages to any event that is open to the general public upon payment of the applicable admission fee.)

FESTIVAL PROVISIONS

Applicant makes the following statements:

- A. Music shall not be rendered nor entertainment provided for more than eight (8) hours in any twenty-four (24) hour period, such twenty-four (24) hour period to be measured from the beginning of the first performance at the festival.
- B. Music shall not be played, either by mechanical device or live performance, in such a manner that the sound emanating therefrom exceeds 73 decibels at the property on which the festival is located.
- C. No person under the age of eighteen (18) years of age shall be admitted to any festival unless accompanied by a parent or guardian, the parent or guardian to remain with such person at all times. (NOTE: It may be necessary to post signs to this effect.)
- D. The Board, its lawful agents, and/or duly constituted law enforcement officers shall have permission to go upon the property where the festival is being held at any time for the purpose of determining compliance with the provisions of the County ordinance.

CERTIFICATION

I, the undersigned Applicant, hereby certify that all information, statements, and documents provided in connection with this Application are true and correct to the best of my knowledge. In addition, Applicant agrees that the festival event and its attendees shall comply with the provisions of the Frederick County ordinance pertaining to festivals as well as the festival provisions contained herein.

Barbara Grove

Signature of Applicant

BARBARA GROVE

Printed Name of Applicant

Date: FEBRUARY 9, 2019

THE BOARD SHALL HAVE THE RIGHT TO REVOKE ANY PERMIT ISSUED UNDER THIS ORDINANCE UPON NON-COMPLIANCE WITH ANY OF ITS PROVISIONS AND CONDITIONS.

H



APPLICATION FOR OUTDOOR FESTIVAL PERMIT COUNTY OF FREDERICK, VIRGINIA

(Please Print Clearly)



APPLICANT INFORMATION

Name of Applicant: GROVE'S WINCHESTER HARLEY-DAVIDSON

Telephone Number(s): (540) 662 - 4468 home office cell home office cell

Address: 140 INDEPENDENCE DRIVE, WINCHESTER, VA 22602

Contact Email: BARBARA@WINCHESTERHARLEY.COM

FESTIVAL EVENT ORGANIZATIONAL INFORMATION

Festival Event Name of Festival: VINTAGE BIKES AND SWAP MEET

Cost of Admission to Festival _____ Business License Obtained: Yes No

| Date(s) | Start Time | End Time | Maximum No. of Tickets Offered For Sale Per Day | Estimated No. of Attendees Per Day |
|---------------------------|------------|----------|---|------------------------------------|
| JUNE 15, 2019 | 10:00 AM | 5:00 PM | N/A | 500 |
| JUNE 29, 2019 (RAIN DATE) | 10:00 AM | 5:00 PM | N/A | 500 |
| | | | | |

Location Address: 140 INDEPENDENCE DRIVE, WINCHESTER, VA 22602

Owner of Property Name(s): BARBARA GROVE - JOBALIE, LLC
 Address: 190 BALLYGAR DRIVE, WINCHESTER, VA 22602
(*NOTE: Applicant may be required to provide a statement or other documentation indicating consent by the owner(s) for use of the property and related parking for the festival.)

Promoter Name(s): Larry Adams, Lost Tribe MRA
 Address(s): 235 Nightingale Ave, Stephens City, VA 22655
(*NOTE: For festivals other than not-for-profit, promoter may need to check with the Frederick County Commissioner of Revenue to determine compliance with County business license requirements; in addition, promoters who have repeat or ongoing business in Virginia may be required to register with the VA State Corporation Commission for legal authority to conduct business in Virginia.)

Financial Backer Name(s): BARBARA GROVE
 Address: 190 BALLYGAR DRIVE, WINCHESTER, VA 22602

Performer Name of Person(s) or Group(s): _____

(*NOTE: Applicant may need to update information as performers are booked for festival event.)

FESTIVAL EVENT LOGISTICS INFORMATION AND DOCUMENTATION

1. Attach a copy of the printed ticket or badge of admission to the festival, containing the date(s) and time(s) of such festival (may be marked as "sample"). copy attached OR copy to be provided as soon as available

2. Provide a plan for adequate sanitation facilities as well as garbage, trash, and sewage disposal for persons at the festival. This plan must meet the requirements of all state and local statutes, ordinances, and regulations, and must be approved by the VA Department of Health (Lord Fairfax Health District).
WE HAVE SUFFICIENT BATHROOM AND GARBAGE DISPOSAL ON SITE AT THE DEALERSHIP.

3. Provide a plan for providing food, water, and lodging for the persons at the festival. This plan must meet the requirements of all state and local statutes, ordinances, and regulations, and must be approved by the VA Department of Health (Lord Fairfax Health District).
WE HAVE LOCAL FOOD VENDOR AND SUBMITTED FORMS FOR HEALTH PERMITS. NO LODGING IS REQUIRED.

4. Provide a plan for adequate medical facilities for persons at the festival. This plan must meet the requirements of all state and local statutes, ordinances, and regulations, and must be approved by the County Fire Chief or Fire Marshal and the local fire and rescue company.
MILLWOOD STATION EMT

5. Provide a plan for adequate fire protection. This plan must meet the requirements of all state and local statutes, ordinances, and regulations, and must be approved by the County Fire Chief or Fire Marshal and the local fire and rescue company.
MILLWOOD STATION VOLUNTEER FIRE AND RESCUE WILL BE NOTIFIED ABOUT THE EVENT.

6. Provide a plan for adequate parking facilities and traffic control in and around the festival area. (A diagram may be submitted.)
WE HAVE SUFFICIENT PARKING AVAILABLE FOR THE EVENT.

7. State whether any outdoor lights or lighting will be utilized: YES NO
If yes, provide a plan or submit a diagram showing the location of such lights and the proximity relative to the property boundaries and neighboring properties. In addition, show the location of shielding devices or other equipment to be used to prevent unreasonable glow beyond the property on which the festival is located.

8. State whether alcoholic beverages will be served: YES NO
If yes, provide details on how it will be controlled.

(NOTE: Evidence of any applicable VA ABC permit must also be provided and posted at the festival as required. Applicant may need to confirm with the VA ABC that a license is not required from that agency in order for festival attendees to bring their own alcoholic beverages to any event that is open to the general public upon payment of the applicable admission fee.)

FESTIVAL PROVISIONS

Applicant makes the following statements:

- A. Music shall not be rendered nor entertainment provided for more than eight (8) hours in any twenty-four (24) hour period, such twenty-four (24) hour period to be measured from the beginning of the first performance at the festival.
- B. Music shall not be played, either by mechanical device or live performance, in such a manner that the sound emanating therefrom exceeds 73 decibels at the property on which the festival is located.
- C. No person under the age of eighteen (18) years of age shall be admitted to any festival unless accompanied by a parent or guardian, the parent or guardian to remain with such person at all times. (NOTE: It may be necessary to post signs to this effect.)
- D. The Board, its lawful agents, and/or duly constituted law enforcement officers shall have permission to go upon the property where the festival is being held at any time for the purpose of determining compliance with the provisions of the County ordinance.

CERTIFICATION

I, the undersigned Applicant, hereby certify that all information, statements, and documents provided in connection with this Application are true and correct to the best of my knowledge. In addition, Applicant agrees that the festival event and its attendees shall comply with the provisions of the Frederick County ordinance pertaining to festivals as well as the festival provisions contained herein.

Barbara Grove
Signature of Applicant

BARBARA GROVE
Printed Name of Applicant

Date: FEBRUARY 9, 2019

THE BOARD SHALL HAVE THE RIGHT TO REVOKE ANY PERMIT ISSUED UNDER THIS ORDINANCE UPON NON-COMPLIANCE WITH ANY OF ITS PROVISIONS AND CONDITIONS.

I



APPLICATION FOR OUTDOOR FESTIVAL PERMIT COUNTY OF FREDERICK, VIRGINIA

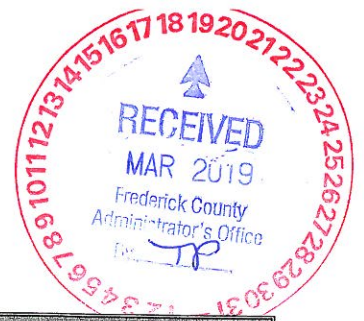

(Please Print Clearly)

| APPLICANT INFORMATION | | | | |
|--|---|--|---|------------------------------------|
| Name of Applicant: <u>Cedar Creek Battlefield Foundation</u> | | | | |
| Telephone Number(s): <u>540 869-2064</u> <input checked="" type="checkbox"/> home <input type="checkbox"/> office <input type="checkbox"/> cell <u>540 335-9518</u> <input type="checkbox"/> home <input type="checkbox"/> office <input checked="" type="checkbox"/> cell | | | | |
| Address: <u>P.O. Box 229, Middletown, VA 22645</u> | | | | |
| Contact Email: <u>info@ccbf.us</u> | | | | |
| FESTIVAL EVENT ORGANIZATIONAL INFORMATION | | | | |
| Festival Event | Name of Festival: <u>Annual Event Permit</u> | | | |
| Cost of Admission to Festival: <u>TBD</u> | | Business License Obtained: <input checked="" type="checkbox"/> Yes <input type="checkbox"/> No | | |
| Date(s) | Start Time | End Time | Maximum No. of Tickets Offered For Sale Per Day | Estimated No. of Attendees Per Day |
| Civil War Kids Day Camp <u>6/15</u> | 8:00 AM | 4:00 PM | 80 | 100-125 |
| Reenactment <u>10/18, 19, 20, 2019</u> | 9:00 AM | 6:00 PM | 7,000 | 6,000 |
| Other TBD | TBD | | | |
| Location | Address: <u>8437 Valley Pike, Middletown, VA 22645</u> | | | |
| Owner of Property | Name(s): <u>Cedar Creek Battlefield Foundation</u>
Address: <u>P.O. Box 229, Middletown, VA 22645</u>
<small>(*NOTE: Applicant may be required to provide a statement or other documentation indicating consent by the owner(s) for use of the property and related parking for the festival.)</small> | | | |
| Promoter | Name(s): <u>Cedar Creek Battlefield Foundation</u>
Address: <u>P.O. Box 229, Middletown, VA 22645</u>
<small>(*NOTE: For festivals other than not-for-profit, promoter may need to check with the Frederick County Commissioner of Revenue to determine compliance with County business license requirements; in addition, promoters who have repeat or ongoing business in Virginia may be required to register with the VA State Corporation Commission for legal authority to conduct business in Virginia.)</small> | | | |
| Financial Backer | Name(s): <u>NONE</u>
Address: _____ | | | |
| Performer | Name of Person(s) or Group(s): <u>Reenactments of historical events, civil war, living history, public participation.</u>

<small>(*NOTE: Applicant may need to update information as performers are booked for festival event.)</small> | | | |

FESTIVAL EVENT LOGISTICS INFORMATION AND DOCUMENTATION

1. Attach a copy of the printed ticket or badge of admission to the festival, containing the date(s) and time(s) of such festival (may be marked as "sample"). copy attached OR copy to be provided as soon as available

2. Provide a plan for adequate sanitation facilities as well as garbage, trash, and sewage disposal for persons at the festival. This plan must meet the requirements of all state and local statutes, ordinances, and regulations, and must be approved by the VA Department of Health (Lord Fairfax Health District).
Outdoor restrooms will be provided by Johnny Blue; Trash will be collected in dumpsters provided by D & M Container Services.

3. Provide a plan for providing food, water, and lodging for the persons at the festival. This plan must meet the requirements of all state and local statutes, ordinances, and regulations, and must be approved by the VA Department of Health (Lord Fairfax Health District).
Reenactors and other participants will bring their own food and tents for lodging.
Boyer Water Hauling will provide water for the event.
Food for spectators will be provided by Vendors permitted by Frederick County Health Department.

4. Provide a plan for adequate medical facilities for persons at the festival. This plan must meet the requirements of all state and local statutes, ordinances, and regulations, and must be approved by the County Fire Chief or Fire Marshal and the local fire and rescue company.
Middletown Fire and Rescue will be on site during the event. They will be on stand-by during off hours.

5. Provide a plan for adequate fire protection. This plan must meet the requirements of all state and local statutes, ordinances, and regulations, and must be approved by the County Fire Chief or Fire Marshal and the local fire and rescue company.
Middletown Fire and Rescue will be on site during the event. They will be on stand-by during off hours.

6. Provide a plan for adequate parking facilities and traffic control in and around the festival area. (A diagram may be submitted.)
Parking will be on lands owned and leased by Cedar Creek Battlefield Foundation. Frederick County Sheriff's Office will handle traffic on public roads and assist as needed.

7. State whether any outdoor lights or lighting will be utilized: YES NO
If yes, provide a plan or submit a diagram showing the location of such lights and the proximity relative to the property boundaries and neighboring properties. In addition, show the location of shielding devices or other equipment to be used to prevent unreasonable glow beyond the property on which the festival is located.
The Civil War Kid's Day Camp will be during daylight hours only with no lighting used.
The 153rd Anniversary Reenactment of the Battle of Cedar Creek event, CCBF will utilize a tower lighting for our registration tent from dusk to 1:00 AM. Light will be situated in the middle of a field, 150+ feet from public roads and buildings and will be pointed down.

8. State whether alcoholic beverages will be served: YES NO
If yes, provide details on how it will be controlled.

(NOTE: Evidence of any applicable VA ABC permit must also be provided and posted at the festival as required. Applicant may need to confirm with the VA ABC that a license is not required from that agency in order for festival attendees to bring their own alcoholic beverages to any event that is open to the general public upon payment of the applicable admission fee.)

FESTIVAL PROVISIONS

Applicant makes the following statements:

- A. Music shall not be rendered nor entertainment provided for more than eight (8) hours in any twenty-four (24) hour period, such twenty-four (24) hour period to be measured from the beginning of the first performance at the festival.
- B. Music shall not be played, either by mechanical device or live performance, in such a manner that the sound emanating therefrom exceeds 73 decibels at the property on which the festival is located.
- C. No person under the age of eighteen (18) years of age shall be admitted to any festival unless accompanied by a parent or guardian, the parent or guardian to remain with such person at all times. (NOTE: It may be necessary to post signs to this effect.)
- D. The Board, its lawful agents, and/or duly constituted law enforcement officers shall have permission to go upon the property where the festival is being held at any time for the purpose of determining compliance with the provisions of the County ordinance.

CERTIFICATION

I, the undersigned Applicant, hereby certify that all information, statements, and documents provided in connection with this Application are true and correct to the best of my knowledge. In addition, Applicant agrees that the festival event and its attendees shall comply with the provisions of the Frederick County ordinance pertaining to festivals as well as the festival provisions contained herein.

Patrick Kehoe 

Signature of Applicant

Patrick Kehoe, Manager, CCBF

Printed Name of Applicant

Date: March 18, 2019

THE BOARD SHALL HAVE THE RIGHT TO REVOKE ANY PERMIT ISSUED UNDER THIS ORDINANCE UPON NON-COMPLIANCE WITH ANY OF ITS PROVISIONS AND CONDITIONS.

J



COUNTY of FREDERICK

Office of the County Administrator

Tel: 540.665.6382

Fax: 540.667.0370

MEMORANDUM

To: Frederick County Board of Supervisors

From: Ann W. Phillips, Deputy Clerk

Date: April 17, 2019

Re: Amendment to Frederick County Code, Chapter 155 (Taxation), to add An Article III-A (Exemption for Surviving Spouses of Certain Persons Killed in the Line of Duty) – Ability to Limit Scope of Eligibility for Exemption

The Finance Committee discussed this item at meetings on February 26 and March 20, 2019, and at the latter meeting, recommended that the Board hold a public hearing on the topic.

In short, the proposed addition to the County Code would provide an exemption from real property taxes for surviving spouses of certain public safety personnel killed in the line of duty, as such exemption is permitted, but not required, under applicable state law, Virginia Code Title 58.1, Chapter 32, Article 2.5. As authorized under state law, the exemption would apply to the surviving spouses of sworn employees or members of, essentially, any Virginia state or local agency engaged law enforcement, corrections, firefighting, emergency medical services, civil defense (including Virginia National Guard), or emergency management.

Previously the proposed amendment was discussed at Code and Ordinance Committee Meetings held on February 11, 2019, and June 28, 2018.



ORDINANCE
___ , 2019

The Board of Supervisors of Frederick County, Virginia hereby ordains that Article III-A (Exemption for Surviving Spouses of Certain Persons Killed in the Line of Duty) of Chapter 155 (Taxation) of the Code of Frederick County, Virginia be, and the same hereby is, enacted, as follows:

CHAPTER 155 TAXATION

Article III-A Exemption for Surviving Spouses of Certain Persons Killed in the Line of Duty

§ 155-22.1 Definitions and word usage.

As used in this article, unless the context requires otherwise:

"Covered person" means any person set forth in the definition of "deceased person" in § 9.1-400 of the Code of Virginia, 1950, as amended, whose beneficiary, as defined in that section, is entitled to receive benefits under § 9.1-402 of the Code of Virginia, 1950, as amended, as determined by the Comptroller of Virginia prior to July 1, 2017, or as determined by the Virginia Retirement System on and after July 1, 2017.

§ 155-22.2 Exemption

- A. For tax years beginning on or after January 1, 2019, the real property described in subsection B, owned and occupied by the surviving spouse of any covered person as his principal place of residence is exempt from taxation. If the covered person's death occurred on or prior to January 1, 2019, and the surviving spouse has a principal residence on January 1, 2019, eligible for the exemption under this section, then the exemption for the surviving spouse shall begin on January 1, 2019. If the covered person's death occurs after January 1, 2019, and the surviving spouse has a principal residence eligible for the exemption under this section on the date that such covered person dies, then the exemption for the surviving spouse shall begin on the date that such covered person dies. If the surviving spouse acquires the property after January 1, 2019, then the exemption

shall begin on the date of acquisition, and the previous owner may be entitled to a refund for a pro rata portion of real property taxes paid pursuant to § 58.1-3360 of the Code of Virginia, 1950, as amended. The county shall not be liable for any interest on any refund due to the surviving spouse for taxes paid prior to the surviving spouse's filing of the affidavit or written statement required by § 155-22.3.

- B. Those dwellings with assessed values in the most recently ended tax year that are not in excess of the average assessed value for such year of a dwelling situated on property that is zoned as single-family residential shall qualify for a total exemption from real property taxes under this article. If the value of a dwelling is in excess of the average assessed value as described in this subsection, then only that portion of the assessed value in excess of the average assessed value shall be subject to real property taxes, and the portion of the assessed value that is not in excess of the average assessed value shall be exempt from real property taxes. Single-family homes, condominiums, town homes, manufactured homes as defined in § 46.2-100 of the Code of Virginia, 1950, as amended, whether or not the wheels and other equipment previously used for mobility have been removed, and other types of dwellings of surviving spouses, whether or not the land on which the single-family home, condominium, town home, manufactured home, or other type of dwelling of a surviving spouse is located is owned by someone other than the surviving spouse, that (i) meet this requirement and (ii) are occupied by such persons as their principal place of residence shall qualify for the real property tax exemption. If the land on which the single-family home, condominium, town home, manufactured home, or other type of dwelling is located is not owned by the surviving spouse, then the land is not exempt. For purposes of determining whether a dwelling, or a portion of its value, is exempt from real property taxes, the average assessed value shall be such average for all dwellings located within the county that are situated on property zoned as single-family residential.
- C. The surviving spouse shall qualify for the exemption so long as the surviving spouse does not remarry and continues to occupy the real property as his principal place of residence. The exemption applies without any restriction on the spouse's moving from one principal place of residence within Frederick County to a different principal place of residence within Frederick County.
- D. The exemption shall be calculated, as provided herein, based upon the taxes otherwise due for the dwelling and up to one acre of land upon which it is situated. A real property improvement other than a dwelling, made to such one acre exempt from taxation pursuant to this subsection, shall also be exempt from taxation so long as the principal use of the improvement is (a) to house or cover motor vehicles or household goods and personal effects as classified in

subdivision A 14 of § 58.1-3503 of the Code of Virginia, 1950, as amended, and as listed in § 58.1-3504 of the Code of Virginia, 1950, as amended, and (b) for other than a business purpose.

- E. For purposes of this exemption, real property of any surviving spouse of a covered person includes real property (i) held by a surviving spouse as a tenant for life, (ii) held in a revocable inter vivos trust over which the surviving spouse holds the power of revocation, or (iii) held in an irrevocable trust under which the surviving spouse possesses a life estate or enjoys a continuing right of use or support. Such real property does not include any interest held under a leasehold or term of years.
- F. 1. In the event that (i) a surviving spouse is entitled to an exemption under this section by virtue of holding the property in any of the three ways set forth in subsection E and (ii) one or more other persons have an ownership interest in the property that permits them to occupy the property, then the tax exemption for the property that otherwise would have been provided shall be prorated by multiplying the amount of the exemption by a fraction the numerator of which is 1 and the denominator of which equals the total number of people having an ownership interest that permits them to occupy the property.
2. In the event that the principal residence is jointly owned by two or more individuals including the surviving spouse, and no person is entitled to the exemption under this section by virtue of holding the property in any of the three ways set forth in subsection E, then the exemption shall be prorated by multiplying the amount of the exemption by a fraction the numerator of which is the percentage of ownership interest in the dwelling held by the surviving spouse and the denominator of which is 100.

§ 155-22.3 Application for exemption

The surviving spouse claiming the exemption under this article shall file with the Commissioner of the Revenue, on forms to be supplied by the Commissioner of the Revenue, an affidavit or written statement (i) setting forth the surviving spouse's name, (ii) indicating any other joint owners of the real property, (iii) certifying that the real property is occupied as the surviving spouse's principal place of residence, and (iv) including evidence of the determination of the Comptroller or the Virginia Retirement System pursuant to section 155-22.1. The surviving spouse shall also provide documentation that he is the surviving spouse of a covered person and of the date that the covered person died. The surviving spouse shall be required to refile the information required by this section only if the surviving spouse's principal place of residence changes. The surviving spouse shall promptly notify the Commissioner of the Revenue of any remarriage.

§ 155-22.4 Absence from residence

The fact that surviving spouses who are otherwise qualified for tax exemption pursuant to this article are residing in hospitals, nursing homes, convalescent homes, or other facilities for physical or mental care for extended periods of time shall not be construed to mean that the real estate for which tax exemption is sought does not continue to be the sole dwelling of such persons during such extended periods of other residence, so long as such real estate is not used by or leased to others for consideration.

Enacted this _____ day of _____, 2019.

| | | | |
|-----------------------------------|-------|------------------|-------|
| Charles S. DeHaven, Jr., Chairman | _____ | Gary A. Lofton | _____ |
| J. Douglas McCarthy | _____ | Robert W. Wells | _____ |
| Blaine P. Dunn | _____ | Shannon G. Trout | _____ |
| Judith McCann-Slaughter | _____ | | |

Kris C. Tierney
Clerk, Board of Supervisors
County of Frederick, Virginia

#

Article 2.5. Exemption for Surviving Spouses of Certain Persons Killed in the Line of Duty

§ 58.1-3219.13. Definitions.

As used in this article, unless the context requires otherwise:

"Covered person" means any person set forth in the definition of "deceased person" in § 9.1-400 whose beneficiary, as defined in § 9.1-400, is entitled to receive benefits under § 9.1-402, as determined by the Comptroller prior to July 1, 2017, or as determined by the Virginia Retirement System on and after July 1, 2017.

2017, c. 248.

§ 58.1-3219.14. Exemption from taxes on property of surviving spouses of certain persons killed in the line of duty.

A. Pursuant to Article X, Section 6-B of the Constitution of Virginia, for tax years beginning on or after January 1, 2017, any county, city, or town may exempt from taxation the real property described in subsection B of the surviving spouse of any covered person who occupies the real property as his principal place of residence. If the covered person's death occurred on or prior to January 1, 2017, and the surviving spouse has a principal residence on January 1, 2017, eligible for the exemption under this section, then the exemption for the surviving spouse shall begin on January 1, 2017. If the covered person's death occurs after January 1, 2017, and the surviving spouse has a principal residence eligible for the exemption under this section on the date that such covered person dies, then the exemption for the surviving spouse shall begin on the date that such covered person dies. If the surviving spouse acquires the property after January 1, 2017, then the exemption shall begin on the date of acquisition, and the previous owner may be entitled to a refund for a pro rata portion of real property taxes paid pursuant to § 58.1-3360. No county, city, or town shall be liable for any interest on any refund due to the surviving spouse for taxes paid prior to the surviving spouse's filing of the affidavit or written statement required by § 58.1-3219.15.

B. Those dwellings, in any locality that provides the exemption pursuant to this article, with assessed values in the most recently ended tax year that are not in excess of the average assessed value for such year of a dwelling situated on property that is zoned as single-family residential shall qualify for a total exemption from real property taxes under this article. If the value of a dwelling is in excess of the average assessed value as described in this subsection, then only that portion of the assessed value in excess of the average assessed value shall be subject to real property taxes, and the portion of the assessed value that is not in excess of the average assessed value shall be exempt from real property taxes. Single-family homes, condominiums, town homes, manufactured homes as defined in § 46.2-100 whether or not the wheels and other equipment previously used for mobility have been removed, and other types of dwellings of surviving spouses, whether or not the land on which the single-family home, condominium, town home, manufactured home, or other type of dwelling of a surviving spouse is located is owned by someone other than the surviving spouse, that (i) meet this requirement and (ii) are occupied by such persons as their principal place of residence shall qualify for the real property tax exemption. If the land on which the single-family home, condominium, town home,

manufactured home, or other type of dwelling is located is not owned by the surviving spouse, then the land is not exempt.

For purposes of determining whether a dwelling, or a portion of its value, is exempt from county and town real property taxes, the average assessed value shall be such average for all dwellings located within the county that are situated on property zoned as single-family residential.

C. The surviving spouse shall qualify for the exemption so long as the surviving spouse does not remarry and continues to occupy the real property as his principal place of residence. The exemption applies without any restriction on the spouse's moving to a different principal place of residence.

D. A county, city, or town shall provide for the exemption from real property taxes of (i) the qualifying dwelling, or that portion of the value of such dwelling and land that qualifies for the exemption pursuant to subsection B, and (ii) with the exception of land not owned by the surviving spouse, the land, not exceeding one acre, upon which it is situated. However, if a county, city, or town provides for an exemption from or deferral of real property taxes of more than one acre of land pursuant to Article 2 (§ 58.1-3210 et seq.), then the county, city, or town shall also provide an exemption for the same number of acres pursuant to this section. A real property improvement other than a dwelling, including the land upon which such improvement is situated, made to such one acre or greater number of acres exempt from taxation pursuant to this subsection shall also be exempt from taxation so long as the principal use of the improvement is (a) to house or cover motor vehicles or household goods and personal effects as classified in subdivision A 14 of § 58.1-3503 and as listed in § 58.1-3504 and (b) for other than a business purpose.

E. For purposes of this exemption, real property of any surviving spouse of a covered person includes real property (i) held by a surviving spouse as a tenant for life, (ii) held in a revocable inter vivos trust over which the surviving spouse holds the power of revocation, or (iii) held in an irrevocable trust under which the surviving spouse possesses a life estate or enjoys a continuing right of use or support. Such real property does not include any interest held under a leasehold or term of years.

F. 1. In the event that (i) a surviving spouse is entitled to an exemption under this section by virtue of holding the property in any of the three ways set forth in subsection E and (ii) one or more other persons have an ownership interest in the property that permits them to occupy the property, then the tax exemption for the property that otherwise would have been provided shall be prorated by multiplying the amount of the exemption by a fraction the numerator of which is 1 and the denominator of which equals the total number of people having an ownership interest that permits them to occupy the property.

2. In the event that the principal residence is jointly owned by two or more individuals including the surviving spouse, and no person is entitled to the exemption under this section by virtue of holding the property in any of the three ways set forth in subsection E, then the exemption shall be prorated by multiplying the amount of the exemption by a fraction the numerator of which is the percentage of ownership interest in the dwelling held by the surviving spouse and the denominator of which is 100.

2017, c. 248.

§ 58.1-3219.15. Application for exemption.

A. The surviving spouse claiming the exemption under this article shall file with the commissioner of the revenue of the county, city, or town or such other officer as may be designated by the governing body in which the real property is located, on forms to be supplied by the county, city, or town, an affidavit or written statement (i) setting forth the surviving spouse's name, (ii) indicating any other joint owners of the real property, (iii) certifying that the real property is occupied as the surviving spouse's principal place of residence, and (iv) including evidence of the determination of the Comptroller or the Virginia Retirement System pursuant to subsection A. The surviving spouse shall also provide documentation that he is the surviving spouse of a covered person and of the date that the covered person died.

The surviving spouse shall be required to refile the information required by this section only if the surviving spouse's principal place of residence changes.

B. The surviving spouse shall promptly notify the commissioner of the revenue of any remarriage.

2017, c. 248.

§ 58.1-3219.16. Absence from residence.

The fact that surviving spouses who are otherwise qualified for tax exemption pursuant to this article are residing in hospitals, nursing homes, convalescent homes, or other facilities for physical or mental care for extended periods of time shall not be construed to mean that the real estate for which tax exemption is sought does not continue to be the sole dwelling of such persons during such extended periods of other residence, so long as such real estate is not used by or leased to others for consideration.

2017, c. 248.

Chapter 4. Line of Duty Act.

§ 9.1-400. Title of chapter; definitions.

A. This chapter shall be known and designated as the Line of Duty Act.

B. As used in this chapter, unless the context requires a different meaning:

"Beneficiary" means the spouse of a deceased person and such persons as are entitled to take under the will of a deceased person if testate, or as his heirs at law if intestate.

"Deceased person" means any individual whose death occurs on or after April 8, 1972, in the line of duty as the direct or proximate result of the performance of his duty, including the presumptions under §§ 27-40.1, 27-40.2, 51.1-813, 65.2-402, and 65.2-402.1 if his position is covered by the applicable statute, as a law-enforcement officer of the Commonwealth or any of its political subdivisions, except employees designated pursuant to § 53.1-10 to investigate allegations of criminal behavior affecting the operations of the Department of Corrections, employees designated pursuant to § 66-3 to investigate allegations of criminal behavior affecting the operations of the Department of Juvenile Justice, and members of the investigations unit of the State Inspector General designated pursuant to § 2.2-311 to investigate allegations of criminal behavior affecting the operations of a state or nonstate agency; a correctional officer as defined in § 53.1-1; a jail officer; a regional jail or jail farm superintendent; a sheriff, deputy sheriff, or city sergeant or deputy city sergeant of the City of Richmond; a police chaplain; a member of any fire company or department or emergency medical services agency that has been recognized by an ordinance or a resolution of the governing body of any county, city, or town of the Commonwealth as an integral part of the official safety program of such county, city, or town, including a person with a recognized membership status with such fire company or department who is enrolled in a Fire Service Training course offered by the Virginia Department of Fire Programs or any fire company or department training required in pursuit of qualification to become a certified firefighter; a member of any fire company providing fire protection services for facilities of the Virginia National Guard or the Virginia Air National Guard; a member of the Virginia National Guard or the Virginia Defense Force while such member is serving in the Virginia National Guard or the Virginia Defense Force on official state duty or federal duty under Title 32 of the United States Code; any special agent of the Virginia Alcoholic Beverage Control Authority; any regular or special conservation police officer who receives compensation from a county, city, or town or from the Commonwealth appointed pursuant to the provisions of § 29.1-200; any commissioned forest warden appointed under the provisions of § 10.1-1135; any member or employee of the Virginia Marine Resources Commission granted the power of arrest pursuant to § 28.2-900; any Department of Emergency Management hazardous materials officer; any other employee of the Department of Emergency Management who is performing official duties of the agency, when those duties are related to a major disaster or emergency, as defined in § 44-146.16, that has been or is later declared to exist under the authority of the Governor in accordance with § 44-146.28; any employee of any county, city, or town performing official emergency management or emergency services duties in cooperation with the Department of Emergency Management, when those duties are related to a major disaster or emergency, as defined in § 44-146.16, that has been or is later declared to exist under the authority of the Governor in accordance with § 44-146.28 or a local emergency, as defined in § 44-146.16, declared by a local governing body; any nonfirefighter regional hazardous materials emergency response team

member; any conservation officer of the Department of Conservation and Recreation commissioned pursuant to § 10.1-115; or any full-time sworn member of the enforcement division of the Department of Motor Vehicles appointed pursuant to § 46.2-217.

"Disabled person" means any individual who has been determined to be mentally or physically incapacitated so as to prevent the further performance of his duties at the time of his disability where such incapacity is likely to be permanent, and whose incapacity occurs in the line of duty as the direct or proximate result of the performance of his duty, including the presumptions under §§ 27-40.1, 27-40.2, 51.1-813, 65.2-402, and 65.2-402.1 if his position is covered by the applicable statute, in any position listed in the definition of deceased person in this section. "Disabled person" does not include any individual who has been determined to be no longer disabled pursuant to subdivision A 2 of § 9.1-404. "Disabled person" includes any state employee included in the definition of a deceased person who was disabled on or after January 1, 1966.

"Eligible dependent" for purposes of continued health insurance pursuant to § 9.1-401 means the natural or adopted child or children of a deceased person or disabled person or of a deceased or disabled person's eligible spouse, provided that any such natural child is born as the result of a pregnancy that occurred prior to the time of the employee's death or disability and that any such adopted child is (i) adopted prior to the time of the employee's death or disability or (ii) adopted after the employee's death or disability if the adoption is pursuant to a preadoptive agreement entered into prior to the death or disability. Eligibility will continue until the end of the year in which the eligible dependent reaches age 26 or when the eligible dependent ceases to be eligible based on the Virginia Administrative Code or administrative guidance as determined by the Department of Human Resource Management.

"Eligible spouse" for purposes of continued health insurance pursuant to § 9.1-401 means the spouse of a deceased person or a disabled person at the time of the death or disability. Eligibility will continue until the eligible spouse dies, ceases to be married to a disabled person, or in the case of the spouse of a deceased person, dies, remarries on or after July 1, 2017, or otherwise ceases to be eligible based on the Virginia Administrative Code or administrative guidance as determined by the Department of Human Resource Management.

"Employee" means any person who would be covered or whose spouse, dependents, or beneficiaries would be covered under the benefits of this chapter if the person became a disabled person or a deceased person.

"Employer" means (i) the employer of a person who is a covered employee or (ii) in the case of a volunteer who is a member of any fire company or department or rescue squad described in the definition of "deceased person," the county, city, or town that by ordinance or resolution recognized such fire company or department or rescue squad as an integral part of the official safety program of such locality.

"Fund" means the Line of Duty Death and Health Benefits Trust Fund established pursuant to § 9.1-400.1.

"Line of duty" means any action the deceased or disabled person was obligated or authorized to perform by rule, regulation, condition of employment or service, or law.

"LODA Health Benefit Plans" means the separate health benefits plans established pursuant to § 9.1-401.

"Nonparticipating employer" means any employer that is a political subdivision of the Commonwealth that elected to directly fund the cost of benefits provided under this chapter and not participate in the Fund.

"Participating employer" means any employer that is a state agency or is a political subdivision of the Commonwealth that did not make an election to become a nonparticipating employer.

"VRS" means the Virginia Retirement System.

1995, cc. 112, 156, 597, §§ 2.1-133.5, 2.1-133.6; 1996, cc. 66, 174; 1998, c. 712; 2001, cc. 678, 844; 2003, cc. 37, 41, 1005; 2004, c. 30; 2005, cc. 907, 910; 2006, c. 824; 2007, c. 87; 2011, cc. 572, 586; 2012, cc. 374, 458, 573; 2015, cc. 38, 502, 503, 730; 2016, c. 677; 2017, cc. 439, 627; 2018, c. 548.

§ 9.1-400.1. Line of Duty Death and Health Benefits Trust Fund.

A. There is hereby established a permanent and perpetual fund to be known as the Line of Duty Death and Health Benefits Trust Fund, consisting of such moneys as may be appropriated by the General Assembly, contributions or reimbursements from participating and nonparticipating employers, gifts, bequests, endowments, or grants from the United States government or its agencies or instrumentalities, net income from the investment of moneys held in the Fund, and any other available sources of funds, public and private. Any moneys remaining in the Fund at the end of a biennium shall not revert to the general fund but shall remain in the Fund. Interest and income earned from the investment of such moneys shall remain in the Fund and be credited to it. The moneys in the Fund shall be (i) deemed separate and independent trust funds, (ii) segregated and accounted for separately from all other funds of the Commonwealth, and (iii) administered solely in the interests of the persons who are covered under the benefits provided pursuant to this chapter. Deposits to and assets of the Fund shall not be subject to the claims of creditors.

B. The Virginia Retirement System shall invest, reinvest, and manage the assets of the Fund as provided in § 51.1-124.39 and shall be reimbursed from the Fund for such activities as provided in that section.

C. The Fund shall be used to provide the benefits under this chapter related to disabled persons, deceased persons, eligible dependents, and eligible spouses on behalf of participating employers and to pay related administrative costs.

D. Each participating employer shall make annual contributions to the Fund and provide information as determined by VRS. The amount of the contribution for each participating employer shall be determined on a current disbursement basis in accordance with the provisions of this section. For purposes of establishing contribution amounts for participating employers, a member of any fire company or department or rescue squad that has been recognized by an ordinance or a resolution of the governing body of any locality of the Commonwealth as an integral part of the official safety program of such locality shall be considered part of the locality served by the company, department, or rescue squad. If a company, department, or rescue squad serves more than one locality, the affected localities shall determine the basis and apportionment of the required covered payroll and contributions for each company, department, or rescue squad.

If any participating employer fails to remit contributions or other fees or costs associated with the Fund, VRS shall inform the State Comptroller and the affected participating employer of the delinquent amount. In calculating the delinquent amount, VRS may impose an interest rate of

one percent per month of delinquency. The State Comptroller shall forthwith transfer such delinquent amount, plus interest, from any moneys otherwise distributable to such participating employer.

2016, c. 677;2017, c. 439.

§ 9.1-401. Continued health insurance coverage for disabled persons, eligible spouses, and eligible dependents.

A. Disabled persons, eligible spouses, and eligible dependents shall be afforded continued health insurance coverage as provided in this section, the cost of which shall be paid by the nonparticipating employer to the Department of Human Resource Management or from the Fund on behalf of a participating employer, as applicable. If any disabled person or eligible spouse is receiving the benefits described in this section and would otherwise qualify for the health insurance credit described in Chapter 14 (§ 51.1-1400 et seq.) of Title 51.1, the amount of such credit shall be deposited into the Line of Duty Death and Health Benefits Trust Fund or paid to the nonparticipating employer, as applicable, from the health insurance credit trust fund, in a manner prescribed by VRS.

B. 1. The continued health insurance coverage provided by this section for all disabled persons, eligible spouses, and eligible dependents shall be through separate plans, referred to as the LODA Health Benefits Plans (the Plans), administered by the Department of Human Resource Management. The Plans shall comply with all applicable federal and state laws and shall be modeled upon state employee health benefits program plans. Funding of the Plans' reserves and contingency shall be provided through a line of credit, the amount of which shall be based on an actuarially determined estimate of liabilities. The Department of Human Resource Management shall be reimbursed for health insurance premiums and all reasonable costs incurred and associated, directly and indirectly, in performing the duties pursuant to this section (i) from the Line of Duty Death and Health Benefits Trust Fund for costs related to disabled persons, deceased persons, eligible dependents, and eligible spouses on behalf of participating employers and (ii) from a nonparticipating employer for premiums and costs related to disabled persons, deceased persons, eligible dependents, and eligible spouses for which the nonparticipating employer is responsible. If any nonparticipating employer fails to remit such premiums and costs, the Department of Human Resource Management shall inform the State Comptroller and the affected nonparticipating employer of the delinquent amount. In calculating the delinquent amount, the Department of Human Resource Management may impose an interest rate of one percent per month of delinquency. The State Comptroller shall forthwith transfer such delinquent amount, plus interest, from any moneys otherwise distributable to such nonparticipating employer.

2. In the event that temporary health care insurance coverage is needed for disabled persons, eligible spouses, and eligible dependents during the period of transition into the LODA Health Benefits Plans, the Department of Human Resource Management is authorized to acquire and provide temporary transitional health insurance coverage. The type and source of the transitional health plans shall be within the sole discretion of the Department of Human Resource Management. Transitional coverage for eligible dependents shall comply with the eligibility criteria of the transitional plans until enrollment in the LODA Health Benefits Plan can be completed.

C. 1. a. Except as provided in subdivision 2 and any other law, continued health insurance

coverage in any LODA Health Benefits Plans shall not be provided to any person (i) whose coverage under the Plan is based on a deceased person's death or a disabled person's disability occurring on or after July 1, 2017 and (ii) who is eligible for Medicare due to age.

b. Coverage in the LODA Health Benefits Plans shall also cease for any person upon his death.

2. The provisions of subdivision 1 a shall not apply to any disabled person who is eligible for Medicare due to disability under Social Security Disability Insurance or a Railroad Retirement Board Disability Annuity. The Department of Human Resource Management may provide such disabled person coverage under a LODA Health Benefits Plan that is separate from the plan for other persons.

3. Continued health insurance under this section shall also terminate upon the disabled person's return to full duty in any position listed in the definition of deceased person in § 9.1-400. Such disabled person shall promptly notify the participating or nonparticipating employer, VRS, and the Department of Human Resource Management upon his return to work.

4. Such continued health insurance shall be suspended for the Plan year following a calendar year in which the disabled person whose coverage under the Plan is based on a disability occurring on or after July 1, 2017, has earned income in an amount equal to or greater than the salary of the position held by the disabled person at the time of disability, indexed annually based upon the annual increases in the United States Average Consumer Price Index for all items, all urban consumers (CPI-U), as published by the Bureau of Labor Statistics of the U.S. Department of Labor. Such suspension shall cease the Plan year following a calendar year in which the disabled person has not earned such amount of income. The disabled person shall notify the participating or nonparticipating employer, VRS, and the Department of Human Resource Management no later than March 1 of the year following any year in which he earns income of such amount, and notify the participating or nonparticipating employer, VRS, and the Department of Human Resource Management when he no longer is earning such amount. Upon request, a disabled person shall provide VRS and the Department of Human Resource Management with documentation of earned income.

1998, c. 712, § 2.1-133.7:1; 2000, c. 616; 2001, c. 844; 2016, c. 677; 2017, c. 439.

§ 9.1-401.1. Supplemental short-term disability benefit for state police officers.

A state police officer who is a participating employee, as defined in § 51.1-1100, and who incurs a work-related injury in the line of duty, shall receive supplemental short-term disability coverage, pursuant to § 51.1-1121, that provides income replacement for 100 percent of the officer's creditable compensation for the first six months and, pursuant to a certification by the Superintendent of State Police, based on a medical evaluation, that the officer is likely to return to service within another six months, up to one calendar year, that the officer is disabled, without regard to the officer's number of months of state service. Except as provided in this section with regard to the rate of income replacement and the duration of supplemental short-term disability coverage, such state police officers shall be eligible for work-related, supplemental short-term disability benefits upon the same terms and conditions that apply to other participating employees pursuant to Article 4 (§ 51.1-1119 et seq.) of Chapter 11 of Title 51.1. Upon the expiration of the one-calendar-year period, such state police officers shall be eligible for supplemental long-term disability benefits as provided in § 51.1-1123.

2010, c. 654.

§ 9.1-402. Payments to beneficiaries of certain deceased law-enforcement officers, firefighters, etc., and retirees.

A. The beneficiary of a deceased person whose death occurred on or before December 31, 2005, while in the line of duty as the direct or proximate result of the performance of his duty shall be entitled to receive the sum of \$75,000, which shall be paid by the nonparticipating employer or from the Fund on behalf of a participating employer, as applicable, in gratitude for and in recognition of his sacrifice on behalf of the people of the Commonwealth.

B. The beneficiary of a deceased person whose death occurred on or after January 1, 2006, while in the line of duty as the direct or proximate result of the performance of his duty shall be entitled to receive the sum of \$100,000, which shall be paid by the nonparticipating employer or from the Fund on behalf of a participating employer, as applicable, in gratitude for and in recognition of his sacrifice on behalf of the people of the Commonwealth.

C. Subject to the provisions of § 27-40.1, 27-40.2, 51.1-813, or 65.2-402, if the deceased person's death (i) arose out of and in the course of his employment or (ii) was within five years from his date of retirement, his beneficiary shall be entitled to receive the sum of \$25,000, which shall be paid by the nonparticipating employer or from the Fund on behalf of a participating employer, as applicable.

1995, cc. 156, 597, § 2.1-133.7; 2000, c. 314; 2001, c. 844; 2006, c. 878; 2016, c. 677.

§ 9.1-402.1. Payments for burial expenses.

It is the intent of the General Assembly that expeditious payments for burial expenses be made for deceased persons whose death is determined to be a direct and proximate result of their performance in the line of duty as defined by the Line of Duty Act. Upon the approval of VRS, at the request of the family of a person who may be subject to the line of duty death benefits, payments shall be made to a funeral service provider for burial and transportation costs by the nonparticipating employer or from the Fund on behalf of a participating employer, as applicable. These payments would be advanced from the death benefit that would be due to the beneficiary of the deceased person if it is determined that the person qualifies for line of duty coverage. Expenses advanced under this provision shall not exceed the coverage amounts outlined in § 65.2-512. In the event a determination is made that the death is not subject to the line of duty benefits, VRS or other Virginia governmental retirement fund of which the deceased is a member will deduct from benefit payments otherwise due to be paid to the beneficiaries of the deceased payments previously paid for burial and related transportation expenses and return such funds to the nonparticipating employer or to the Fund on behalf of a participating employer, as applicable. The Virginia Retirement System shall have the right to file a claim with the Virginia Workers' Compensation Commission against any employer to recover burial and related transportation expenses advanced under this provision.

2012, cc. 90, 576; 2016, c. 677.

§ 9.1-403. Claim for payment; costs.

A. Every beneficiary, disabled person or his spouse, or dependent of a deceased or disabled person shall present his claim to the chief officer, or his designee, of the employer for which the disabled or deceased person last worked on forms to be provided by VRS. Upon receipt of a claim, the chief officer or his designee shall forward the claim to VRS within seven days. The Virginia Retirement System shall determine eligibility for benefits under this chapter. The Virginia

Retirement System may request assistance in obtaining information necessary to make an eligibility determination from the Department of State Police. The Department of State Police shall take action to conduct the investigation as expeditiously as possible. The Department of State Police shall be reimbursed from the Fund or the nonparticipating employer, as applicable, for the cost of searching for and obtaining information requested by VRS. The Virginia Retirement System shall be reimbursed for the reasonable costs incurred for making eligibility determinations by nonparticipating employers or from the Fund on behalf of participating employers, as applicable. If any nonparticipating employer fails to reimburse VRS for reasonable costs incurred in making an eligibility determination, VRS shall inform the State Comptroller and the affected nonparticipating employer of the delinquent amount. In calculating the delinquent amount, VRS may impose an interest rate of one percent per month of delinquency. The State Comptroller shall forthwith transfer such delinquent amount, plus interest, from any moneys otherwise distributable to such nonparticipating employer.

B. 1. Within 10 business days of being notified by an employee, or an employee's representative, that such employee is permanently and totally disabled due to a work-related injury suffered in the line of duty, the agency or department employing the employee shall provide him with information about the continued health insurance coverage provided under this chapter and the process for initiating a claim. The employer shall assist in filing a claim, unless such assistance is waived by the employee or the employee's representative.

2. Within 10 business days of having knowledge that a deceased person's surviving spouse, dependents, or beneficiaries may be entitled to benefits under this chapter, the employer for which the deceased person last worked shall provide the surviving spouse, dependents, or beneficiaries, as applicable, with information about the benefits provided under this chapter and the process for initiating a claim. The employer shall assist in filing a claim, unless such assistance is waived by the surviving spouse, dependents, or beneficiaries.

C. Within 30 days of receiving a claim pursuant to subsection A, an employer may submit to VRS any evidence that could assist in determining the eligibility of a claim. However, when the claim involves a presumption under § 65.2-402 or 65.2-402.1, VRS shall provide an employer additional time to submit evidence as is necessary not to exceed nine months from the date the employer received a claim pursuant to subsection A. Any such evidence submitted by the employer shall be included in the agency record for the claim.

1995, c. 156, § 2.1-133.8; 1998, c. 712; 2001, cc. 427, 844; 2007, c. 90; 2009, cc. 393, 580; 2016, c. 677.

§ 9.1-404. Order of the Virginia Retirement System.

A. 1. The Virginia Retirement System shall make an eligibility determination within 45 days of receiving all necessary information for determining eligibility for a claim filed under § 9.1-403. The Virginia Retirement System may use a medical board pursuant to § 51.1-124.23 in determining eligibility. If benefits under this chapter are due, VRS shall notify the nonparticipating employer, which shall provide the benefits within 15 days of such notice, or VRS shall pay the benefits from the Fund on behalf of the participating employer within 15 days of the determination, as applicable. The payments shall be retroactive to the first date that the disabled person was no longer eligible for health insurance coverage subsidized by his employer.

2. Two years after an individual has been determined to be a disabled person, VRS may require the disabled person to renew the determination through a process established by VRS. If a

disabled person refuses to submit to the determination renewal process described in this subdivision, then benefits under this chapter shall cease for the individual, any eligible dependents, and an eligible spouse until the individual complies. If such individual does not comply within six months from the date of the initial request for a renewed determination, then benefits under this chapter shall permanently cease for the individual, any eligible dependents, and an eligible spouse. If VRS issues a renewed determination that an individual is no longer a disabled person, then benefits under this chapter shall permanently cease for the individual, any eligible dependents, and an eligible spouse. If VRS issues a renewed determination that an individual remains a disabled person, then VRS may require the disabled person to renew the determination five years after such renewed determination through a process established by VRS. The Virginia Retirement System may require the disabled person to renew the determination at any time if VRS has information indicating that the person may no longer be disabled.

B. The Virginia Retirement System shall be reimbursed for all reasonable costs incurred and associated, directly and indirectly, in performing the duties pursuant to this chapter (i) from the Line of Duty Death and Health Benefits Trust Fund for costs related to disabled persons, deceased persons, eligible dependents, and eligible spouses on behalf of participating employers and (ii) from a nonparticipating employer for premiums and costs related to disabled persons, deceased persons, eligible dependents, and eligible spouses for which the nonparticipating employer is responsible.

C. The Virginia Retirement System may develop policies and procedures necessary to carry out the provisions of this chapter.

1995, cc. 156, 597, § 2.1-133.9; 1998, c. 712; 2001, c. 844; 2016, c. 677; 2017, c. 439.

§ 9.1-405. Appeal from decision of Virginia Retirement System.

Any beneficiary, disabled person or eligible spouse or eligible dependent of a deceased or disabled person aggrieved by the decision of VRS may appeal the decision through a process established by VRS. Any such process may utilize a medical board as described in § 51.1-124.23. An employer may submit information related to the claim and may participate in any informal fact-finding proceeding that is included in such process established by VRS. Upon completion of the appeal process, the final determination issued by VRS shall constitute a case decision as defined in § 2.2-4001. Any beneficiary, disabled person, or eligible spouse or eligible dependent of a deceased or disabled person aggrieved by, and claiming the unlawfulness of, such case decision shall have a right to seek judicial review thereof in accordance with Article 5 (§ 2.2-4025 et seq.) of the Administrative Process Act. The employer shall not have a right to seek such judicial review.

1995, cc. 156, 597, § 2.1-133.10; 1998, c. 712; 2001, c. 844; 2016, c. 677.

§ 9.1-406. Repealed.

Repealed by Acts 2016, c. 677, cl. 2, effective July 1, 2017.

§ 9.1-407. Training.

Any employee entitled to benefits under this chapter shall receive training within 30 days of his employment, and again every two years thereafter, concerning the benefits available to himself or his beneficiary in case of disability or death in the line of duty. The Virginia Retirement System and the Department of Human Resource Management, in consultation with the Secretary of Public Safety and Homeland Security, shall develop training information to be distributed to

employers. The employer shall be responsible for providing the training. Such training shall not count toward in-service training requirements for law-enforcement officers pursuant to § 9.1-102 and shall include, but not be limited to, the general rules for intestate succession described in § 64.2-200 that may be applicable to the distribution of benefits provided under § 9.1-402.

2006, c. 535;2014, cc. 115, 490;2016, c. 677;2017, c. 439.

§ 9.1-408. Records of investigation confidential.

A. Evidence and documents obtained by or created by, and the report of investigation prepared by, the Department of State Police, the Virginia Retirement System, or the Department of Human Resource Management in carrying out the provisions of this chapter shall (i) be deemed confidential, (ii) be exempt from disclosure under the Freedom of Information Act (§ 2.2-3700 et seq.), and (iii) not be released in whole or in part by any person to any person except as provided in this chapter. Notwithstanding the provisions of this section, VRS may release to necessary parties such information, documents, and reports for purposes of administering appeals under this chapter.

B. Notwithstanding subsection A, the Department of State Police and the Department of Accounts shall, upon request, share with the Virginia Retirement System and the Department of Human Resource Management any information, evidence, documents, and reports of investigation related to existing and past claims for benefits provided under this Chapter. Such information, evidence, documents, and reports of investigation shall be exempt from disclosure under the Virginia Freedom of Information Act (§ 2.2-3700 et seq.).

2010, c. 568;2017, c. 439.

К



SITE PLAN (SUBDIVISION) #23-18
LIBERTY CHASE – 17 Lot Townhouse Subdivision
Staff Report for the Board of Supervisors
Prepared: April 16, 2019
Staff Contact: M. Tyler Klein, AICP, Senior Planner

This report is prepared by the Frederick County Planning Staff to provide information to the Planning Commission and the Board of Supervisors to assist in the review of this application. It may also be useful to others interested in this zoning matter.

| | <u>Reviewed</u> | <u>Action</u> |
|-----------------------|-----------------|------------------------|
| Planning Commission: | 04/03/19 | Information/Discussion |
| Board of Supervisors: | 04/24/19 | Information/Discussion |

LOCATION: Double Church Road (Route 641) generally north of Fairfax Pike (Route 277).

MAGISTERIAL DISTRICT: Opequon

PROPERTY ID NUMBERS: 75-A-58 & 75-A-59

PROPERTY ZONING & PRESENT USE: RP (Residential Performance) – Vacant

ADJOINING PROPERTY ZONING & USE:

| | |
|-------------------------------------|--|
| North: RP (Residential Performance) | Use: Residential (Townhomes) |
| South: RP (Residential Performance) | Use: Residential/Open Space/Double Church Road |
| East: RP (Residential Performance) | Use: Residential (Single-Family Home) |
| West: RP (Residential Performance) | Use: Residential (Single-Family Home) |

EXECUTIVE SUMMARY:

This Application is for a subdivision design plan for seventeen (17) single-family attached (townhouse) units with a minimum lot size of 1,850+/- square feet planned to be constructed on - 1.97+/- acres of land zoned RP (Residential Performance) District. The proposed subdivision lots will be accessed from Double Church Road (Route 641) via a private internal road (Stella Court). This subject property is located within the limits of the Urban Development Area (UDA) and the Sewer Water Service Area (SWSA). The 2035 Frederick County Comprehensive Policy Plan also shows this property with a residential land use designation.

The Applicant also previously received a waiver of the Master Development Plan (MDP) requirement on July 10, 2017 and has chosen to process a subdivision design plan (site plan) in lieu of the MDP. When processing a subdivision design plan in lieu of the MDP, the Application must be presented to the Planning Commission and the Board of Supervisors as an informational item. Following its presentation to the Planning Commission and the Board of Supervisors, Staff will proceed with approval of the plan.

This Application is presented for information; no action is necessary.

SUBDIVISION SPECIFICS: Subdivision of 1.97+/- acres into seventeen (17) single-family (townhouse) lots with a minimum lot size of 1,840+/- square feet (SF).

REVIEW AGENCY COMMENTS:

Virginia Department of Transportation: *See comment letter dated March 30, 2018.*

Frederick County Fire Marshall: Approved.

See comment letter dated February 14, 2018.

Building Inspections: *See comment letter dated May 11, 2018.*

Frederick County Public Works: Upon review of the revised site plan dated February 15, 2019, we recommend approval of the subject plan.

See comment letter dated March 8, 2019.

Parks and Recreation: *See comment letter dated April 10, 2018.*

GIS: Stella Court is approved for use in Liberty Chase Subdivision.

See comment letter dated May 21, 2018.

Frederick Water: *See comment letter dated April 28, 2018.*

Frederick County Public Schools: *See comment letter dated April 11, 2018.*

Planning & Development: The Subdivision Ordinance requires that land divisions in the RP (Residential Performance) Zoning District, without an approved Master Development Plan (MDP) be presented to the Planning Commission and Board of Supervisors (Chapter 144-12E). The MDP requirement may be waived under Section 165-801.03A(5) of the Frederick County Zoning Ordinance if the Applicant chooses to process a design plan in lieu of MDP:

An MDP may also be waived if the Applicant chooses to process a site plan in lieu of an MDP. The site plan must contain all information generally required on an MDP and a site plan. Once the site plan is in an administratively approvable form, the plan will be presented to the Planning Commission and the Board of Supervisors per §165-801.06.

This Application is for a subdivision design plan for seventeen (17) single-family attached (townhouse) units to be constructed on 1.97+/- acres of land zoned RP (Residential Performance) District (or 8.62 dwelling units/acre). The proposed subdivision will be accessed from Double Church (Route 641) via a private internal road (Stella Court). This subject property is located within the limits of the Urban Development Area (UDA) and the Sewer Water Service Area

(SWSA). The 2035 Frederick County Comprehensive Policy Plan also shows this property with a residential land use designation.

The Applicant also provides 25-foot wide right-of-way dedication for the future condition of Double Church Road (State Route 641) as a four-lane divided major collector roadway (as specified in the 2035 Comprehensive Plan), a 5-foot wide sidewalk for inter-parcel pedestrian connectivity, internal sidewalks and the required recreational amenities (to-be-determined at the time of construction) in the form of an outdoor pavilion, playground, tot lot, or equivalent. Further, the Applicant is providing the required buffering and screening from adjacent properties and roadways.

The Applicant previously received a waiver of the Master Development Plan (MDP) requirement on July 10, 2017 and has chosen to process a subdivision design plan (site plan) in lieu of the MDP. When processing a subdivision design plan in lieu of the MDP, the Application must be presented to the Planning Commission and the Board of Supervisors as an informational item. Following its presentation to the Planning Commission and the Board of Supervisors, Staff will proceed with approval of the plan.

STAFF CONCLUSIONS FOR THE 04/03/19 PLANNING COMMISSION MEETING:

This proposed subdivision, Liberty Chase, meets the requirements of the Frederick County Zoning and Subdivision Ordinances and is in a form that it is administratively approvable. All of the issues brought forth by the Planning Commission should be appropriately addressed by the Applicant. This is being presented as an informational item and following its presentation to the Planning Commission and the Board of Supervisors, Staff will proceed with approval of the plan.

This application is presented for information; no action is necessary.

PLANNING COMMISSION SUMMARY FOR 04/03/18 MEETING:

Staff provided a general overview of the proposed subdivision (Site Plan in lieu of a Master Development Plan (MDP)), noting it was for information purposes only. Staff explained further that the site plan was in *general* conformance with the requirements of the Frederick County Zoning and Subdivision Ordinances. Staff highlighted improvements including buffering and screening, a pedestrian connectivity, and recreational facilities including an outdoor pavilion and/or playground/to lot for residences. There was no discussion by the Planning Commission.

STAFF CONCLUSIONS FOR THE 04/24/19 BOARD OF SUPERVISORS MEETING:

This proposed subdivision, Liberty Chase, *generally* meets the requirements of the Frederick County Zoning and Subdivision Ordinances and is in a form that it is administratively approvable. All of the issues brought forth by the Planning Commission should be appropriately addressed by the Applicant. This is being presented as an informational item and following its presentation to the Planning Commission and to the Board of Supervisors, Staff will proceed with approval of the plan.

This application is presented for information; no action is necessary.





SP # 23 - 18: Liberty Chase

PINs: 75 - A - 58, 75 - A - 59

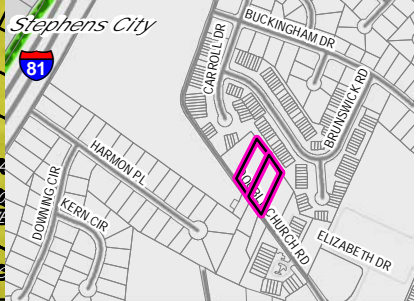
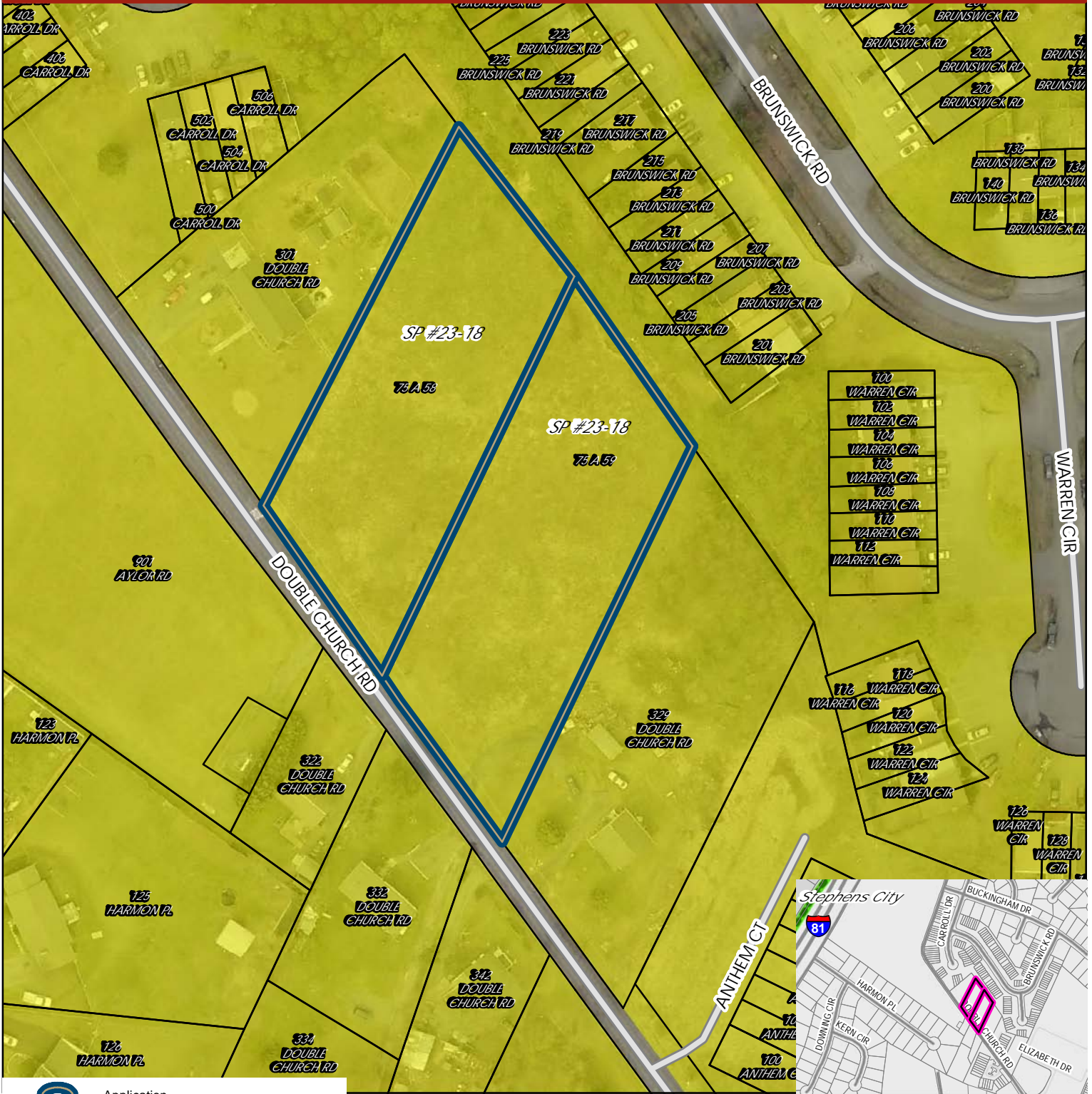
17 Lot Townhouse Subdivision

Zoning Map



-  Application
-  Parcels
-  Sewer and Water Service Area
-  RP (Residential Performance District)

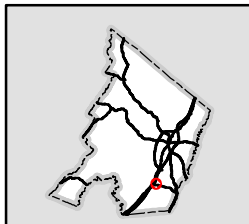





SP # 23 - 18: Liberty Chase

PINs: 75 - A - 58, 75 - A - 59

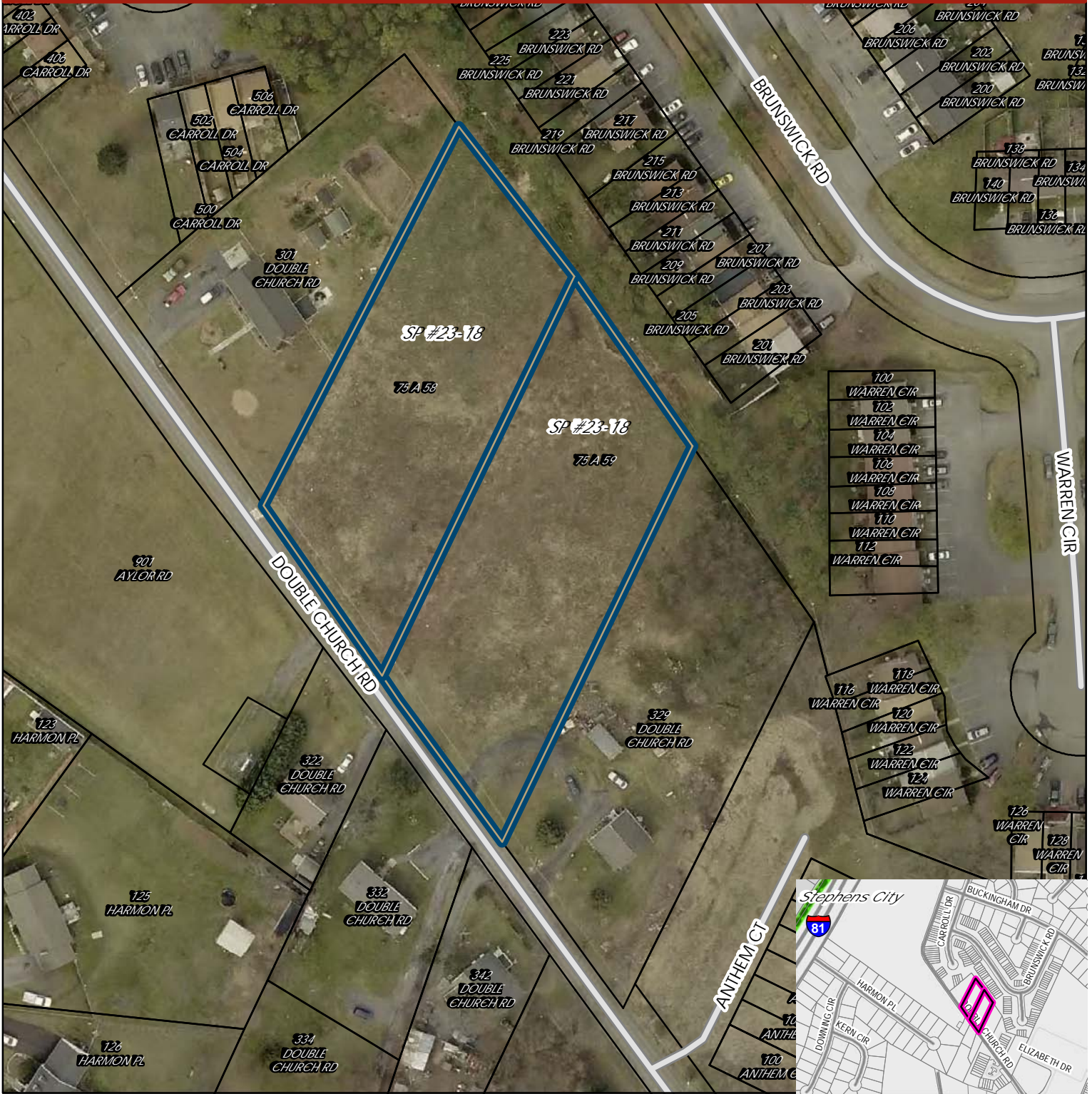
17 Lot Townhouse Subdivision

Location Map



-  Application
-  Parcels
-  Sewer and Water Service Area

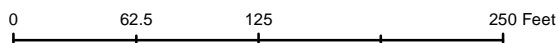
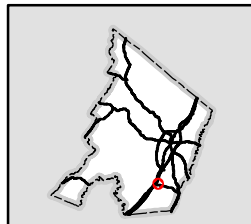

SITE PLAN APPLICATION

- Office Use Only -

Date Application Received: 5/30/18 Application #: 23-18
Fees Received: 4500⁰⁰ Receipt #: 721576 Initials: KB

1. Project Title: LIBERTY CHASE - 17 LOT TOWNHOUSE SUDIVISION

2. Location of Property DOUBLE CHURCH ROAD
(Street address) STEPEHSN CITY, VA 22655

3. Applicant/Designer:
Name: Greenway Engineering, Inc. Telephone: 540-662-4185
Address: 151 Windy Hill Lane
Winchester, VA 22602

4. Property Owner (if different than above):
Name: FREETOWN, LLC Telephone: 540-868-1818
Address: 126 LAREDO COURT
STEPHENS CITY

5. Property Information:
 - a. Property Identification Number: 75-A-58 & 75-A-59
 - b. Total acreage of the parcel to be developed: 1.9781 Acres
 - c. Total disturbed area of the parcel: 1.9 Acres
 - d. Present Use: Vacant
 - e. Proposed Use: Residential (Townhouses)
 - f. Magisterial District(s): Opequon

6. Site Plan Type:

- a. Is this an original or new site plan? Yes No
- b. Is this a revised site plan? Yes No

If yes provide all previous site plan numbers:

- c. Is this a minor site plan? Yes No

If yes provide all previous site plan numbers: _____

7. Zoning Information:

- a. Current Zoning: _____ RP
- b. Was this property Rezoned? Yes No
- c. If yes provide the rezoning number for this property: _____
- d. Are there any proffers for this property? Yes No
- e. Has a MDP been approved for this property? Yes No
- f. If yes provide the MDP number for this property: _____

8. Adjoining property zoning and use:

| | <u>USE</u> | <u>ZONING</u> |
|-------|--------------------|---------------|
| North | Residential | RP |
| East | Double Church Road | NA |
| South | Residential | RP |
| West | Residential | RP |

I have read the material included in this package and understand what is required by the Frederick County Planning Department. I also understand that all required material will be complete prior to the submission of my site plan.

Signature:  _____

Date: May 22, 2018



Special Limited Power of Attorney
County of Frederick, Virginia
Frederick Planning Website: www.co.frederick.va.us

Department of Planning & Development, County of Frederick, Virginia
107 North Kent Street, Winchester, Virginia 22601
Phone (540) 665-5651 Facsimile (540) 665-6395

Know All Men By These Presents: That I (We)

(Name) Freetown, LLC (Phone) 540-868-1818

(Address) 126 Laredo ZCourt
 the owner(s) of all those tracts or parcels of land ("Property") conveyed to me (us), by deed recorded in the Clerk's Office of the Circuit Court of the County of Frederick, Virginia, by

Instrument No. 170004041 on Page 0314-0320, and is described as

Parcel: 86 Lot: A Block: 6 Section: _____ Subdivision: _____
 do hereby make, constitute and appoint:

(Name) Greenway Engineering Inc. (Phone) 540-662-4185

(Address) 151 Windy Hill Lane, Winchester, VA 22601

To act as my true and lawful attorney -in-fact for and in my (our) name, place and stead with full power and authority I (we) would have if acting personally to file planning applications for my (our) above described Property, including:

- Rezoning (including proffers)
- Conditional Use Permit
- Master Development Plan (Preliminary and Final)
- Subdivision
- Site Plan
- Variance or Appeal

My attorney-in-fact shall have the authority to offer proffered conditions and to make amendments to previously approved proffered conditions except as follows:

This authorization shall expire one year from the day it is signed, or until it is otherwise rescinded or modified. In witness thereof, I (we) have hereto set my (our) hand and seal this 22 day of May, 2018.

Signature(s) 

State of Virginia, City/County of Frederick, To-wit:

I, Deanna D. Alexander, a Notary Public in and for the jurisdiction aforesaid, certify that the person(s) who signed to the foregoing instrument personally appeared before me and has acknowledged the same before me in the jurisdiction aforesaid this 22 day of May, 2018.

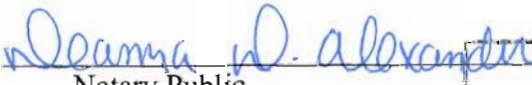
 Notary Public
 DEANNA D ALEXANDER Commission Expires: Sept. 30, 2020
 NOTARY PUBLIC
 REG. #7135427
 COMMONWEALTH OF VIRGINIA
 MY COMMISSION EXPIRES SEPT. 30, 2020

Jeremy Tweedie

From: Rhodes, Timothy <timothy.rhodes@vdot.virginia.gov>
Sent: Friday, March 30, 2018 10:33 AM
To: Randy Kepler
Cc: John Bishop (jbishop@co.frederick.va.us)"John Bishop; Rhonda (VDOT); P.E. (VDOT); Clifton M. (VDOT); Tyler Klein; Jeremy Tweedie
Subject: Liberty Chase 17 Lot Townhouse Site Plan Review

DEPARTMENT OF TRANSPORTATION
Staunton/Edinburg Land Development
14031 Old Valley Pike
Edinburg, VA 22824

Randy,

We have completed our review of the revised site plan dated March 8, 2018. We have no objection to the proposed site plan. Please send signature copies to this office for final VDOT review/ Approval.

Thank You,

Timothy Rhodes

VDOT~Land Development Engineer
Clarke, Frederick, Shenandoah & Warren Counties
14031 Old Valley Pike
Edinburg, VA. 22824
(540)-984-5630

Tyler Klein

From: Rhodes, Timothy (VDOT) <Timothy.Rhodes@vdot.virginia.gov>
Sent: Wednesday, March 07, 2018 10:10 AM
To: 'Randy Kepler'
Cc: John Bishop; Funkhouser, Rhonda (VDOT); Smith, Matthew, P.E. (VDOT); Balderson, Clifton M. (VDOT); Tyler Klein; 'Jeremy Tweedie'
Subject: Freedom Crossing 7 Lot Townhomes Site Plan Review Comments



Randy,

A VDOT review has been conducted on the Liberty Chase 17 Lot Townhouse Site Plan dated February 12, 2018. We offer the following comments:

- Multiple notes on the plan sheets overlap one another making them non legible. Please revise.
- The Staunton District trip rate used for townhomes is 8.145. Please show this trip rate on plans.
- Please identify the CG-12 type. (A,B,C)
- In plan view, please include placement of UD-4 as well as the outfall to the EW-12.
- The typical section shows the proposed right-of-way at 25' and the plan view shows the proposed right-of-way at 27'. Please correct discrepancy.
- Plan sheets 6, 10 and 11 note the existing ditch at the west end of the property to remain in a curb and gutter area. Please remove the note as the CG-6 extends to the property line.
- Please provide the distance to the nearest intersection in each direction.
- Please provide the line of sight, sight distance triangles in each direction.
- Please note the location of the stop bar to be determined by VDOT inspector.
- In plan view, please show the limits of mill and overlay extending through the adjacent travel lane per VDOT WP-2 Standard Detail.
- Please add a note to the wet tap for the water line that pavement restoration to be in accordance with VDOT LUP OC, open cut pavement restoration. The LUP-OC Detail is to be included in the plan set.

Please provide a resolution for the above comments by sending two sets of revised drawings, a comment response letter, and highlighted plan showing changes, as well as one digital copy of the plans. Should you have any questions, please feel free to contact me.

Thank You,

REQUEST FOR SITE PLAN COMMENTS



Frederick County Fire Marshal Comment

Mail to:

Frederick County Fire Marshal
Attn: Fire Marshal
1800 Coverstone Drive
Winchester, Virginia 22602

Hand deliver to:

Public Safety Building
1080 Coverstone Drive
Winchester, Virginia 22602
Phone: (540) 665-6350

Applicant: It is your responsibility to complete this form as accurately as possible in order to assist the agency with their review. Please attach two (2) copies of the Site Plan with this sheet.

Applicant's Name: Greenway Engineering Inc. Telephone: 540 662 4185

Mailing Address: 151 Windy Hill Lane
Winchester VA, 22601

Name of development and/or description of the request:
Liberty Chase 171 OT TOWNHOUSE SUBDIVISION

Location of Property:
Double Church Road
Stephens City, VA 22655

Fire Marshal Comments:
See Attachments

-FREDERICK COUNTY FIRE MARSHAL USE ONLY-

Date Received
Date Reviewed
Revision Required
Signature & Date: [Signature]

Review Number 1 2 3 4 5 (circle one)
Date Approved

** Please Return Form to Applicant**

RECEIVED FEB 14 2018



Frederick County
Department of Fire and Rescue
Office of the Fire Marshal
 1080 Coverstone Drive Winchester, VA 22602

(540) 665-6350 Fax: (540) 678-4739 Email: fmo@fcva.us

Plan Review & Comments

Date Received
2/14/2018

Date Reviewed
2/16/2018

Plan/Permit Type **Site Plan 02-14-18**

Name **Liberty Chase Townhomes**

Address **Double Church RD Stephens City VA 22655**

Project Name **Townhouse Subdivision**

Applicant Name & Number **Greenway Engineering 540-662-4185**

RE#

Permit Number

| | | | |
|---------------------------|---------------------|------------|----------------|
| Emergency Vehicle Access: | Adequate | Inadequate | N/A |
| Hydrant Location: | Adequate | Inadequate | N/A |
| Siamese Location: | Adequate | Inadequate | N/A |
| Fire Lanes Required: | Yes | No | N/A |

Plan Approval Status **Approve**

Comments

Areas hi lighted in orange shall have No Parking Fire Lane signs installed
Areas hi lighted in yellow shall be striped in yellow

Signature: 

Reviewed By: **Kenneth Scott, Jr.**

Title: 

REQUEST FOR SITE PLAN COMMENTS



**Frederick County Inspections
Department Comment**

Mail to:

Frederick County Inspections Department
Attn: Building Official
107 North Kent Street,
Winchester, Virginia 22601

Hand deliver to:

Frederick County Inspections Dept.
107 North Kent Street, 2nd Floor
Winchester, Virginia 22601
Phone: (540) 665-5650

Applicant: It is your responsibility to complete this form as accurately as possible in order to assist the agency with their review. Please attach two (2) copies of the Site Plan with this sheet.

Applicant's Name: Greenway Engineering Inc.

Telephone: 540-662-4185

Mailing Address: 151 Windy Hill Lane
Winchester VA, 22601

Name of development and/or description of the request:

Liberty Chase - 17 LOT TOWNHOUSE SUDIVISION

Location of Property:

Double Church Road

Stephens City, VA 22655

Inspections Department Comments:

Comments are on the back of this form

-FREDERICK COUNTY INSPECTIONS DEPARTMENT USE ONLY-

Date Received 3/27/18

Review Number 1: 2 3 4 5 (circle one)

Date Reviewed 5/11/18

Revision Required N/A

Date Approved 5/11/18

Signature & Date: Mark Heel R 5/11/18

**** Please Return Form to Applicant****

RECEIVED

MAY 11 2018

**GREENWAY
ENGINEERING**

Project shall comply with The Virginia Uniform Statewide Building Code (USBC). Dwellings (R-5) shall comply with The Virginia Residential 2012 Codes. Other Codes that apply are the 2009 ANSI A117.1-09 Accessible and Usable Buildings and Facilities and the 2012 Virginia Energy Code

Dwellings (townhouses) shall be separated as required for per Section R 302.2. All recreational facilities shall be provided with an accessible route. sidewalk provided to recreational area. Walkway shall not exceed 5%.

Engineer Design required on all foundations and/or slabs with greater than 8" fill or 24" clean sand/gravel.

Engineer design may be required under R610 for windbracing requirements

Backwater valves shall be installed on all plumbing fixtures, (subject to back sewer), located below the top elevation of the upstream man hole cover.

Storm water drains, if higher than the basement finished floor, may require additional engineering of the foundation

Grade shall be sloped away from foundations a min 6" in 10'.

Site plan approved pending receipt of geotechnical soil investigation as required.



COUNTY of FREDERICK

Department of Public Works

540/665-5643

FAX: 540/678-0682

March 8, 2019

Mr. Jeremy Tweedie
Greenway Engineering, Inc.
151 Windy Hill Lane
Winchester, Virginia 22601

RE: Revised Site Plan Comments – Liberty Chase

Dear Mr. Tweedie:

Upon review of the revised site plan dated February 15, 2019, we recommend approval of the subject plan.

Joseph W. Johnson, P.E.
Civil Engineer

Sincerely,

Joe C. Wilder
Director of Public Works

JCW/kco

cc: Planning and Development
file

REQUEST FOR SITE PLAN COMMENTS



Frederick County Parks and Recreation Comment

Mail to:

Frederick County
Department of Parks & Recreation
107 North Kent Street
Winchester, Virginia 22601

Hand deliver to:

107 North Kent Street
Second Floor
Winchester, Virginia 22601
Phone: (540) 665-5678

Applicant: It is your responsibility to complete this form as accurately as possible in order to assist the agency with their review. Please attach one (1) copy of the Site Plan with this sheet

Applicant's Name: Greenway Engineering Inc.

Telephone: 540-662-4185

Mailing Address: 151 Windy Hill Lane
Winchester VA, 22601

Name of development and/or description of the request:

Liberty Chase - 17 LOT TOWNHOUSE SUDIVISION

Location of Property:

Double Church Road
Stephens City, VA 22655

Parks and Recreation Comments:

Plans updated to show accurate open space provision in excess of
30% and Recreation visit requirement obligation of .58 units appear
to meet Parks + Recreation requirements.

-FREDERICK COUNTY PARKS AND RECREATION USE ONLY-

Date Received _____

Review Number 1 2 3 4 5 (circle one)

Date Reviewed _____

Revision Required _____

Date Approved _____

Signature & Date:

Jonathan Leibel 4.10.15

**** Please Return Form to Applicant****

REQUEST FOR SUBDIVISION PLAN COMMENTS



Request for Street Name Comment

Mail to:

Frederick County
Information Technologies, GIS Division
Attn: GIS Manager
107 North Kent Street,
Winchester, Virginia 22601

Hand deliver to:

Frederick County
Information Technologies, GIS Division
107 North Kent Street, 1st Floor
Winchester, Virginia 22601
Phone: (540) 665-5614

Applicant: It is your responsibility to complete this form as accurately as possible in order to assist the agency with their review. Please attach two (2) copies of the Subdivision Design Plan with this sheet.

Applicant's Name: Greenway Engineering Telephone: 540-662-4185

Mailing Address: Greenway Engineering
151 Windy Hill Ln
Winchester VA 22602

Name of development and/or description of the request:
Liberty Chase - 17 Lot Townhouse Subdivision

Location of Property:
Double Church Rd, Stephens City VA, 22655

GIS Manager Comments:
Stella Court is approved for use in Liberty Chase Subdivision

-GIS MANAGER USE ONLY-

Date Received Mar 27, 2018
Date Reviewed May 18, 2018
Revision Required NO

Review Number 1 2 3 4 5 (circle one)

Date Approved 5/21/18

Signature & Date: *Patricia V. J.*

**** Please Return Form to Applicant****



FREDERICK WATER

SITE PLAN REVIEW COMMENTS

PO Box 1877, Winchester, VA 22604-8377
315 Tasker Road, Stephens City, VA 22655

540.868.1061 voice
540.868.1429 fax

Project LIBERTY CHASE

Applicant GREENWAY

REVIEW STATUS 03 attention JEREMY TWEDDIE

review number 03
correct & resubmit _____ approved as noted _____ number of items to be corrected 0/0

approved **You may submit just cover sheet and the revised sheets.**

DRAWINGS
send me by 5/17/18

- 1. print of sheets (2) sets ALL
- 2. two CDs: each disc shall contain the following plan sheets ALL

- a) One CD (containing all of the above noted sheets) shall be in PDF format. Each sheet shall be in its own file and be in landscape orientation. Each file shall be titled with the project name and appropriate sheet number.
- b) One CD shall be in DWG format: (1) in Model Space, (2) in state plane coordinate system NAD 83, (3) compatible with AutoCAD 2006.
- c) Each of the two CDs shall be labeled with its format and project name, and placed in its own paper CD envelope.

EASEMENTS

- Y / N A copy of the recorded onsite FW easement(s) is/are required.
- Y / N A copy of the recorded offsite FW easement(s) is/are required.
 - The easement document shall contain a plat and both shall be signed by the Frederick Water.
 - The Frederick Water requires specific language in its deed of easement.
 - Visit our website www.frederickwater.com to obtain a copy of the form.
 - A copy of the recorded deed(s) of easement shall be received before service will be authorized.

OTHER

- Y / N This project also requires DEQ - Valley Region Office approval.
- Y / N This project also requires VDH - Lexington Field Office approval.
- Y / N This project also requires VDH - Lexington Field Office - Project Summary Report. **BY DATE FOR DRAWINGS ABOVE, see VDH website for form**
- Y / N This project has a sewer pump station that FW will own. Title to the pump station site shall be granted to the Frederick Water in fee simple absolute. Also, (1) a copy of DEQ's Certificate to Construct, (2) a copy of DEQ's Certificate to Operate, and (3) two copies of the FW approved O & M manual are required. These documents must be received before service will be authorized. (4) Work cannot commence that would connect to FW facilities or require FW inspections until the contract is returned to this office.

Date: 4/23/18

E. W. Wiley
Earl W. Wiley - Engineering Assistant

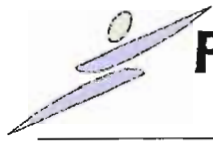

Frederick County Public Schools

... to ensure all students an excellent education

K. Wayne Lee, Jr. ALEP, LEED AP • Coordinator of Planning and Development • leew@fcpsk12.net

April 11, 2018

Mr. Jeremy Tweedie
Greenway Engineering
151 Windy Hill Lane
Winchester, VA 22602

Re: Liberty Chase Site Plan Application

Dear Mr. Tweedie:

Frederick County Public Schools has reviewed the Liberty Chase site plan application submitted to us on March 27, 2018. We offer the following comments:

1. The cumulative impact of this development and other developments in Frederick County will require construction of new schools and support facilities to accommodate increased student enrollment. This development proposal includes 17 single-family attached units. We estimate that this development will house 4 students: 1 high school student, 1 middle school student, and 2 elementary school students. In order to properly serve these additional students, Frederick County Public Schools would spend an estimated \$50,000 more per year in operating costs (or \$2,941 average per unit per year) and an estimated \$183,000 in one-time capital expenditures (or \$10,765 average per unit). You will find, attached to this letter, a more detailed assessment of the estimated impact of Liberty Chase on FCPS, including attendance zone information.
2. It is noted that Stella Court will be a private road. As our buses don't travel down private roads, students who live in Liberty Chase will need to walk to a bus stop located on a public street at a location designated by our Transportation Department.

Please feel free to contact me at leew@fcpsk12.net or 540-662-3888 x88249 if you have any questions or comments.

Sincerely,

K. Wayne Lee, Jr., ALEP, LEED AP
Coordinator of Planning and Development

attachment

cc: Dr. David Sovine, Superintendent of Schools
Mr. Albert Orndorff, Assistant Superintendent for Administration
Mr. John Grubbs, Transportation Director
Mrs. Beth Brown, Supervisor of Driver Operations

| Plan Revisions | |
|----------------|---------|
| Date | Comment |
| | |
| | |
| | |
| | |
| | |
| | |
| | |
| | |
| | |
| | |
| | |
| | |
| | |
| | |
| | |

LIBERTY CHASE - 17 LOT TOWNHOUSE SUBDIVISION DESIGN SITE PLAN #23-18

OPEQUON MAGISTERIAL DISTRICT
FREDERICK COUNTY, VIRGINIA

| Sheet Number | Sheet Title |
|--------------|--|
| 1 | Cover Sheet |
| 2 | General Notes and Legend |
| 3 | Boundary and Existing Topo |
| 4 | E&S Phase I & II |
| 5 | E&S Details |
| 6 | Geometry Plan |
| 7 | Grading Plan |
| 8 | Stormwater Management & Water Quality Plan |
| 9 | Storm Sewer Comps |
| 10 | Landscape & Site Lighting Plan |
| 11 | Utility Profiles |
| 12 | Life Safety Plan |
| 13 | VDDT Details |
| 14 | Frederick Water Details |

151 Windy Hill Lane
Winchester, Virginia 22602
Telephone: (540) 662-4185
Fax: (540) 722-9528
www.greenwayeng.com



PROUDLY SERVING VIRGINIA & WEST VIRGINIA
OFFICES IN: WINCHESTER, VA & MARTINSBURG, WV



CALL "MISS UTILITY"
VIRGINIA UTILITY PROTECTION SERVICE (VUPS) AT 811 OR 1-800-552-7001, 48 HOURS PRIOR TO THE START OF WORK. EXCAVATORS MUST NOTIFY ALL PUBLIC UTILITY OPERATORS WHO MAINTAIN UNDERGROUND UTILITY LINES IN THE AREA OF PROPOSED EXCAVATING OR BLASTING AND HAVE THOSE FACILITIES LOCATED BY THE UTILITY COMPANIES PRIOR TO COMMENCING EXCAVATION. THE EXCAVATOR IS RESPONSIBLE FOR COMPLIANCE WITH ALL COUNTY REQUIREMENTS, VIRGINIA CODE AND REGULATIONS.

UTILITY NOTICE REQUIRED
Contractors shall notify all public utility operators who maintain underground utility lines in the area of proposed excavating or blasting at least two (2) working days, but not more than ten (10) working days, prior to commencement of excavation or demolition. Names and telephone numbers of the operators of underground utility lines appear below. These numbers shall also be used to serve in an emergency condition.

Water/Sewer: Frederick Water
P.O. Box 1877
Winchester, VA, 22604
(540) 668-1061

Power: Rappahannock Electric Coop
137 Kelly Court
Front Royal, VA 22630
1-800-552-3904

Phone: Verizon
P.O. Box 17398
Baltimore, MD 21297
(301) 954-6282

Gas: Shenandoah Gas Co.
P.O. Box 2400
Winchester, VA 22604
(540) 669-1111

OWNER
FREETOWN, LLC
P.O. BOX 604
STEPHENS CITY, VA 22655
540-866-1818

VICINITY MAP
SCALE: 1" = 1000'

DEVELOPER
TRUSTLAND INC
P.O. BOX 604
STEPHENS CITY, VA 22655
540-869-1818

OWNERS CERTIFICATE

The foregoing Subdivision of the land of
FREETOWN, LLC
is with the free consent and in accordance with the
desires of the undersigned owners, properties and trustees
if any.

DATE

APPROVALS

ZONING & SUBDIVISION ADMINISTRATOR DATE

DATE

THESE PLANS ARE IN CONFORMANCE WITH FREDERICK COUNTY
STANDARDS AND ORDINANCES. ANY DEVIATION OR CHANGE IN THESE
PLANS SHALL BE APPROVED BY THE ZONING ADMINISTRATOR PRIOR
TO CONSTRUCTION.

COVER SHEET
**LIBERTY CHASE - 17 LOT
TOWNHOUSE**
OPEQUON MAGISTERIAL DISTRICT
FREDERICK COUNTY, VIRGINIA

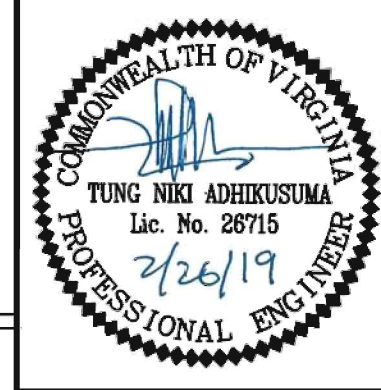

DATE: 2-15-2019
SCALE: N/A
DESIGNED BY: JNT
FILE NO. 4634T
SHEET 1 OF 14
15-19

GENERAL NOTES

- Greenway Engineering, Inc. (GE) issued this plan set based on project criteria dictated by the client and municipal codes. This plan set is not considered complete or appropriate for construction until ALL necessary agencies have given approval AND this plan set is signed and sealed by a licensed professional. Any work, planning, scheduling, material purchases and/or construction prior to approvals and licensed/professional sealing will be performed at the risk of the personnel authorizing work. GE shall be held harmless from and costs, time delay and/or material changes incurred on work started before this plan set receives approvals and seals.
- Methods and materials used in the construction of the improvements herein shall conform to current County Construction Standards and Specifications and/or current VDOT Standards and Specifications.
- The Engineer shall not have control over or charge of and shall not be responsible for construction means, methods, techniques, sequences or procedures nor for safety precautions and programs in connection with work shown on these plans. The Engineer is not responsible for the contractor's schedules or failure to carry out the work. The Engineer is not responsible for acts of omissions of the contractor, subcontractor, or their agents or employees, or any other person performing portions of the work.
- The Contractor/Owner or Developer shall be responsible for securing any third party inspection/testing service to insure construction compliance with these plans and specifications. It is Greenway Engineering's recommendation that a third party inspection/testing service be employed to ensure that project is completed and materials installed meet the details and specifications in these plans.
- The location of existing utilities shown in these plans are taken from existing records. It shall be the contractor's responsibility to verify the exact horizontal and vertical location of all existing utilities as needed prior to construction. The contractor shall be responsible for the digging of all test holes that may be required, whether recommended or not by these plans, to determine the exact location and elevation of existing utilities. If any conflicts arising from this existing utility verification or if during the course of construction, any object of an unusual nature is encountered, the contractor shall cease work in that area and immediately notify Greenway Engineering at (540) 682-4185 and/or the proper authority. Greenway Engineering or any engineer associated with these plans shall not be responsible or liable for any construction cost that may be associated with the installation or reinstallation any utility or other improvements if not notified of any discrepancies between actual field conditions and the approved plan.
- The approval of these plans in no way relieve the developer, the contractor, or their agents of any legal responsibility which may be required by the code of Virginia or any other ordinance enacted by the County nor does it guarantee the issuance of any required permit by the County, VDOT or any other Agency.
- An approved set of plans and all applicable permits must be available at the construction site at all times during construction. A representative of the developer must be available at all times.
- Prior to the initiation of any land disturbing activities the Developer, the Contractor or the Responsible Land Disturber shall obtain a Land Disturbance Permit from the County Engineer's office. The Contractor, Developer or his agent shall be responsible for obtaining a Virginia Stormwater Management Program (VSWMP) Permit and shall be responsible for the registration of the construction site as required by law. They shall also be responsible for obtaining and maintaining on site a Stormwater Pollution Prevention Plan (SWPPP). The approval of these plans in no way relieves the developer or his agent of the responsibilities contained in the Virginia Erosion and Sediment Control Handbook.
- The Developer or his agent shall be responsible for obtaining any required permits from the Virginia Department of Environmental Quality (DEQ) or the United States Army Corp of Engineers for any plan wetland disturbance as shown on these plans. They shall also be responsible the identification and delineation of any wetlands that may be present on the construction site.
- The contractor shall provide adequate means of cleaning mud from trucks and/or other equipment prior to entering public streets, and it is the contractor's responsibility to clean streets, alley dust, and to take whatever measures necessary to insure that public streets are maintained in a clean, mud and dust free condition at all times.
- A permit must be obtained from the Office of the Resident Engineer, Virginia Department of Transportation (VDOT) and Frederick County prior to any construction activities within existing State right-of-way.
- The developer will be responsible for any damage to the existing streets and utilities which occurs as a result of his construction project within or contiguous to the existing right-of-way.
- Warning signs, markers, barricades or flagmen should be in accordance with the State and Federal Manual on Uniform Traffic Control Devices (MUTCD).
- The exact location of all guard rails and paved ditches will be determined by VDOT personnel. A joint inspection will be held with the Developer, County Representatives, and Representatives of the Virginia Department of Transportation (VDOT) to determine if and where guard rail and/or paved ditches will be needed. The developer will be responsible for providing guardrail and paved ditches as determined by this joint inspection." Refer to Virginia Department of Transportation (VDOT) Guard Rail and Paved Ditch Specifications.
- All unsuitable material shall be removed from the construction limits of the site plan before placing embankment.
- All pavement sections shown on these approved plans are based on a minimum CBR value of 6 and are for preliminary design only. Final pavement design shall be based upon actual field tested CBR values. The Contractor or Developer shall be responsible for field tests per VDOT standards to obtain actual CBR values for final design. Final pavement designs will be approved by VDOT and/or the Owner/Developer, which ever applicable, prior to installation.
- All springs shall be capped and piped to the nearest storm sewer manholes or curb inlet. The pipe shall be minimum 6" diameter and conform to VDOT standard SB-1.
- When grading is proposed within easements of utilities, letters of permission from all involved companies must be provided to the County Public Works Department prior to issuance of grading and/or site development permits.
- Notification shall be given to the appropriate utility company prior to construction of water and/or sanitary sewer lines. Information should also be obtained from the appropriate authority concerning permits, cut sheets, and connections to existing lines.
- The Developer and/or Contractor shall be responsible to supply all utility companies with copies of the approved plans and advise them that all grading shall conform to the approved plans, and further that the utility companies shall be responsible for honoring these plans and the finished grades in the installation of their utility lines.
- All utilities to be located underground.
- Contractors shall notify operators who maintain underground utility lines in the area of proposed excavating or blasting at least two (2) working days, but not more than ten (10) working days, prior to commencement of excavation or demolition.
- The developer will be responsible for the relocation of any utilities which is required as a result of his project. The relocation should be done prior to construction.
- All parking lot/street light and dry utility design shall be performed and provided separately by others. All electrical and lighting information shown hereon is as specified by others and is included for informational purposes only, as directed by the Owner, Developer and/or public agency requirements. Greenway Engineering has not performed the lighting and/or dry utility design and does not warrant and is not responsible for the degree and/or adequacy of illumination on this project or the adequacy of the dry utility to service the site.
- All sanitary sewers, water mains and appurtenances shall be constructed in accordance with the current standards and specifications of the Frederick County Sanitation Authority.
- All stormwater piping and structures shown on these plans are only accurate to the inlet or manhole locations as shown hereon. Detail design of stormwater structures were not provided to Greenway Engineering. Actual pipe alignments will be based upon developed structural shop drawings as provided by the manufacturer. Contractor shall make adjustments to pipe alignments based on provided shop drawings. Greenway Engineering will not be held responsible or liable for any discrepancies or changes caused by the structural design. Contractor may submit shop drawings to Greenway Engineering for review and approval at contractor's expense. Shop drawings will be reviewed for compliance with design plans. The Owner or Developer will be responsible for any redesign as a result of structural shop drawing design.
- Controlled fills shall be compacted to 95% of maximum density as determined by method "A" per standard T98, ASTM-D698, or VTM-1 as applicable. Density shall be certified by a registered professional engineer and results submitted to Frederick County prior to pavement construction. If a geotechnical report has been prepared, it should supersede the requirements in this note.
- Refer to Geotechnical Engineer for methods, materials and details for construction of all earthwork activities.
- Any retaining wall 2 ft. or greater in height shall require the issuance of a separate building permit.
- Construction debris shall be containerized in accordance with the Virginia Litter Control Act; no less than one liter receptacle shall be provided at the construction site.
- These plans identify the location of all known gravesites. Gravesites shown on this plan will be protected in accordance with state law. In the event gravesites are discovered during construction, the owner and engineer must be notified immediately.
- Individual sign permits will be required from the Zoning Office for all free standing and/or facade signs prior to erecting the sign and may require a separate building permit.

FIRE MARSHAL'S NOTE

Fire Lane markings and signage:
Any "No Parking" signs and yellow painted locations will be installed by field inspection at the direction of the Fire Marshal's Office.

VDOT GENERAL NOTES

- All work on this project shall conform to the current editions of and latest revisions to the Virginia Department of Transportation (VDOT) Road and Bridge Specifications and Standards, the Virginia Erosion and Sediment Control Regulations, and any other applicable state, federal or local regulations. In case of a discrepancy or conflict between the Standards or Specifications and Regulations, the most stringent shall govern.
- All construction shall comply with the latest U.S. Department of Labor, Occupational Safety and Health Administration (OSHA), and Virginia Occupational Safety & Health (VOSH) Rules and Regulations.
- When working within VDOT right-of-way, all traffic control, whether permanent or temporary, shall be in accordance with the current edition of VDOT's Work Area Protection Manual. A transportation plan needs to be submitted for approval and land use permit issued prior to any execution of work within the VDOT right of way.
- The developer shall be responsible for relocating, at his expense, any and all utilities, including traffic signal poles, junction boxes, controllers, etc., owned by VDOT or private / public utility companies. It is the sole responsibility of the developer to locate and identify utility facilities or items that may be in conflict with the proposed construction activity. VDOT approval of these plans does not indemnify the developer from this responsibility.
- Design features relating to field construction, regulations, and control or safety of traffic may be subject to change as deemed necessary by VDOT. Any additional expense incurred as a result of any field revision shall be the responsibility of the developer.
- If required by the local VDOT Land Development Office, a pre-construction conference shall be arranged and held by the engineer and/or developer with the attendance of the contractor (s), various County agencies, utility companies and VDOT prior to initiation of work.
- The contractor shall notify the local VDOT Land Development Office when work is to begin or cease for any undetermined length of time. VDOT requires and shall receive 48 hours advance notice prior to any required or requested inspection.
- The contractor shall notify the Traffic Operations Center at (540) 332-9500 for any traffic control plan that impacts a VDOT maintained Interstate or Primary roadway to provide notification of the installation and removal of the work zone.
- The contractor shall be responsible for maintaining a VDOT permitted temporary construction entrance(s) in accordance with Section 3.02 of the Virginia Erosion and Sediment Control Handbook. Furthermore, access to other properties affected by this project shall be maintained through construction.
- Contractor shall ensure adequate drainage is achieved and maintained on the site during and at the end of construction.
- All water and sewer lines within existing or proposed VDOT right-of-way shall have a minimum thirty-six (36) inches cover and when possible shall be installed under roadway drainage facilities at conflict points.
- Any unusual subsurface conditions (e.g., unsuitable soils, springs, sinkholes, voids, caves, etc.) encountered during the course of construction shall be immediately brought to the attention of the engineer and VDOT. Work shall cease in that vicinity until an adequate design can be determined by the engineer and approved by VDOT.
- All fill areas, borrow material and undercut areas shall be inspected and approved by a VDOT representative prior to placement of fill. A VDOT representative shall be present to insure the soil sample(s) obtained for CBR's is representative of the location. When soil samples are submitted to private laboratories for testing, the samples shall be clearly identified and labeled as belonging to a project to be accepted by VDOT and that testing shall be performed in accordance with all applicable VDOT standards and procedures.
- All roadway fill, base, subgrade material, and backfill in utility/storm sewer trenches shall be in accordance with the lift thicknesses, density and moisture requirements as specified in the current VDOT Road and Bridge Specifications. Certified copies of test reports shall be submitted to VDOT daily, unless specified otherwise.
- VDOT Standard CD and UD underdrains shall be installed where indicated on these plans and/or as specified by VDOT.
- A post installation visual/video camera inspection shall be conducted by the Contractor on all pipes identified on the plans as storm sewer pipe and a select number of pipe culverts. For pipe culverts, minimum of one pipe installation for each size of each material type will be inspected or ten percent of the total amount for each size and material type summarized. All pipe installations on the plans not identified as storm sewer pipe shall be considered as culvert pipe for inspection purposes. Additional testing may be required as directed by the Area and Use Engineer or their representative.
- The installation of any entrances and mailboxes within any dedicated street right-of-way shall meet VDOT minimum design standards and is the responsibility of the developer.
- Prior to VDOT acceptance of any streets, all required street signage and/or pavement markings shall be installed by the developer in accordance with the Manual On Uniform Traffic Control Devices.
- The developer shall provide the VDOT Land Development Office with a list of all material sources prior to the start of construction. Copies of all invoices for materials utilized within any dedicated street right-of-way must be provided to the local VDOT Land Development Office prior to acceptance of the work. Unit and total prices may be obscured.
- Aggregate base and subbase materials shall be placed on subgrade by means of a mechanical spreader. Density will be determined using the density control strip in accordance with Section 304 of the VDOT Road and Bridge Specifications and VTM-10. A certified compaction technician shall perform these tests. Certified copies of test reports shall be submitted to VDOT daily, unless specified otherwise. In addition to checking stone depths, a VDOT representative shall be notified and given the opportunity to be present during the construction and testing of the density control strip.
- Asphalt concrete pavements shall be placed in accordance with Section 315 of the VDOT Road and Bridge Specifications. Density shall be determined using the density control strip as specified in Section 315 and VTM-76. A certified compaction technician shall perform these tests. Certified copies of test reports shall be submitted to VDOT daily, unless specified otherwise. A VDOT representative shall be notified and given the opportunity to be present during the construction and testing of the control strip.
- In accordance with Section 302.03, the foundations for pipe culverts thirty-six (36) inches and larger shall be explored below the bottom of the excavation to determine the type and condition of the foundation. The contractor shall report findings of foundation exploration to the engineer and VDOT for approval prior to placing pipe. Foundation designs shall comply with VDOT Road and Bridge Standard PB-1. Where soft, yielding, or otherwise unsuitable foundation is encountered, the foundation design and/or need for foundation stabilization shall be determined by the engineer and approved by VDOT.
- VDOT Standard Guardrail shall be installed where warranted and/or as proposed on these plans in accordance with VDOT's installation criteria. Final approval of the guardrail layout to be given by VDOT after grading is mostly complete.
- Approval of these plans shall expire five (5) years from the date of the approval letter.
- VDOT Standard CG-12 Curb Ramps shall be installed where indicated on these plans and/or as specified by VDOT.
- The foundations for all box culverts shall be investigated by means of exploratory borings advanced below proposed foundation elevation to determine the type and condition of the foundation. The contractor shall submit copies of borehole logs and report findings of foundation exploration to the engineer and VDOT for approval prior to constructing box. Foundation designs shall comply with VDOT Road and Bridge Standard PB-1. Contrary to the Standard where rock is encountered and cast-in-place box is proposed, the thickness of bedding shall be six (6) inches. Where soft, yielding, or otherwise unsuitable foundation is encountered, the foundation design and/or need for foundation stabilization shall be determined by the engineer and approved by VDOT.

TRIP GENERATION DATA

| CLASS | USE | DWELLING UNITS | TRIP RATE | VPD |
|--------------------|-----------|----------------|-----------|--------|
| 230
(Section 2) | TOWNHOUSE | 17 | 8.145 | 138.46 |

* TAKEN FROM ITE TRIP GENERATION 9TH EDITION

PROJECT NOTES

- FREDERICK WATER CONSTRUCTION NOTES**
- The Authority's Water and Sewer Standards and Specifications are available at www.frederickwater.com.
 - The contractor shall adhere to the Authority's standards and specifications in effect at the time of construction.
 - The contractor shall coordinate with and arrange for inspection by the Authority.
 - The contractor shall connect a new sewer line to an existing manhole by core drilling the manhole.
 - A new water (or forced sewer) main shall be connected to an existing main by a wet tap. The Authority shall furnish all needed material and make the tap. An Application for Wet Tap shall be submitted and the initial fee paid before tap is made.
 - Exact locations of water and sewer services on new lines are to be coordinated with the Authority's inspector.
 - The Authority's maintenance division shall furnish and install all water meters through 2 inch in size. It is the contractor's responsibility to have the meter box assembly installed correctly. Before a permanent meter is installed:
 - The meter box, with its frame and cover, must be properly aligned with the coppersetter.
 - The frame and cover shall be set to final grade.
 - The distance between the top of the cover and the coppersetter shall be between 18 and 21 inches.
 - All components of the meter box assembly shall be in proper working order.
 - For services that connect to existing lines:
 - The Authority shall furnish and install:
 - all 5/8"x3/4", 1", 1 1/2" and 2" water services
 - all sewer services.
 - The owner/developer shall:
 - coordinate (or have the contractor coordinate) the location of the service lateral with the Authority's engineering assistant
 - submit an Application for Service and pay the required fees.
 - All water service lines must have a backflow prevention assembly (double check valve or RPZ, as required). The assembly must meet ASSE standard number 1015 or 1013.
 - All fire lines must have a backflow prevention assembly (detector double check valve or RPZ, as required). The assembly shall meet ASSE standard number 1048 or 1047. Any exterior, privately owned fire line shall also have a fire service meter. The assembly shall be installed immediately before the backflow prevention unit. Radio read remotes are required.
 - The Authority shall review the mechanical plan(s) for design and material approval of a building's:
 - domestic water meter and its backflow prevention device, and/or its
 - fire service line's backflow prevention device.
 - DEQ must also approve sewer pump stations. FCSA requires a copy of DEQ's Certificate to Operate and a copy of the stations DEQ approved O&M Manual. These documents must be received before substantial completion is issued and water meters released.

OCT 2011

LEGEND

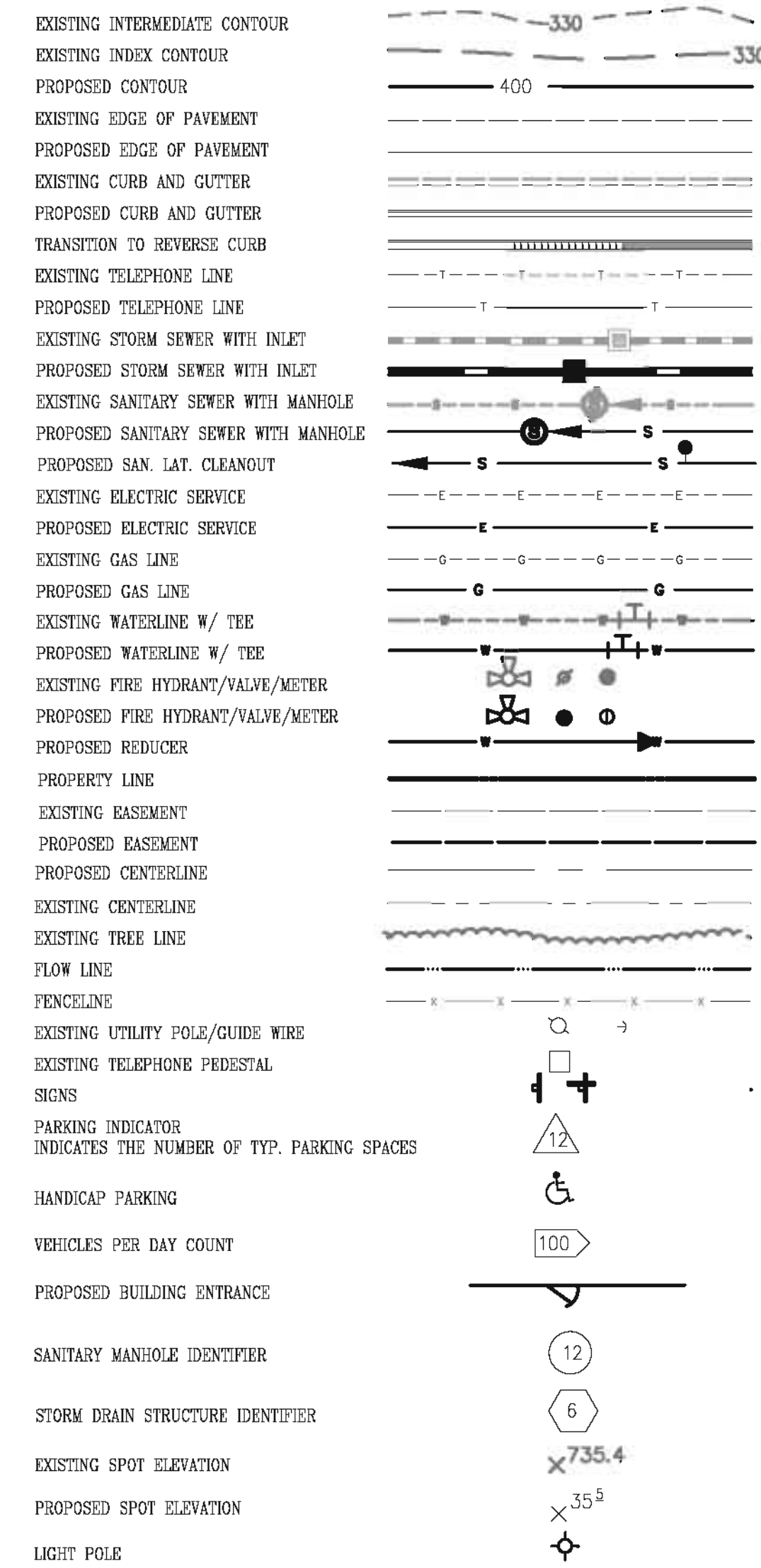

PROJECT INFORMATION

| | |
|---------------------------|--|
| PARCEL IDENTIFICATION NO. | 75-A-58 & 59 |
| STREET ADDRESS: | DOUBLE CHURCH RD. |
| PROJECT SITE AREA: | 1.9718 ACRES |
| DISTURBED AREA: | 1.9718 ACRES |
| CURRENT ZONING: | RP |
| CURRENT USE: | VACANT |
| PROPOSED USE: | RESIDENTIAL (TOWNHOUSES) |
| DWELLING DENSITY: | 17 UNITS/1.9718 ACRES = 8.62 UNIT PER ACRE |

| REQUIRED SETBACKS | REQUIRED SETBACKS FOR UNROOFED DECKS, STOOPS, LANDINGS: REQUIRED PROVIDED |
|--------------------|---|
| FRONT: 25' | FRONT: 15' 15' |
| REAR: 20' | REAR: 5' 5' |
| SIDE: 10' | SIDE: 5' 5' |
| PROVIDED SETBACKS: | |
| FRONT: 59.1' | |
| SIDE: 61.4' | |
| REAR: 43.8' | |

ANY FUTURE SIGNS SHALL BE IN CONFORMANCE WITH THE FREDERICK COUNTY ZONING ORDINANCE SECTION 165-201.06 SIGNS & SECTION.

ALL SIGNS REQUIRE A SEPARATE BUILDING PERMIT.

| | |
|--------------------------|---|
| SIGN SETBACK: | FRONT: 10' |
| | REAR: 10' |
| | SIDE: 10' |
| SUBDIVISION SIGN AREA: | 32 sf MAX. |
| SUBDIVISION SIGN HEIGHT: | 6' MAX. |
| PARKING REQUIRED: | 2 PER UNIT - 17 UNITS * 2 = 34 SPACES |
| PARKING PROVIDED: | 51 SPACES (17 GARAGE + 2 SPACES PER UNIT) |

OPEN SPACE CALCULATIONS: REQUIRED: 30% = 0.59 ACRES OR 25,700 SF PROVIDED: 42% = 0.82 ACRES OR 35,719 SF

DUMPSTER: NO DUMPSTER IS PROPOSED WITH THIS PLAN
MDP WAIVER APPROVAL DATE: JULY 10, 2017

FREDERICK WATER PROJECT INFORMATION

| WATER AND SANITARY SEWER USAGE | Calculation of demand/discharge WATER DEMAND |
|------------------------------------|--|
| WATER DEMAND 3,995 GPD | *Residential: 235 gpd per connection |
| SANITARY SEWER DISCHARGE 3,995 GPD | *Commercial: 76 gpd per 1,000 sf |
| | *Industrial: 25 gpd @ 10 persons per acre |
| | SEWER DISCHARGE |
| | Sewer discharge equals water demand |

GENERAL NOTES AND LEGEND
LIBERTY CHASE - 17 LOT TOWNHOUSE
T.M. #75-A-58, 59
OPEQUON MAGISTERIAL DISTRICT
FREDERICK COUNTY, VIRGINIA

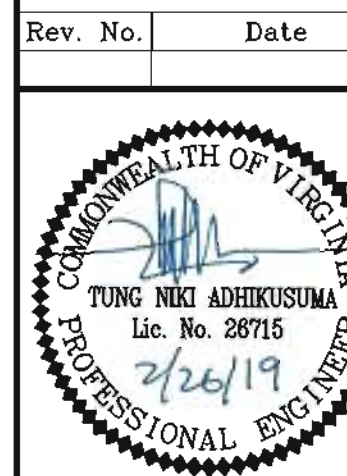

DATE: 2-15-2019

SCALE: N/A

DESIGNED BY: JNT

FILE NO. 4634T

SHEET 2 OF 14

15-19

161 Windy Hill Lane
Winchester, Virginia 22602
Telephone: (540) 682-4185
Fax: (540) 722-8528
www.greenwayeng.com



PROUDLY SERVING VIRGINIA & WEST VIRGINIA
OFFICES IN WINCHESTER, VA & MARTINSBURG, WV

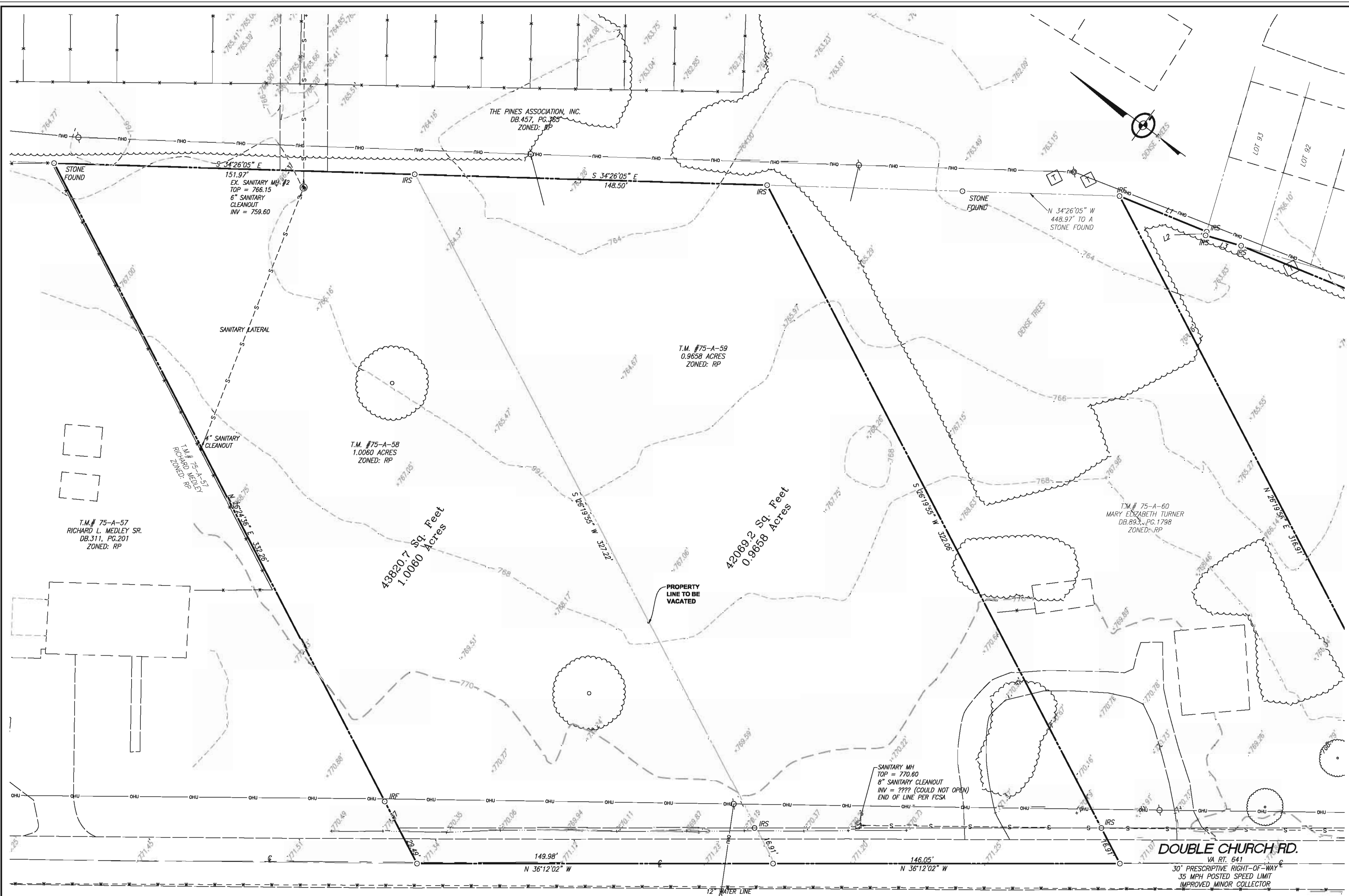

151 Windy Hill Lane
 Winchester, Virginia 22602
 Telephone: (540) 662-4185
 Fax: (540) 722-9526
 www.greenwayeng.com



PROFUSLY SERVING VIRGINIA & WEST VIRGINIA
 OFFICES IN WINCHESTER, VA & MARTINSBURG, WV

BOUNDARY AND EXISTING TOPO
LIBERTY CHASE - 17 LOT TOWNHOUSE
 T.M. #75-A-58, 59
 OPEQUON MAGISTERIAL DISTRICT
 FREDERICK COUNTY, VIRGINIA

| Rev. No. | Date |
|----------|------|
| | |



SURVEY AND TOPOGRAPHIC INFORMATION

- Boundary survey was performed by: GREENWAY ENGINEERING, INC. Dated: 07/28/2015
- Aerial, horizontal and vertical control surveys were performed by: GREENWAY ENGINEERING, INC. 07/28/2015 Date
- Aerial topographic mapping performed by: _____ Dated: _____

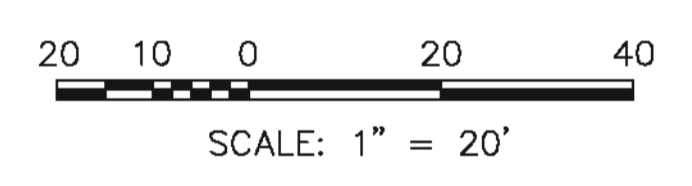

REETOWN RESIDENTIAL LOTS - 17 UNIT TOWNHOUSES EROSION AND SEDIMENT CONTROL NARRATIVE

Description: The Project development will consist of construction of 2 Multiplex Buildings (17 units) with related utilities and parking lot construction. The property is zoned RP and is located north of Double Church Road approximately 0.17 miles south of route 277 (Fairfax Pike) in Frederick County Virginia. Total site area for 1.9 acres of which approximately 1.9 acres will be disturbed for construction.

Date of construction: Construction will begin following plan approval and will take approximately twelve (6) months to complete.

Existing site conditions: The proposed site is vacant land. The site has one drainage area as indicated on the plans. The site drains northward to the back corner of the property. The property slopes on average between 2% and 4.5%.

Adjacent areas: The site is bounded on the east and west by single family homes, on the north by townhouses and on the south by Double Church Road.

Offsite areas: No offsite land will be disturbed.

Soils: The existing soil conditions were obtained from the USDA Soils Survey. The soils on this site consist of Blairton silt loam (3B) with a moderate erosion hazard.

Critical areas: There are no critical areas on this site.

Erosion And Sediment Control Measures: Unless otherwise indicated, all vegetative and structural erosion and sediment control measures shall be constructed and maintained according to the minimum standards and specifications of the Virginia erosion and sediment control handbook.

Structural Measures:

Phase I:

Install Temporary Construction Entrance with Wash Rack (3.02) at the entrance to the site on Ellison Drive (Section 7) to minimize sediment carried onto roadway.

Install silt fence (3.05) as shown on the plans to intercept and detain small amounts of sediment from disturbed areas during construction in order to prevent sediment from leaving the site.

Install temporary diversion dikes (3.09) as shown on the plans to divert sediment-laden runoff to the sediment trapping structures and to divert runoff to Sediment Traps.

Install temporary sediment traps (3.13) as shown on plan as a Phase 1 control measures prior to clearing the site. Traps shall detain runoff long enough to allow the majority of sediment to settle out prior to leaving the site.

Temporary seeding (3.31) and/or permanent seeding (3.32) shall be placed on all critical slopes (3:1 or greater) and as needed to stabilize disturbed areas.

Phase II:

Phase I controls shown on Phase II plan to remain for the duration of the project.

Nearing completion of the final road grade, storm sewer shall be installed. Inlet protection (3.07) shall be installed on all new inlets throughout the site.

Fill slope surface shall be left in a roughened condition to reduce erosion. Contractor shall redirect the concentrated flow away from the fill slope by installing diversion dike and divert the runoff to sediment traps or sediment basins.

Temporary seeding (3.31) and/or permanent seeding (3.32) shall be placed on all critical slopes (3:1 or greater) and as needed to stabilize disturbed areas.

Vegetative Measures:

Permanent or temporary soil stabilization shall be applied to denuded areas within seven (7) days after final grade is reached on any portion of the site. Temporary soil stabilization shall be applied within seven (7) days to denuded areas that may not be at final grade but will remain dormant for longer than fourteen (14) days. Permanent soil stabilization shall be applied to all areas that are to be left dormant for more than six (6) months.

Topsoil that has been stockpiled shall be surrounded with silt fence and protected by mulch and/or temporary vegetation immediately after grading.

All earth berms, diversions and sediment trap embankments are to be machine-compacted, seeded and mulched (hay mulch or straw) for temporary and/or permanent vegetative cover immediately after construction.

Erosion control mats shall be installed over steep (2:1) cut and fills slope which have been brought to final grade and seeded to protect from rill and gully erosion.

Management Strategies:

Construction shall be sequenced such that grading operations will begin and end as quickly as possible.

The site superintendent shall be responsible for the installation and maintenance of all erosion and sediment control measures. Maintenance of these measures throughout the project is critical to the effectiveness of the program.

After areas above controls have been stabilized, the controls shall be cleaned up and removed.

Electric power, telephone, storm, sanitary, water & gas supply trenches are to be compacted, seeded and mulched within five (5) days after backfilling. No more than 500 feet are to be open at any one time.

All cut and fill slopes are to be seeded and mulched within five (5) days of completion of grading.

Drainage swales shall be stabilized with check dams until vegetation has been well established, at which time the check dams shall be removed.

Devices listed above are considered minimum erosion and sediment controls. Additional control measures may be necessary due to contractor phasing or other unforeseen conditions. It is the contractor's responsibility to provide additional measures to those shown, as needed, in order to control erosion and contain sediment on site. All measures shall be installed according to the standards and specifications in the Virginia erosion and sediment control handbook.

Stormwater Management:

Increased runoff from this development will be controlled by an on site stormwater management facility.

Maintenance Program:

All control measures shall be inspected daily by the site superintendent or his representative and within 24 hours after any storm event greater than 0.5 inches of rain per 24-hour period. Any damaged structural measures are to be repaired by the end of the day. Seeded areas shall be checked regularly to ensure that a good stand of grass is maintained. All areas shall be fertilized and reseeded as needed until grass is established.

Trapped sediment is to be removed as required to maintain 50% trap efficiency and disposed of by spreading on site.

Inlet protection shall be checked regularly for sediment build-up. If the gravel outlet is clogged by sediment, it shall be removed and cleaned or replaced immediately.

The contractor is responsible for keeping existing public roads in a clean, dust and mud free, condition at all times.

Erosion and sediment control program:

1. Hold pre-construction meeting on site with inspector.
2. Install construction entrance.
3. Clearing and grubbing for sediment control devices only (Phase I sediment traps, diversion dikes and silt fence).
4. Placement of sediment control devices.
5. Obtain inspector's approval prior to beginning grading operations.
6. Clear and grub remainder of site.
7. Rough grade site.
8. Install drainage devices with sediment control.
9. Final grading.
10. Restoration and stabilization of disturbed areas.
11. Remove erosion and sediment control measures with the approval of the inspector.

Note: The Frederick County Public Works and Engineering Department retain the right to add and/or modify these erosion and sediment control measures during the construction process, within reason, to ensure adequate protection to the public and the environment.

Seeding schedule (soil stabilization):

1. All permanent seeding shall be in accordance with section 3.32 of the VESCH.
2. Spread topsoil at a minimum depth of four (4) inches.
3. Incorporate pulverized agricultural limestone into the topsoil at a rate of 92 lbs. per 1,000 square feet (2 tons per acre).
4. Fertilize with 10-10-10 fertilizer at a rate of 23 lbs per 1,000 square feet (1,000 lbs per acre).
5. Seed all areas with a seed mix consisting of 67% Kentucky 31 Tall Fescue and 33% Red Top Clover.
6. Mulch all seeded areas with straw mulch applied at a rate of 3,500 lbs per acre anchored with cutback or emulsified asphalt applied at a rate of 200 gallons per acre.

Dust control:

1. Temporary seeding shall be applied to all disturbed areas subject to little or no construction traffic.
2. All haul roads and other heavy traffic routes shall be sprinkled with water until the surface is wet and repeated as needed to control dust.

RESPONSIBLE LAND DISTURBER

NAME: _____
 CERTIFICATION #: _____
 DATE: _____

THE RESPONSIBLE LAND DISTURBER IS THE PARTY RESPONSIBLE FOR CARRYING OUT THE LAND DISTURBING ACTIVITY AS SET FORTH IN THE PLANS.

| EROSION/SEDIMENT CONTROL LEGEND | | | |
|---|-----|--------|--|
| NO. | KEY | SYMBOL | DESCRIPTION |
| 3.17 | CC | | STORMWATER CONVEYANCE CHANNEL |
| 3.02 | CE | | TEMPORARY GRAVEL CONSTRUCTION ENTRANCE |
| 3.05 | SF | | SUPER SILT FENCE |
| 3.09 | DD | | TEMPORARY DIVERSION DIKE |
| 3.14 | SB | | TEMPORARY SEDIMENT TRAP |
| 3.18 | OP | | OUTLET PROTECTION |
| | LCG | | LIMITS OF CLEARING & GRADING |
| | | | DRAINAGE DIVIDES |
| ★ CRITICAL SLOPE - CRITICAL SLOPE TO BE SEEDED, MULCHED AND TACKED WITHIN 14 DAYS AFTER START OF GRADING, OR SOEDED AND PEGGED WITHIN 14 DAYS AFTER START | | | |

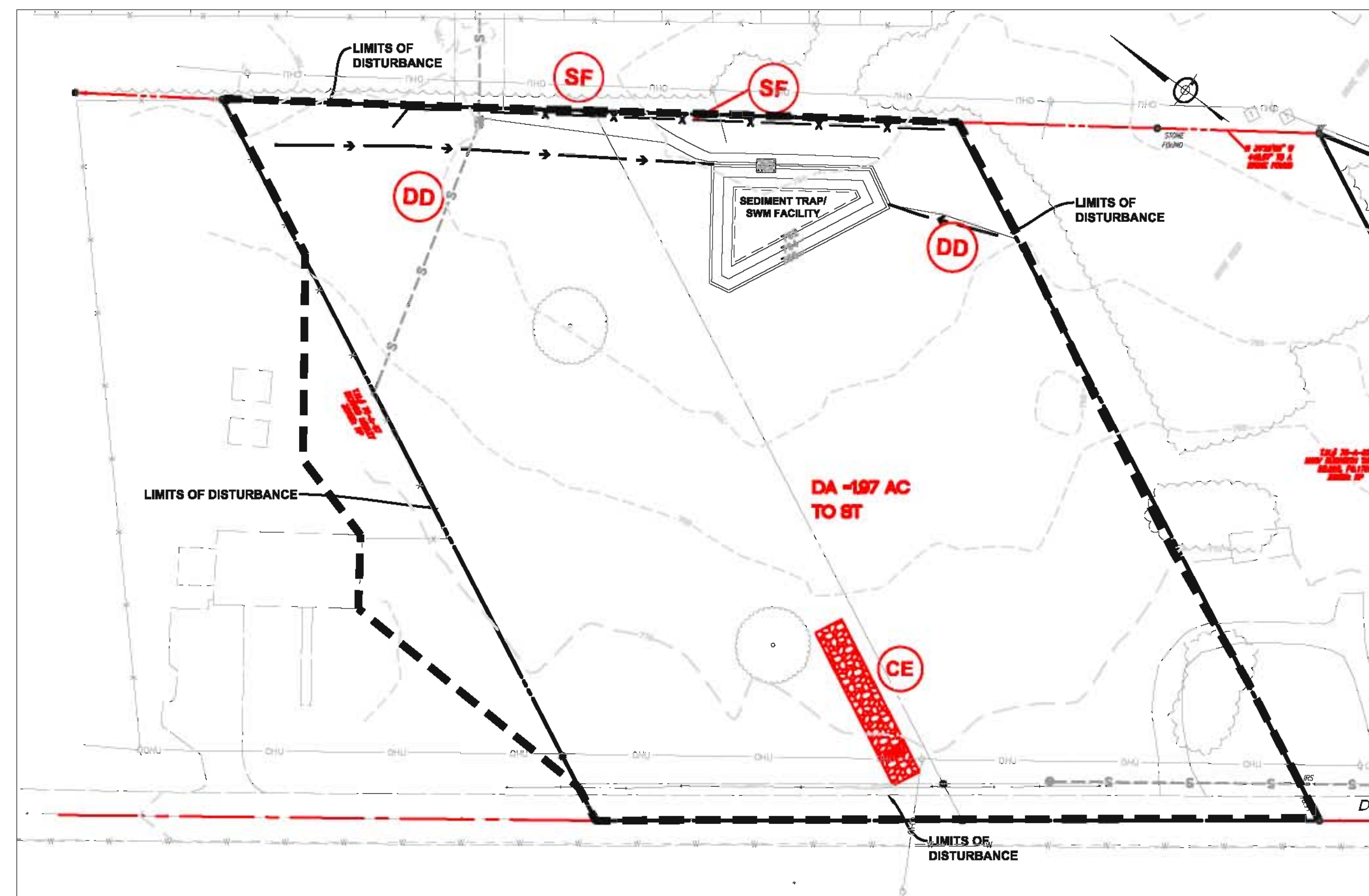

EROSION & SEDIMENT CONTROL PHASE I

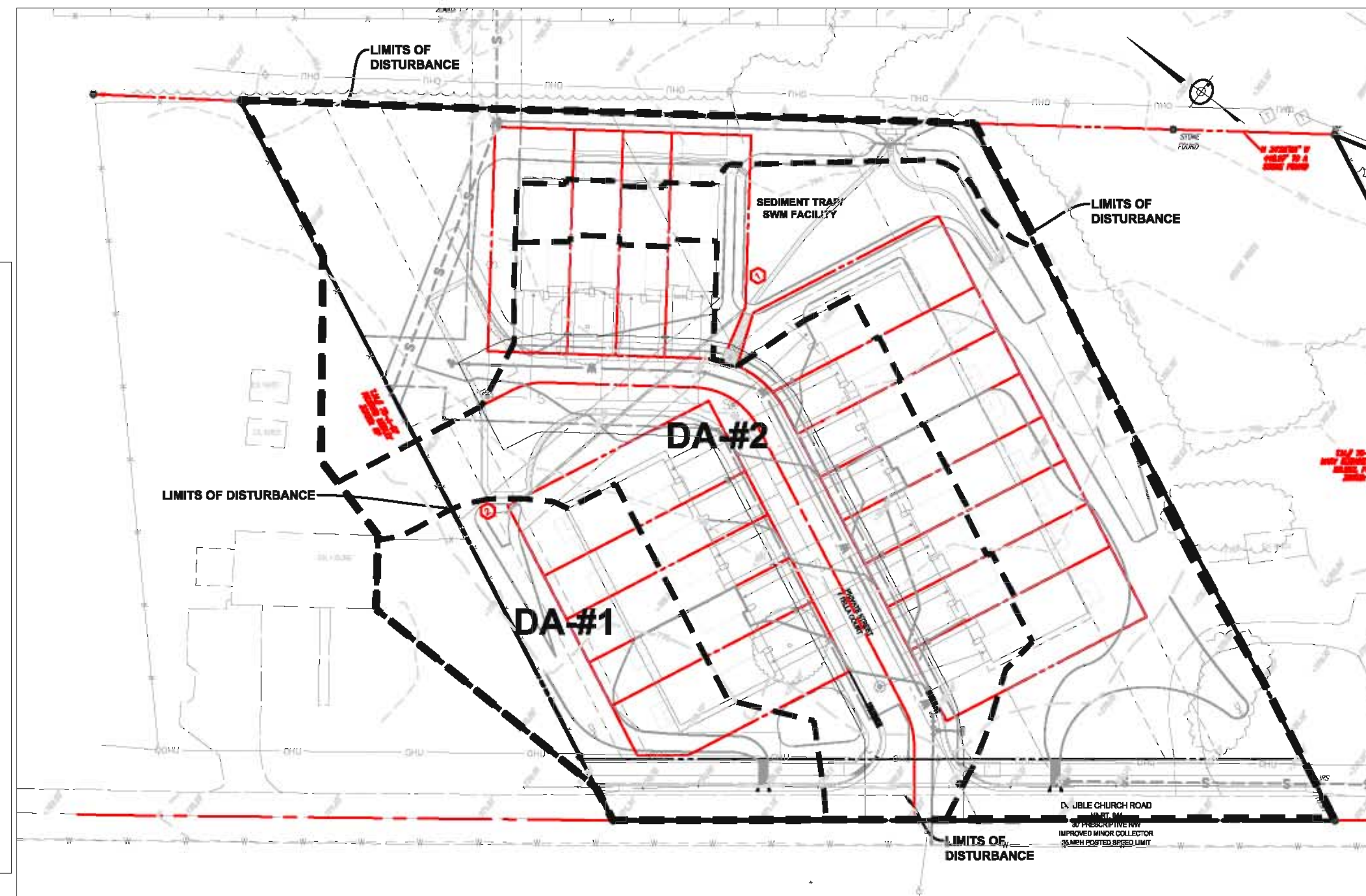

EROSION & SEDIMENT CONTROL PHASE II

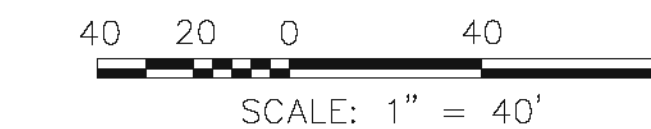

| SEDIMENT TRAP COMPUTATIONS | | | | | | | | | | | | |
|----------------------------|---------------|------------------|-------------|------------------|-------------|---------------|---------------|-------------------|-------------|-----------|-------------|-------------------|
| TRAP# | DRAINAGE AREA | STORAGE REQUIRED | | STORAGE PROVIDED | | OUTLET HEIGHT | STORAGE DEPTH | STORAGE DIMENSION | WEIR LENGTH | TOP WIDTH | BERM HEIGHT | ELEV. TOP OF WEIR |
| | | WET CU. YD. | DRY CU. YD. | WET CU. YD. | DRY CU. YD. | | | | | | | |
| 1 | 1.37AC | 120 | 120 | 150 | 130 | 1.0 | 3.5 | 67X32 | 8 | 2.0 | 2 | 564.5 |

151 Windy Hill Lane
 Winchester, Virginia 22602
 Telephone: (540) 662-4185
 Fax: (540) 722-8528
 www.greenwayeng.com

GREENWAY
 ENGINEERING

PROUDLY SERVING VIRGINIA & WEST VIRGINIA
 OFFICES IN WINCHESTER, VA & MARTINSBURG, WV

ER&S PHASE I & II
LIBERTY CHASE - 17 LOT TOWNHOUSE
 T.M. #75-A-58, 59
 OPEQUON MAGISTERIAL DISTRICT
 FREDERICK COUNTY, VIRGINIA

Rev. No. _____ Date _____

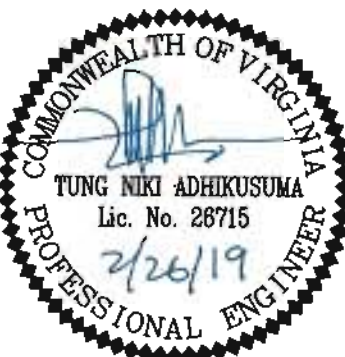

DATE: 2-15-2019

SCALE: 1" = 40'

DESIGNED BY: JNT

FILE NO. 4634T

SHEET 4 OF 14

15-19

MINIMUM CONSTRUCTION STANDARDS

An erosion and sediment control program adopted with this plan must be consistent with the vesch for 9VAC25-840-40 minimum standards:

- Permanent or temporary soil stabilization shall be applied to denuded areas within seven days after final grade is reached on any portion of the site. Temporary soil stabilization shall be applied within seven days to denuded areas that may not be at final grade but will remain dormant for longer than 14 days. Permanent stabilization shall be applied to areas that are to be left dormant for more than one year.
- During construction of the project, soil stock piles and borrow areas shall be stabilized or protected with sediment trapping measures. The applicant is responsible for the temporary protection and permanent stabilization of all soil stockpiles on site as well as borrow areas and soil intentionally transported from the project site.
- A permanent vegetative cover shall be established on denuded areas not otherwise permanently stabilized. Permanent vegetation shall not be considered established until a ground cover is achieved that is uniform, mature enough to survive and will inhibit erosion.
- Sediment basins and traps, perimeter dikes, sediment barriers and other measures intended to trap sediment shall be constructed as a first step in any land-disturbing activity and shall be made functional before upslope land disturbance takes place.
- Stabilization measures shall be applied to earthen structures such as dams, dikes and diversions immediately after installation.
- Sediment traps and sediment basins shall be designed and constructed based upon the total drainage area to be served by the trap or basin.
 - The minimum storage capacity of a sediment trap shall be 134 cubic yards per acre of drainage area and the trap shall only control drainage areas less than three acres.
 - Surface runoff from disturbed areas that is comprised of flow from drainage areas greater than or equal to three acres shall be controlled by a sediment basin. The minimum storage capacity of a sediment basin shall be 134 cubic yards per acre of drainage area. The outfall system shall, at a minimum, maintain the structural integrity of the basin during a 25-year storm of 24-hour duration. Runoff coefficients used in runoff calculations shall correspond to a bare earth condition or those conditions expected to exist while the sediment basin is utilized.
 - Cut and fill slopes shall be designed and constructed in a manner that will minimize erosion. Slopes that are found to be eroding excessively within one year of permanent stabilization shall be provided with additional slope stabilizing measures until the problem is corrected.
 - Concentrated runoff shall not flow down cut or fill slopes unless contained within an adequate temporary or permanent channel, flume or slope drain structure.
 - Whenever water seeps from a slope face, adequate drainage or other protection shall be provided.
 - All storm sewer inlets that are made operable during construction shall be protected so that sediment-laden water cannot enter the conveyance system without first being filtered or otherwise treated to remove sediment.
 - Before newly constructed stormwater conveyance channels or pipes are made operational, adequate outlet protection and any required temporary or permanent channel lining shall be installed in both the conveyance channel and receiving channel.
 - When work in a live watercourse is performed, precautions shall be taken to minimize erosion and sediment transport and to stabilize the work area to the greatest extent possible during construction. Nonerodible material shall be used for the construction of causeways and cofferdams. Earthen fill may be used for these structures if armored by nonerodible cover materials.
 - When a live watercourse must be crossed by construction vehicles more than twice in any six-month period, a temporary vehicular stream crossing constructed of nonerodible material shall be provided.
 - All applicable federal, state and local requirements pertaining to working in or crossing live watercourses shall be met.
 - The bed and banks of a watercourse shall be stabilized immediately after work in the watercourse is completed.
 - Underground utility lines shall be installed in accordance with the following standards in addition to other applicable criteria:
 - No more than 500 linear feet of trench may be opened at one time.
 - Excavated material shall be placed on the uphill side of trenches.
 - Effluent from dewatering operations shall be filtered or passed through an approved sediment trapping device, or both, and discharged in a manner that does not adversely affect flowing streams or off-site property.
 - Material used for backfilling trenches shall be properly compacted in order to minimize erosion and promote stabilization.
 - Restabilization shall be accomplished in accordance with this chapter.
 - Applicable safety requirements shall be complied with.
 - Where construction vehicle access routes intersect paved or public roads, provisions shall be made to minimize the transport of sediment by vehicular tracking onto the paved surface. Where sediment is transported onto a paved or public road surface, the road surface shall be cleaned thoroughly at the end of each day. Sediment shall be removed from the roads by shoveling or sweeping and transported to a sediment control disposal area. Street washing shall be allowed only after sediment is removed in this manner. This provision shall apply to individual development lots as well as to larger land-disturbing activities.
 - All temporary erosion and sediment control measures shall be removed within 30 days after final site stabilization or after the temporary measures are no longer needed, unless otherwise authorized by the VESCP authority. Trapped sediment and the disturbed soil areas resulting from the disposition of temporary measures shall be permanently stabilized to prevent further erosion and sedimentation.
 - Properties and waterways downstream from development sites shall be protected from sediment deposition, erosion and damage due to increases in volume, velocity and peak flow rate of stormwater runoff for the stated frequency storm of 24-hour duration in accordance with the following standards and criteria. Stream restoration and relocation projects that incorporate natural channel design concepts are not man-made channels and shall be exempt from any flow rate capacity and velocity requirements for natural or man-made channels.
 - Concentrated stormwater runoff leaving a development site shall be discharged directly into an adequate natural or man-made receiving channel, pipe or storm sewer system. For those sites where runoff is discharged into a pipe or pipe system, downstream stability analyses at the outfall of the pipe or pipe system shall be performed.
 - Adequacy of all channels and pipes shall be verified in the following manner:
 - The applicant shall demonstrate that the total drainage area to the point of analysis within the channel is one hundred times greater than the contributing drainage area of the project in question; or
 - (a) Natural channels shall be analyzed by the use of a two-year storm to verify that stormwater will not overtop channel banks nor cause erosion of channel bed or banks.
 - (b) All previously constructed man-made channels shall be analyzed by the use of a 10-year storm to verify that stormwater will not overtop its banks and by the use of a two-year storm to demonstrate that stormwater will not cause erosion of channel bed or banks; and
 - (c) Pipes and storm sewer systems shall be analyzed by the use of a

- If existing natural receiving channels or previously constructed man-made channels or pipes are not adequate, the applicant shall:
 - Improve the channels to a condition where a 10-year storm will not overtop the banks and a two-year storm will not cause erosion of the channel, the bed, or the banks; or
 - Improve the pipe or pipe system to a condition where the 10-year storm is contained within the appurtenances;
 - Develop a site design that will not cause the pre-development peak runoff rate from a two-year storm to increase when runoff outfalls into a natural channel or will not cause the pre-development peak runoff rate from a 10-year storm to increase when runoff outfalls into a man-made channel; or
 - Provide a combination of channel improvement, stormwater detention or other measures which is satisfactory to the VESCP authority to prevent downstream erosion.
- The applicant shall provide evidence of permission to make the improvements.
- All hydrologic analyses shall be based on the existing watershed characteristics and the ultimate development condition of the subject project.
- If the applicant chooses an option that includes stormwater detention, he shall obtain approval from the VESCP of a plan for maintenance of the detention facilities. The plan shall set forth the maintenance requirements of the facility and the person responsible for performing the maintenance.
- Outfall from a detention facility shall be discharged to a receiving channel, and energy dissipators shall be placed at the outfall of all detention facilities as necessary to provide a stabilized transition from the facility to the receiving channel.
- All on-site channels must be verified to be adequate.
- Increased volumes of sheet flows that may cause erosion or sedimentation on adjacent property shall be diverted to a stable outlet, adequate channel, pipe or pipe system, or to a detention facility.
- In applying these stormwater management criteria, individual lots or parcels in a residential, commercial or industrial development shall not be considered to be separate development projects. Instead, the development, as a whole, shall be considered to be a single development project. Hydrologic parameters that reflect the ultimate development condition shall be used in all engineering calculations.
- All measures used to protect properties and waterways shall be employed in a manner which minimizes impacts on the physical, chemical and biological integrity of rivers, streams and other waters of the state.
- Any plan approved prior to July 1, 2014, that provides for stormwater management that addresses any flow rate capacity and velocity requirements for natural or man-made channels shall satisfy the flow rate capacity and velocity requirements for natural or man-made channels if the practices are designed to (i) detain the water quality volume and to release it over 48 hours; (ii) detain and release over a 24-hour period the expected rainfall resulting from the one year, 24-hour storm; and (iii) reduce the allowable peak flow rate resulting from the 1.5, 2, and 10-year, 24-hour storms to a level that is less than or equal to the peak flow rate from the site assuming it was in a good forested condition, achieved through multiplication of the forested peak flow rate by a reduction factor that is equal to the runoff volume from the site when it was in a good forested condition divided by the runoff volume from the site in its proposed condition, and shall be exempt from any flow rate capacity and velocity requirements for natural or man-made channels as defined in any regulations promulgated pursuant to § 62.1-44.15.54 or 62.1-44.15.65 of the Act.
- For plans approved on and after July 1, 2014, the flow rate capacity and velocity requirements of § 62.1-44.15.52 A of the Act and this subsection shall be satisfied by compliance with water quantity requirements in the Stormwater Management Act (§ 62.1-44.15.24 et seq. of the Code of Virginia) and attendant regulations, unless such land-disturbing activities are in accordance with 9VAC25-870-48 of the Virginia Stormwater Management Program (VSM) Regulation or are exempt pursuant to subdivision C 7 of § 62.1-44.15.34 of the Act.
- Compliance with the water quantity minimum standards set out in 9VAC25-870-66 of the Virginia Stormwater Management Program (VSM) Regulation shall be deemed to satisfy the requirements of this subdivision 19.

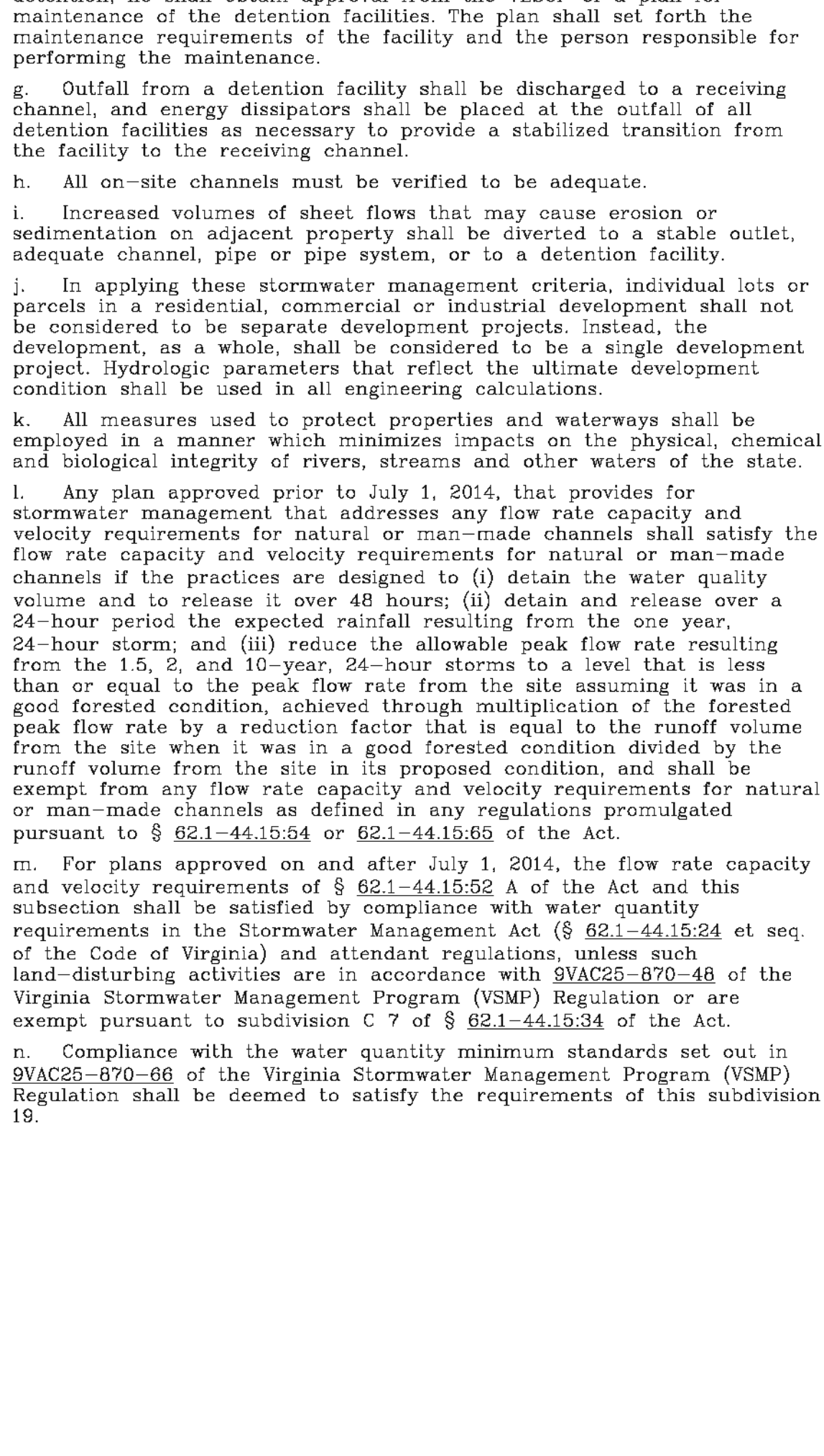

STONE CONSTRUCTION ENTRANCE

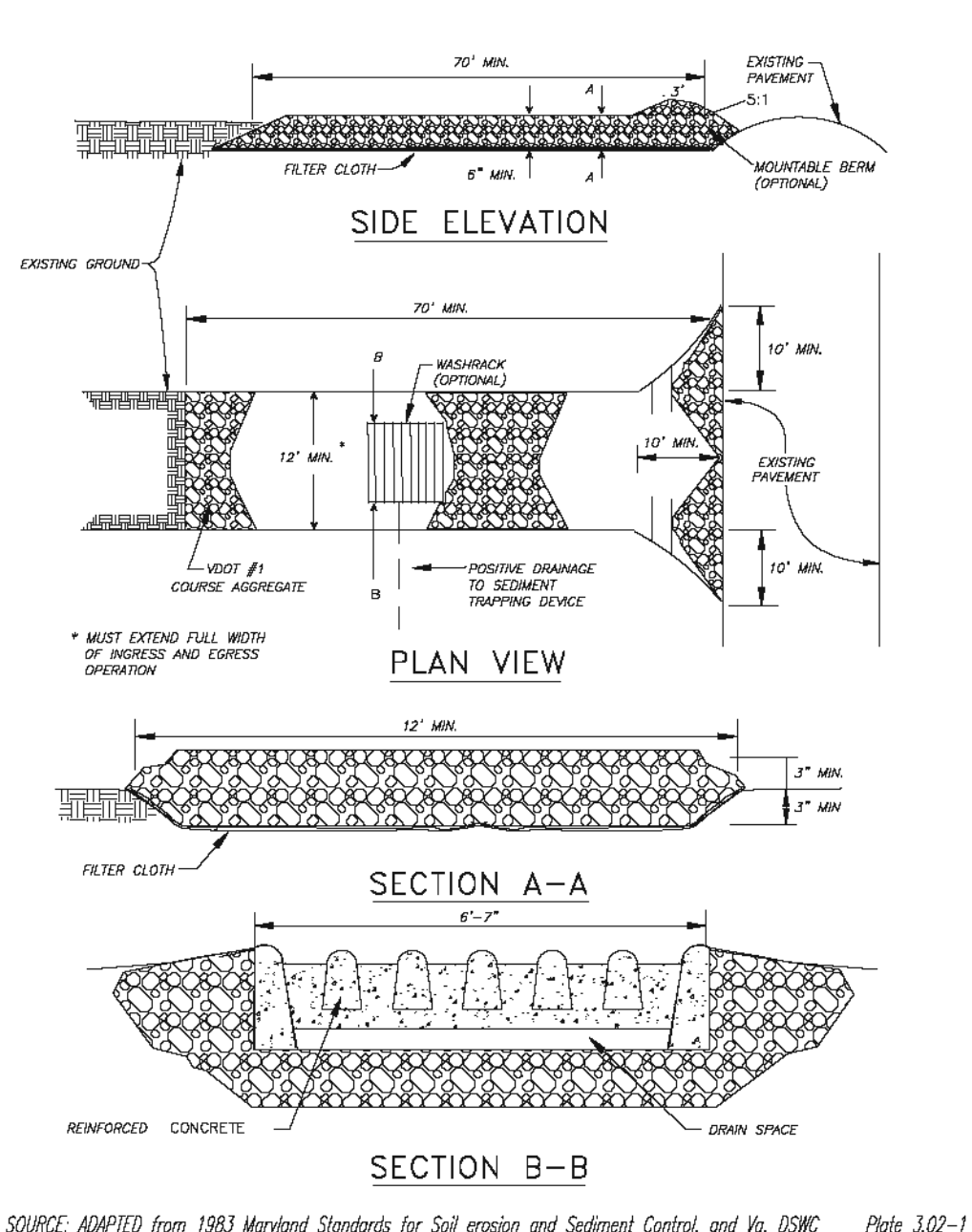

PIPE OUTLET CONDITIONS

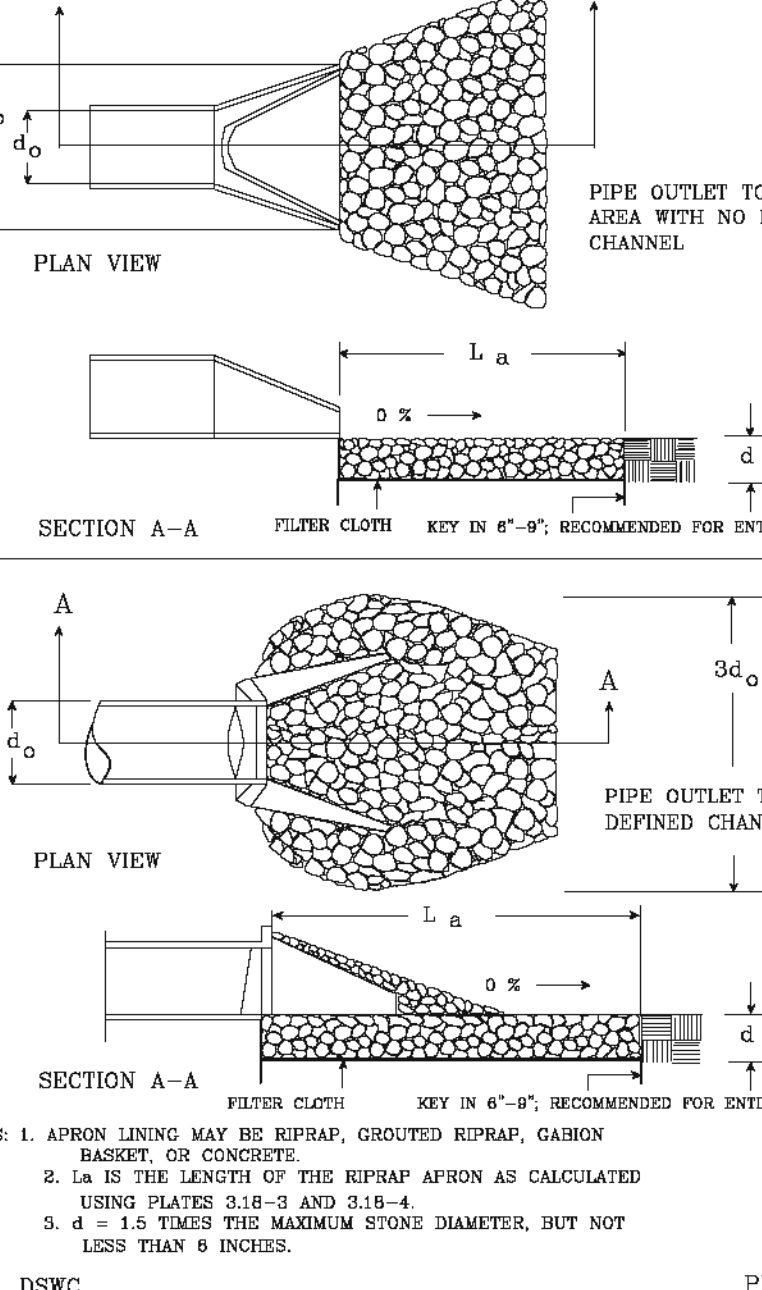

GRAVEL AND WIRE MESH DROP INLET SEDIMENT FILTER

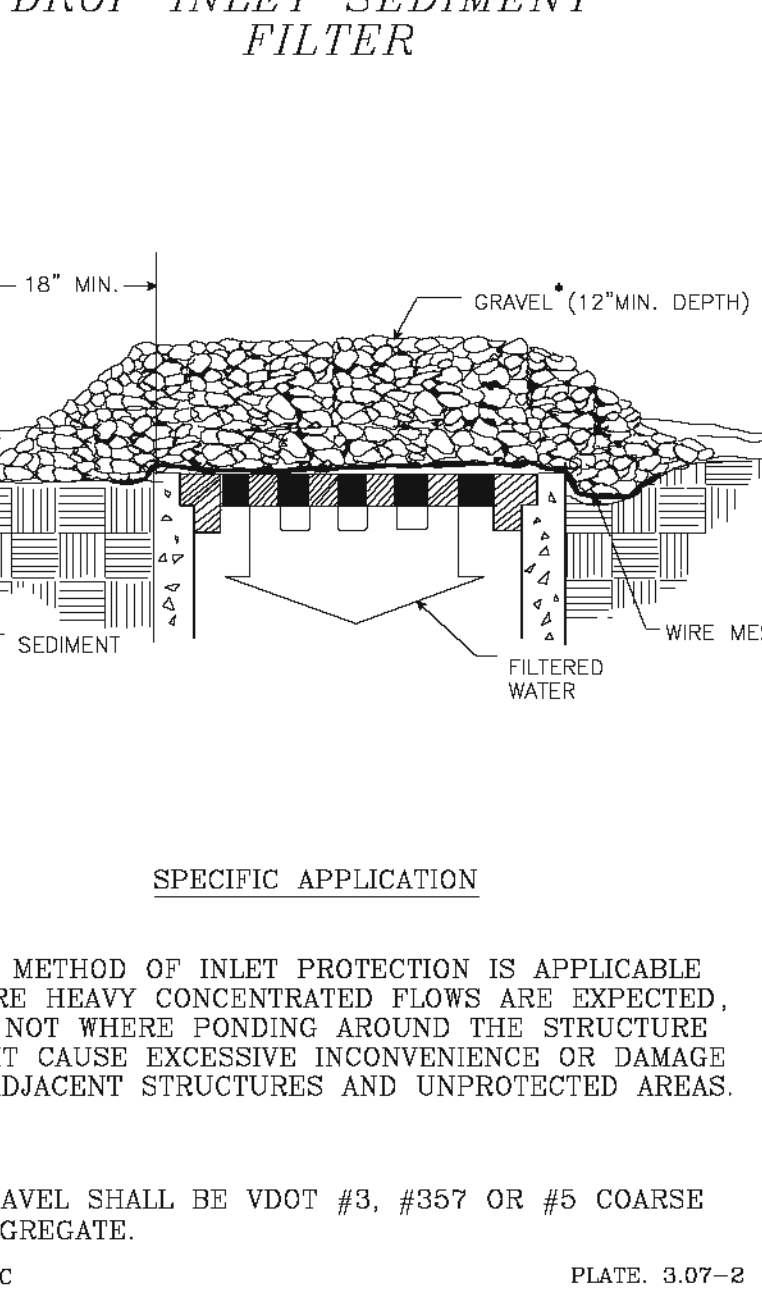

SUPER SILT FENCE

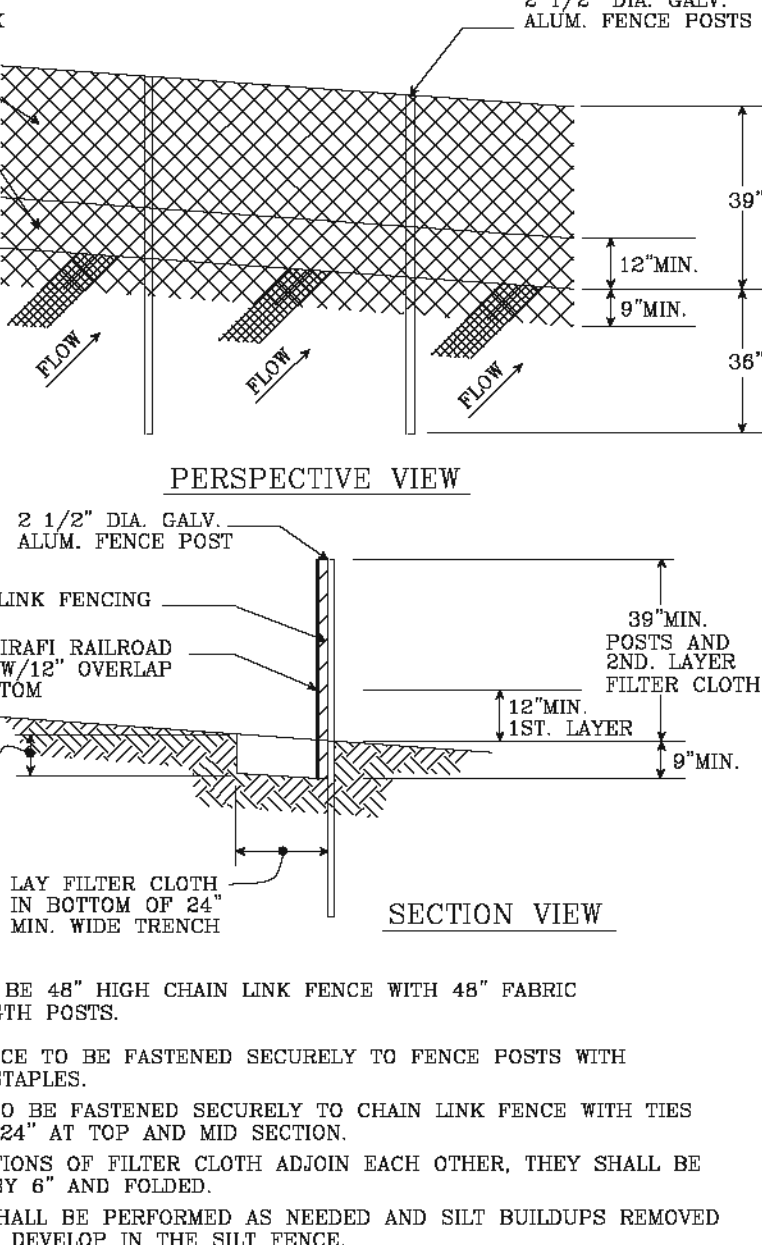

GRAVEL CURB INLET SEDIMENT FILTER

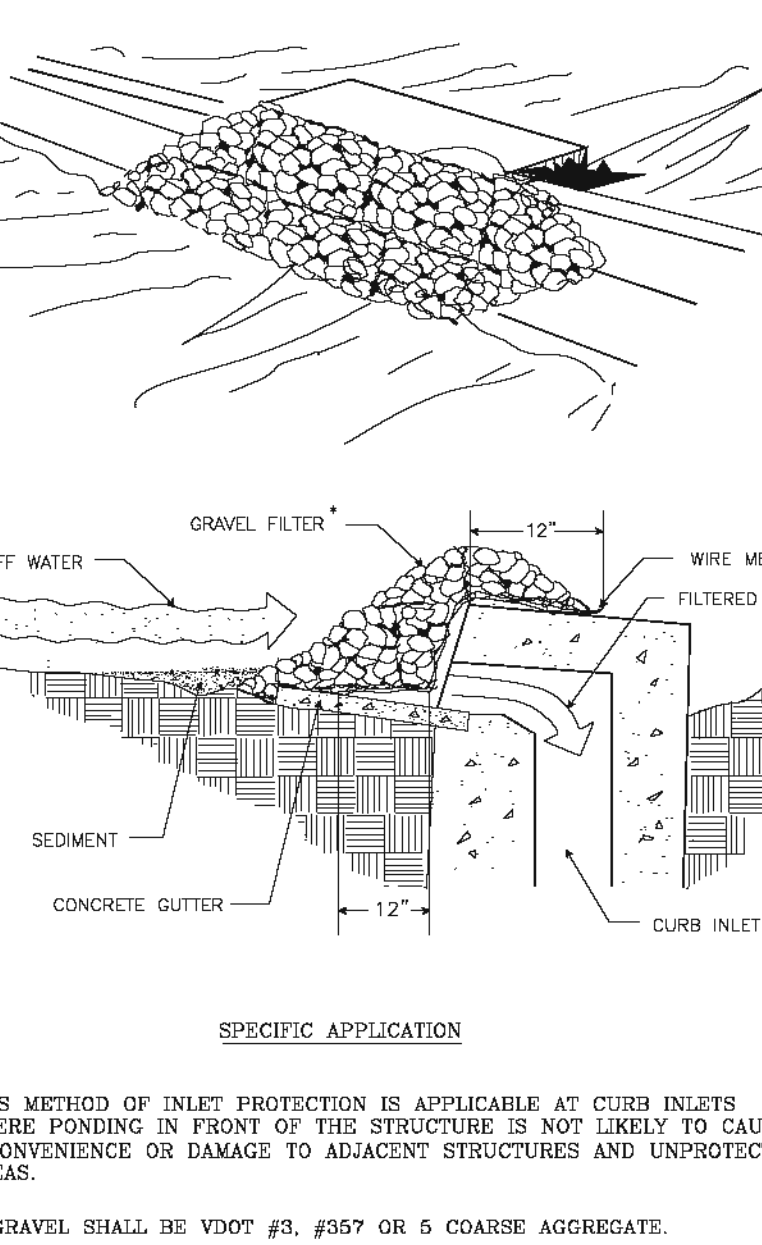

CONSTRUCTION OF A SILT FENCE (WITH WIRE SUPPORT)

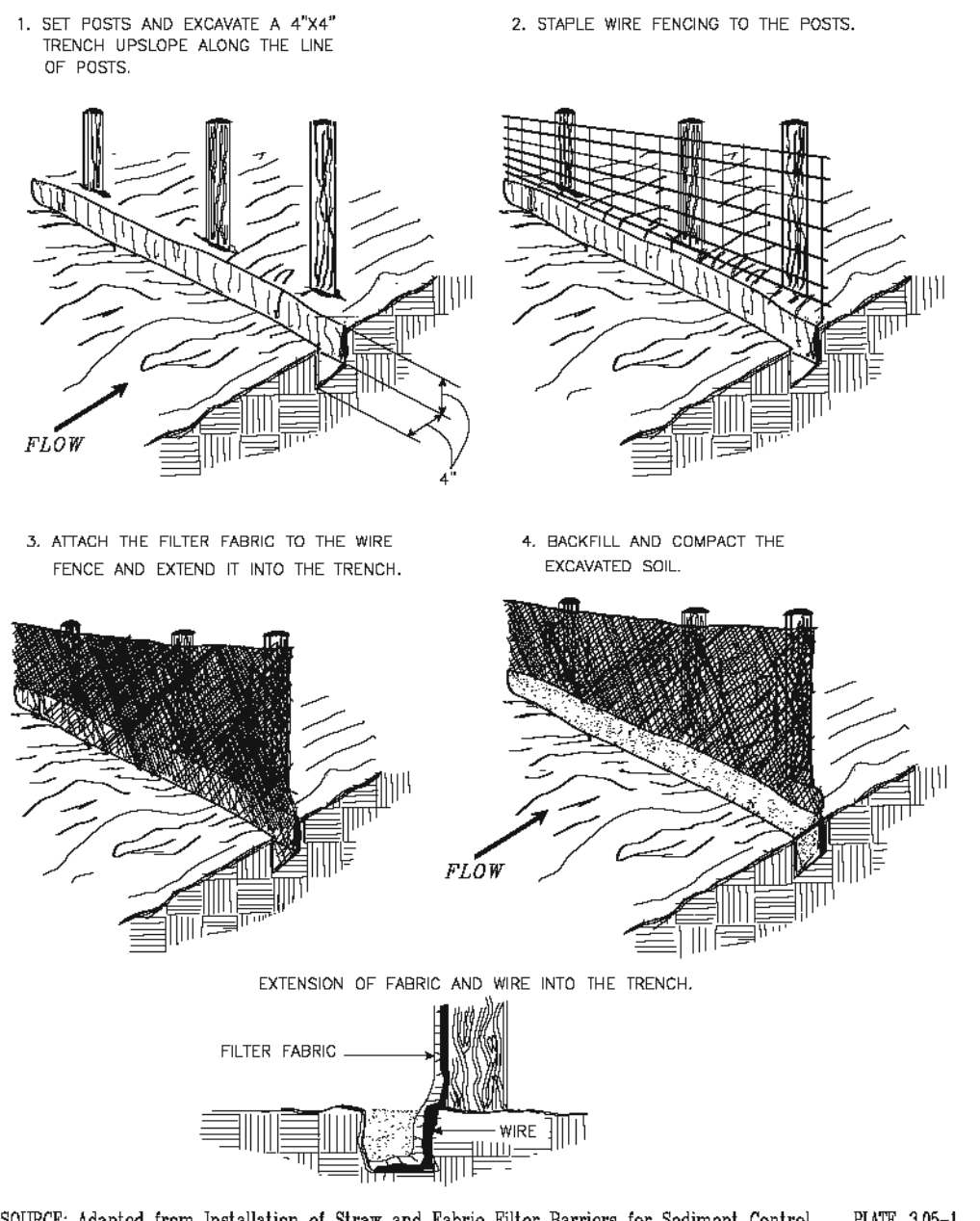

TEMPORARY DIVERSION DIKE

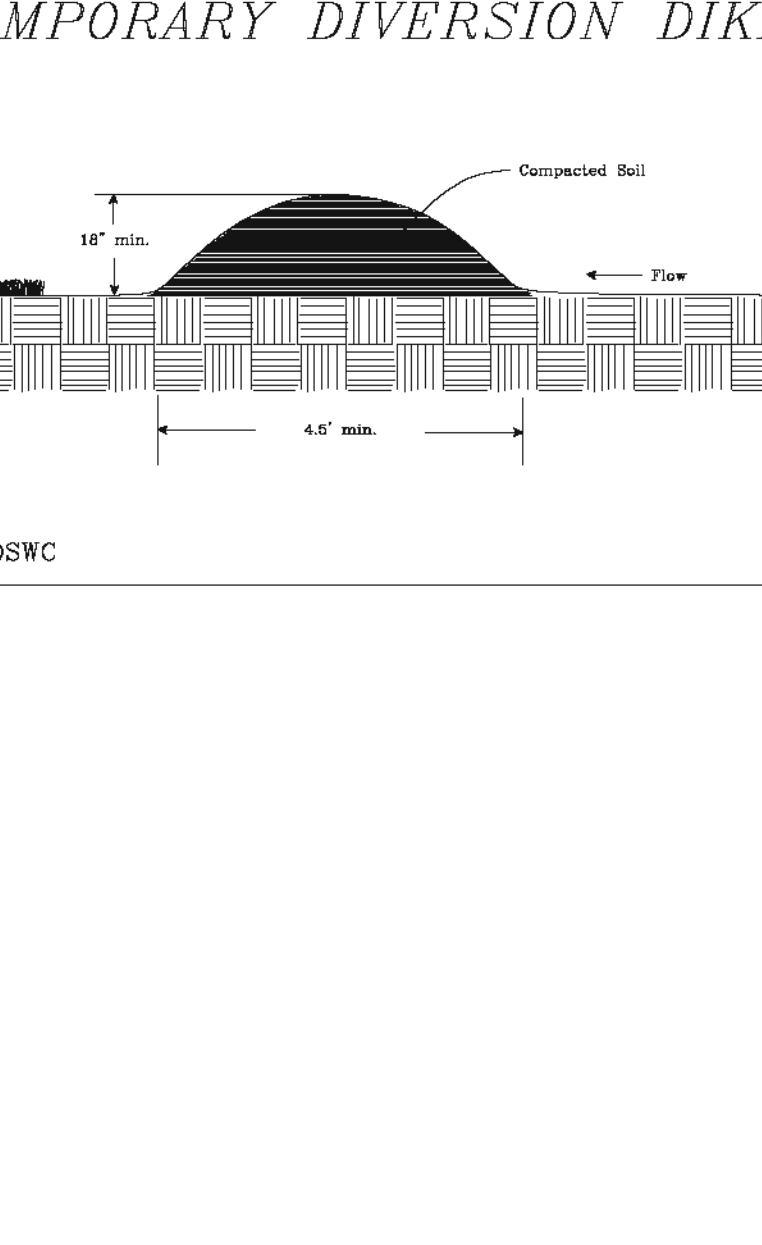

TEMPORARY SEDIMENT TRAP

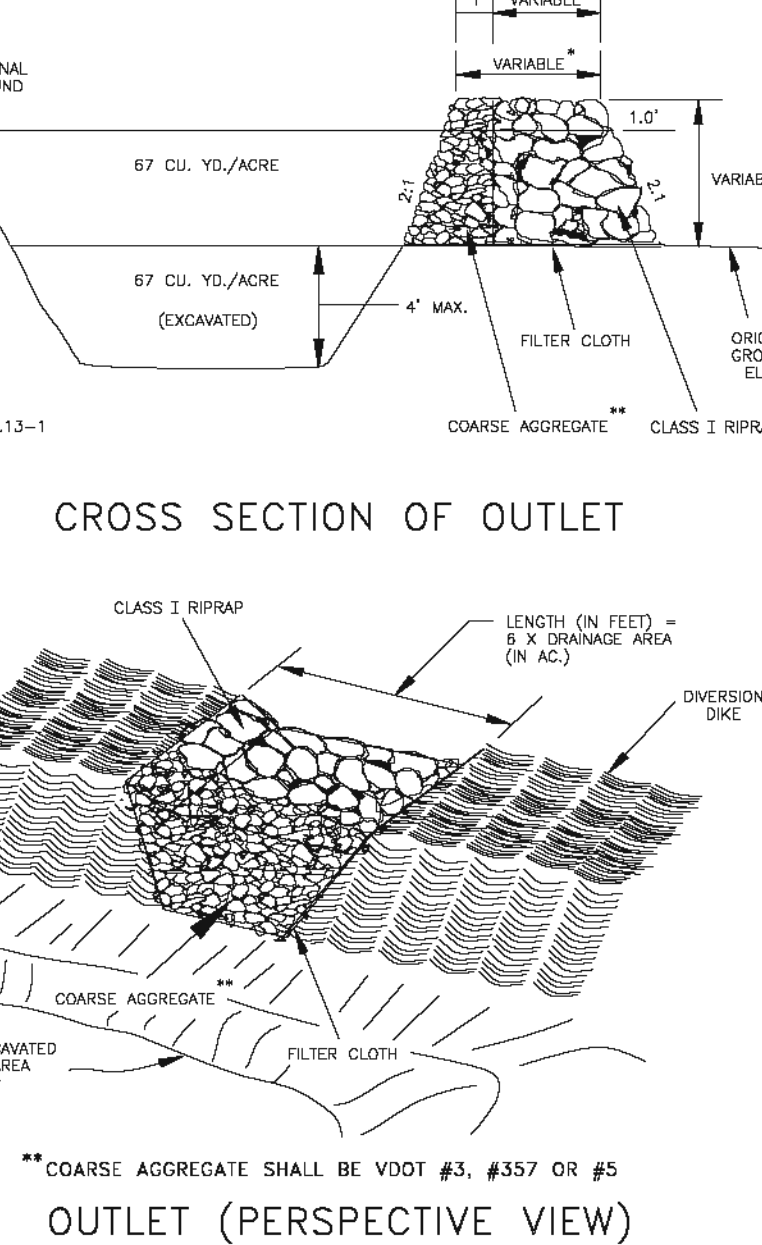

CROSS SECTION OF OUTLET

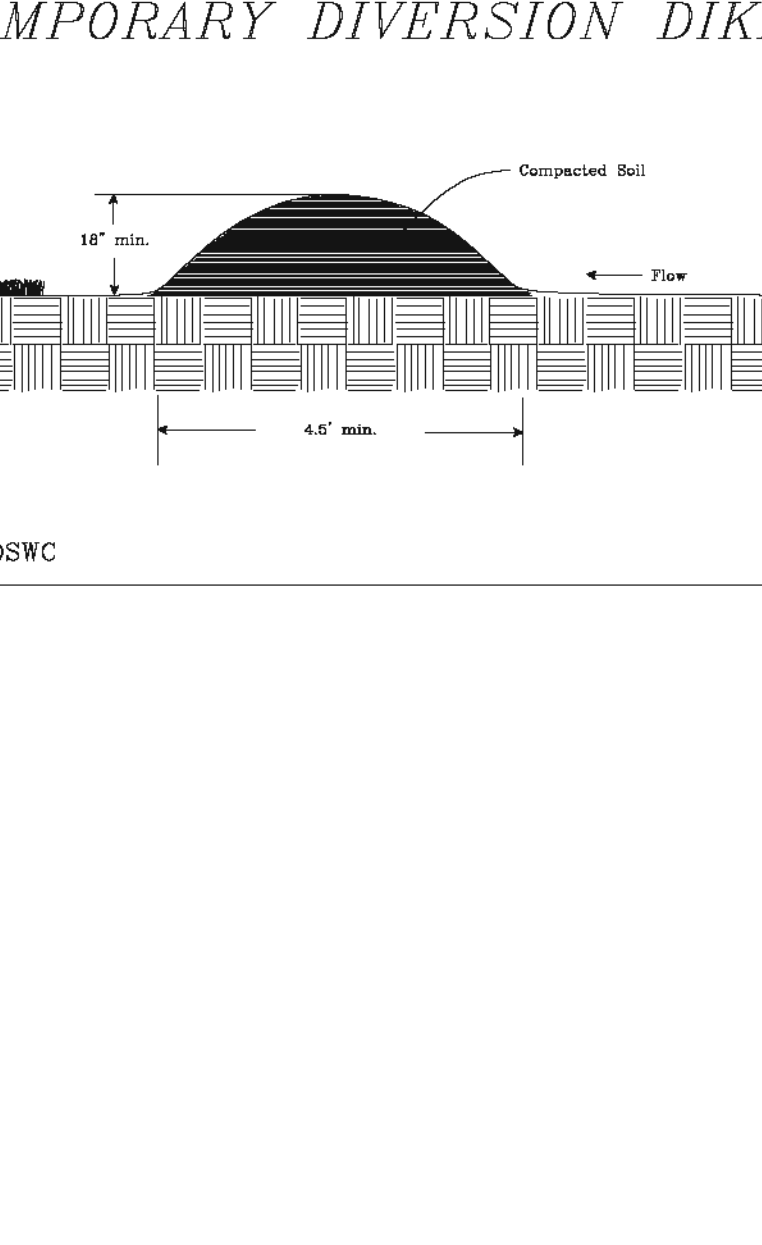

OUTLET (PERSPECTIVE VIEW)

TABLE 3.32-C
SITE SPECIFIC PERMANENT SEEDING MIXTURES FOR APPALACHIAN/MOUNTAIN AREA

| Minimum Care Lawn | Total Lbs. Per Acre |
|--|---------------------|
| - Commercial or Residential - Kentucky 31 or Turf-Type Tall Fescue | 200-250 lbs. |
| - Improved Perennial Ryegrass * | 90-100% |
| - Kentucky Bluegrass | 0-10% |
| - Kentucky Bluegrass | 0-10% |

High-Maintenance Lawn

| Minimum of three (3) up to five (5) varieties of bluegrass from approved list for use in Virginia. | 125 lbs. |
|--|----------|
| General Slope (3:1 or less) | |
| - Kentucky 31 Fescue | 128 lbs. |
| - Red Top Grass | 2 lbs. |
| - Seasonal Nurse Crop** | 20 lbs. |
| | 150 lbs. |
| Low-Maintenance Slope (Steeper than 3:1) | |
| - Kentucky 31 Fescue | 108 lbs. |
| - Red Top Grass | 2 lbs. |
| - Seasonal Nurse Crop** | 20 lbs. |
| - Crownvetch *** | 20 lbs. |
| | 150 lbs. |

* Perennial Ryegrass will germinate faster and at lower soil temperatures than fescue, thereby providing cover and erosion resistance for seedbed.

** Use seasonal nurse crop in accordance with seeding dates as stated below:

| Seeding Period | Annual Rye | Foxtail Millet | Annual Rye | Winter Rye |
|-------------------------------|------------|----------------|------------|------------|
| March, April through May 15th | Yes | Yes | Yes | Yes |
| May 15th through August 15th | Yes | Yes | Yes | Yes |
| August 15th through Sept. 1st | Yes | Yes | Yes | Yes |
| November through February | Yes | Yes | Yes | Yes |

*** If Flatpae is used, increase to 30 lbs./acre. All legume seed must be properly inoculated. Weeping Lovegrass may also be included in any slope or low-maintenance mixtures during warmer seeding periods; add 10-20 lbs./acre in mixes.

TABLE 3.31-B
ACCEPTABLE TEMPORARY SEEDING PLANT MATERIALS

"QUICK REFERENCE FOR ALL REGIONS"

| Planting Dates | Species | Rate (lbs./acre) |
|-------------------|--|------------------|
| Sept. 1 - Feb. 15 | 50/50 Mix of Annual Ryegrass (Lolium multi-florum) & Cereal (Winter) Rye (Secal cereale) | 50 - 100 |
| Feb. 16 - Apr. 30 | Annual Ryegrass (Lolium multi-florum) | 60 - 100 |
| May 1 - Aug. 31 | German Millet (Setaria italica) | 50 |

Seeding

Seed shall be evenly applied with a broadcast seeder, drill, cultipacker seeder or hydrosower. Small grains shall be planted no more than one inch deep. Grasses and legumes shall be planted with no less than 1/4" soil cover.

151 Windy Hill Lane
Winchester, Virginia 22602
Telephone: (540) 662-4185
Fax: (540) 722-8528
www.greenwayeng.com

GREENWAY ENGINEERING

PROUDLY SERVING VIRGINIA & WEST VIRGINIA
OFFICES IN WINCHESTER, VA & MARTINSBURG, WV

LIBERTY CHASE - 17 LOT TOWNHOUSE

E&S DETAILS

TM #75-A-58, 59

OPEQUON MAGISTERIAL DISTRICT
FREDERICK COUNTY, VIRGINIA

Rev. No. _____ Date _____

COMMONWEALTH OF VIRGINIA
TUNG NGI ADHIKUSUMA
Lic. No. 28715
2/26/19
PROFESSIONAL ENGINEER

DATE: 2-15-2019

SCALE: N/A

DESIGNED BY: JNT

FILE NO. 4634T

SHEET 5 OF 14

15-19

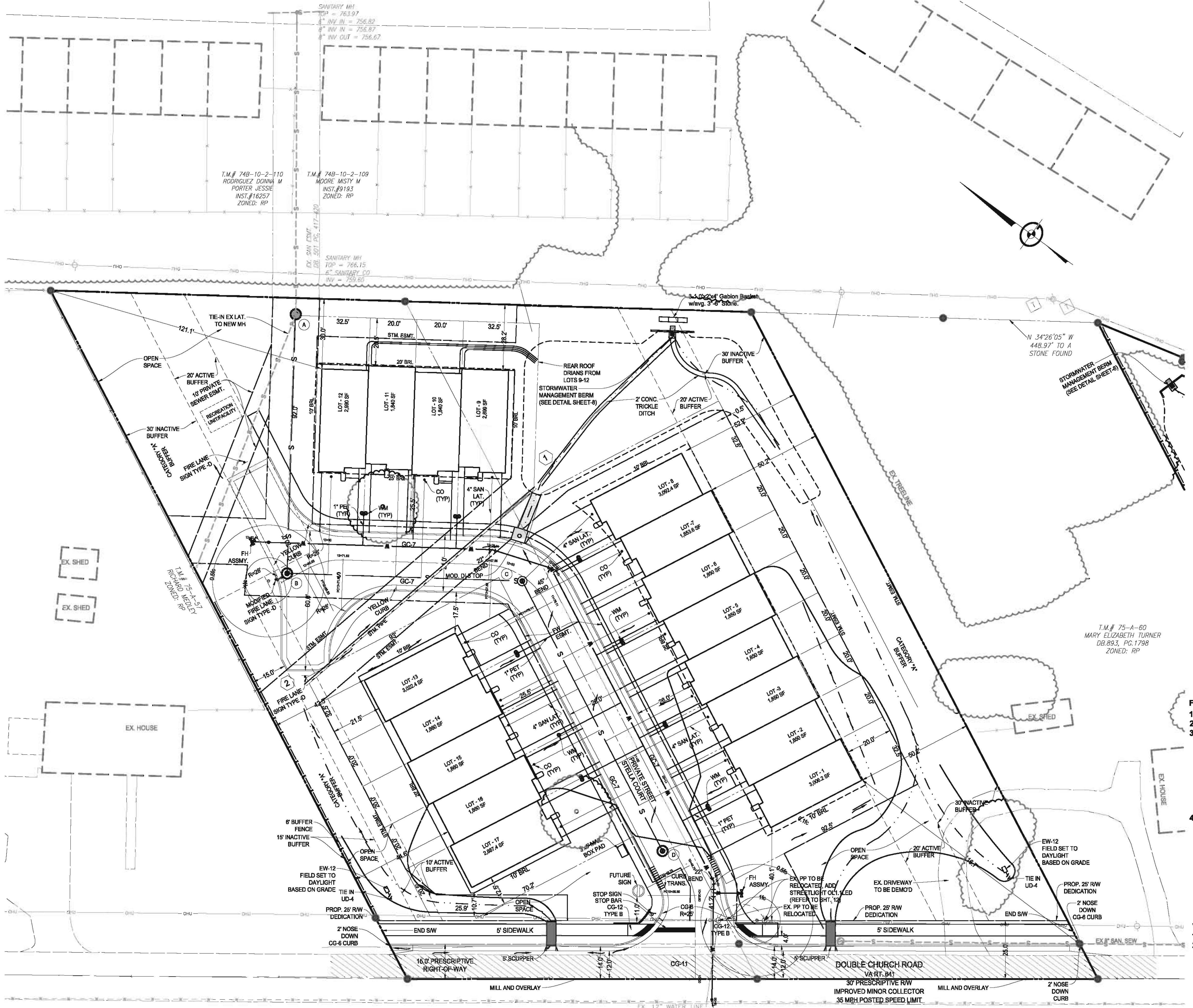

- Frederick Water NOTES:**
1. WATER LATERALS = 1" W/ 1/2" METERS.
 2. WATER METER REQUIRE TRAFFIC LIDS
 3. FREDERICK WATER HAS GRANTED A WAIVER TO THE MINIMUM PIPE DIAMETER FOR THE 130 +/- RUN OF EXISTING 6" SEWER MAIN DUE TO THE GRAVITY SLOPE IN THAT PIPE AND THE FACT THAT NO FURTHER EXPANSION BEYOND THE PROPOSED SITE PLAN IS CONCEIVABLE FOR THIS LINE DUE TO THE LOCATION OF OTHER FREDERICK WATER SEWER LINES ON DOUBLE CHURCH ROAD.
 4. NO OUTSIDE HVAC UNIT ETC. SHALL EXTEND OVER FREDERICK WATER EASEMENTS

- NOTES:**
1. 10X10 PATIOS SHOWN ARE PROPOSED W/ NO ROOF.
 2. DEVELOPER WILL SELECT RECREATION UNIT/FACILITIES AT THE TIME OF CONSTRUCTION. RECREATION UNIT SHALL BE EITHER OUTDOOR PAVILION, PLAYGROUND, TOT LOT, OR EQUIVALENT.
- 1 Recreation Unit required per 30 Dwellings Units:
17 Units/30= 0.58 Recreation Unit Req.

- VDOT NOTES**
1. UD-4 TO DAYLIGHT TO STD. EW-12
 2. CONTRACTOR TO COORDINATE LOCATION OF STOP BAR, PLACEMENT DETERMINED BY VDOT INSPECTOR

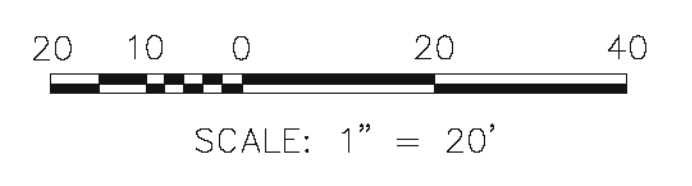

GEOMETRY PLAN

LIBERTY CHASE - 17 LOT TOWNHOUSE

TM #75-A-58, 59

OPEUON MAGISTERIAL DISTRICT
FREDERICK COUNTY, VIRGINIA

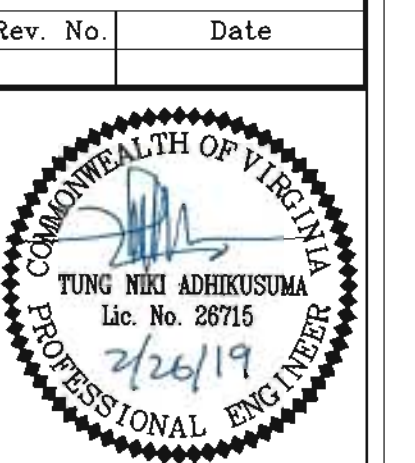

| | |
|--------------|-----------|
| Rev. No. | Date |
| | |
| DATE: | 2-15-2019 |
| SCALE: | 1" = 20' |
| DESIGNED BY: | JNT |
| FILE NO. | 4634T |
| SHEET | 6 OF 14 |
| 15-19 | |

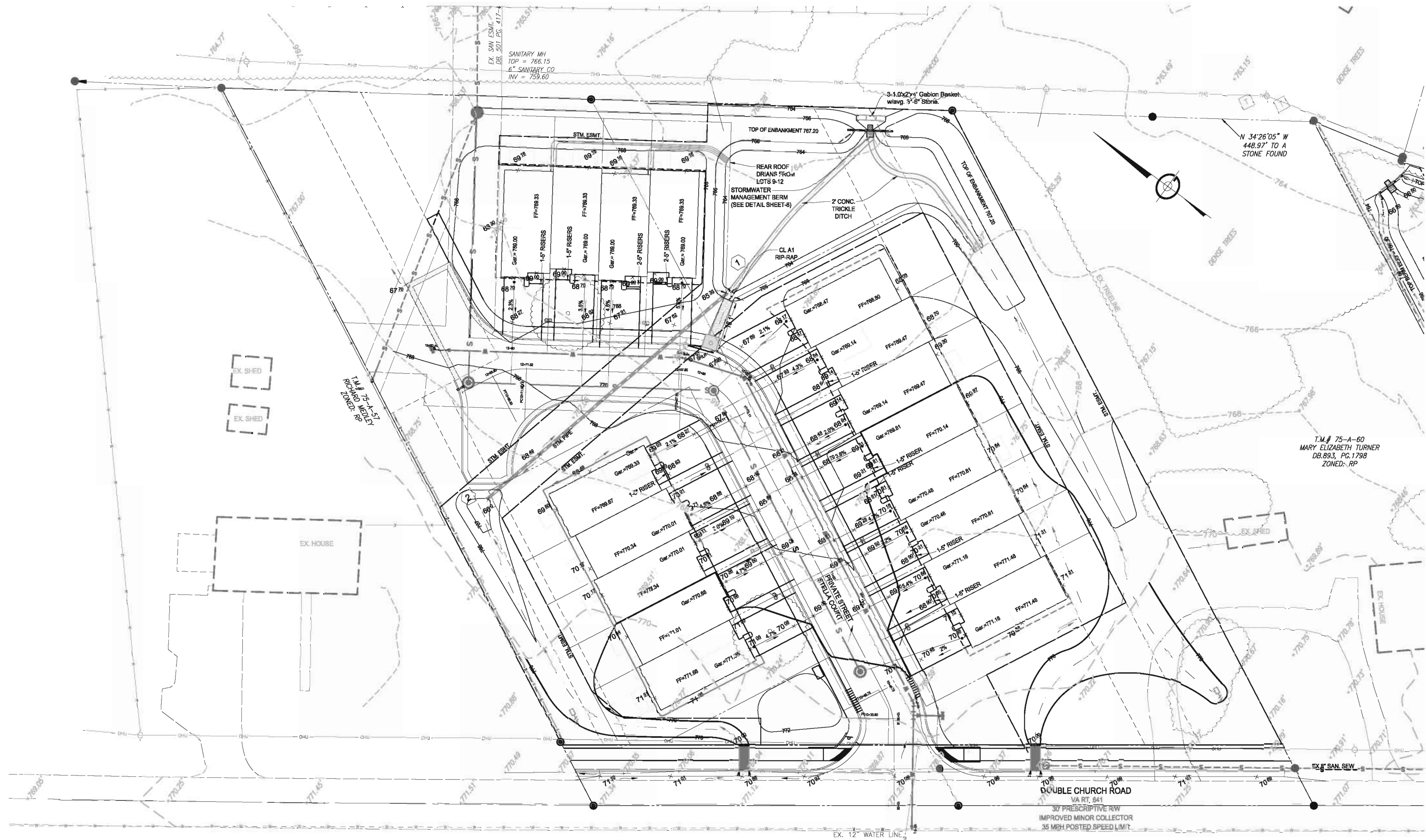

151 Windy Hill Lane
 Winchester, Virginia 22602
 Telephone: (540) 662-4185
 Fax: (540) 722-9528
 www.greenwayeng.com



PROUDLY SERVING VIRGINIA & WEST VIRGINIA
 OFFICES IN: WINCHESTER, VA & MARTINSBURG, WV

GRADING PLAN
LIBERTY CHASE - 17 LOT TOWNHOUSE

T.M. #75-A-58, 59

OPEQUON MAGISTERIAL DISTRICT
 FREDERICK COUNTY, VIRGINIA

| Rev. No. | Date |
|----------|------|
| | |



DATE: 2-15-2019

SCALE: 1" = 20'

DESIGNED BY: JNT

FILE NO. 4634T

SHEET 7 OF 14

15-19

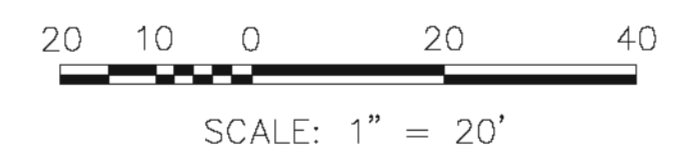

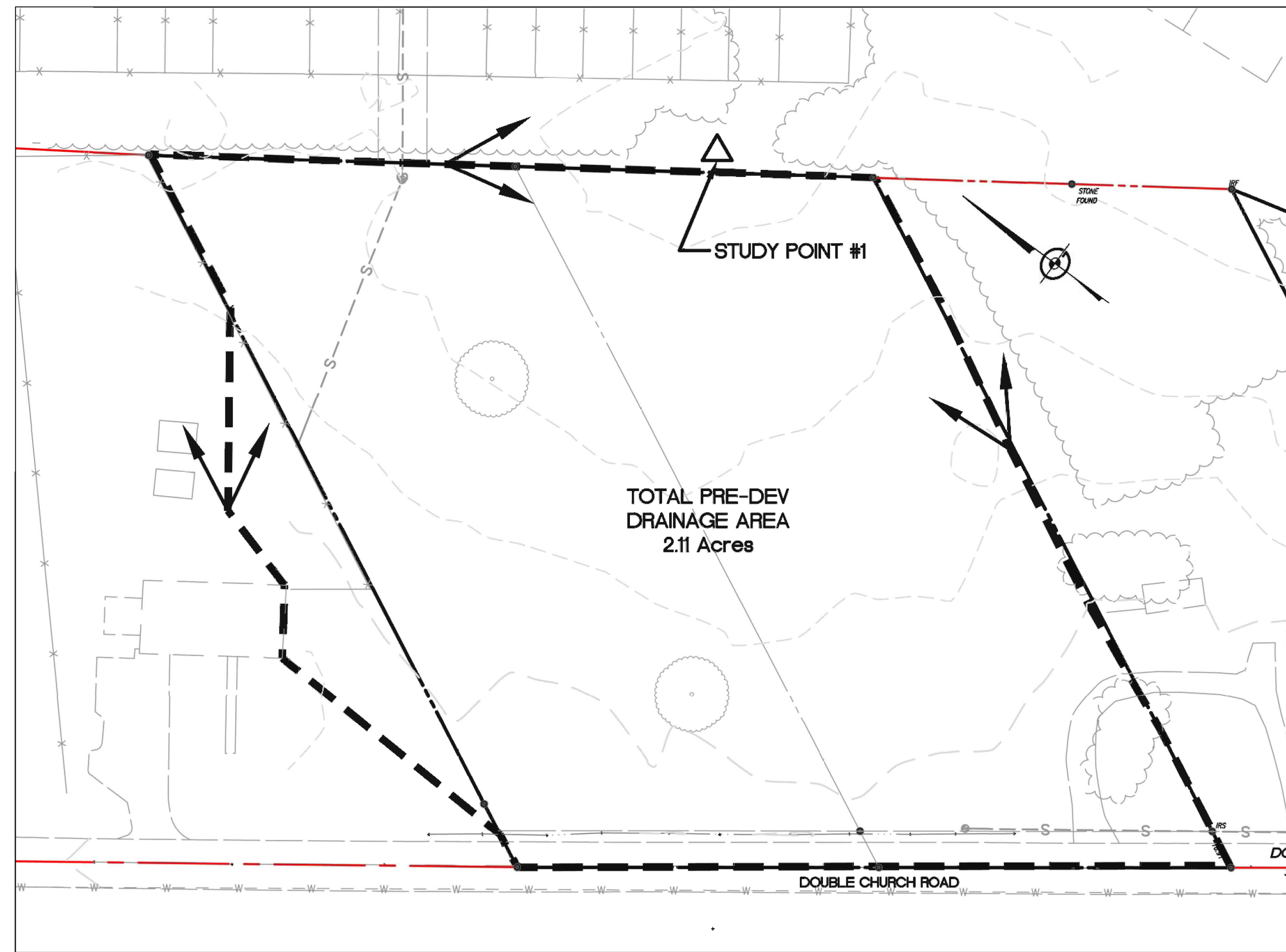

EXISTING DRAINAGE DIVIDES

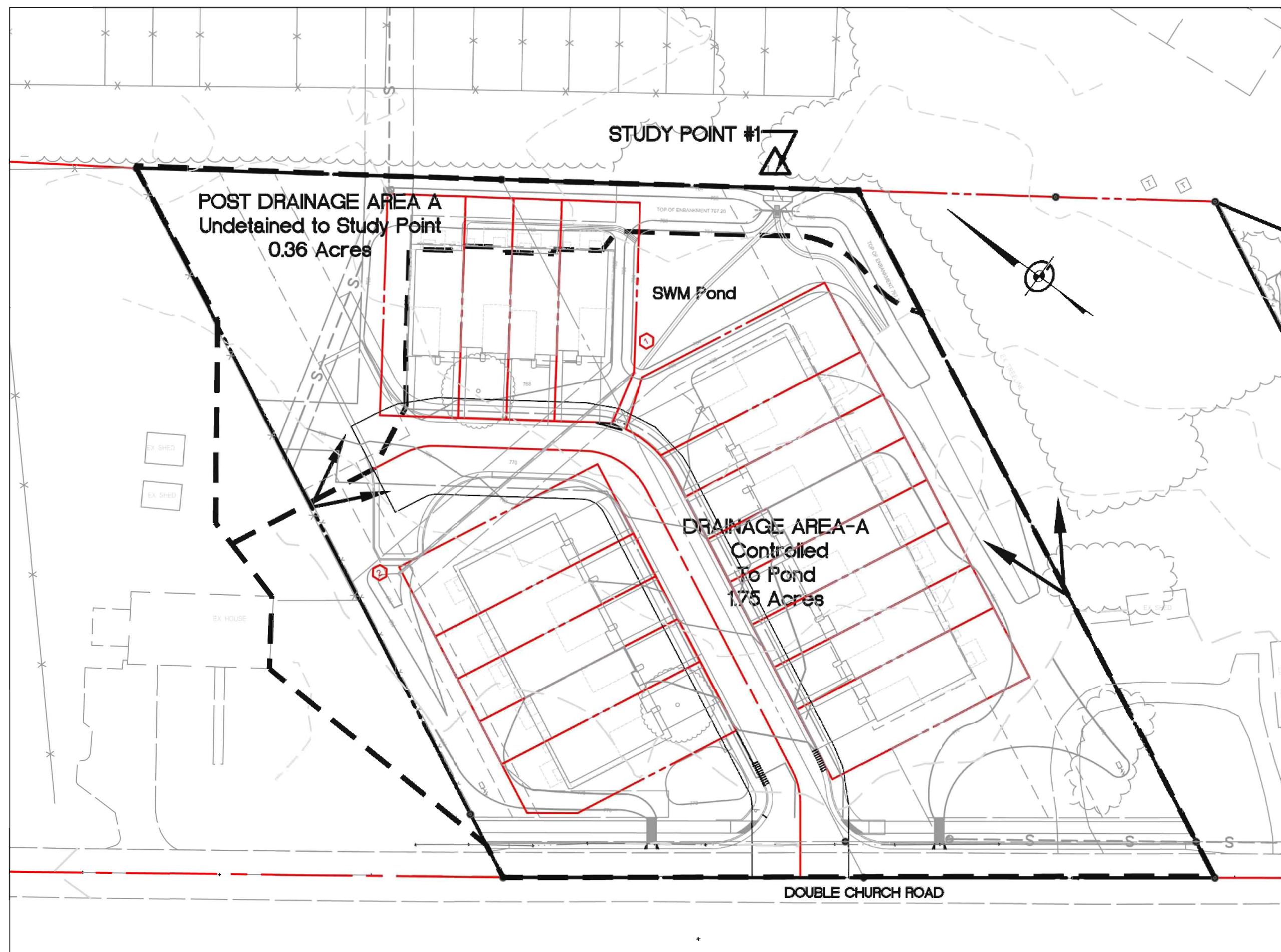

PROPOSED DRAINAGE DIVIDES

Overview

Liberty Chase is a new development of 2 parcel which will be consolidated for a combined 1.9718 acres 17 unit townhouse subdivision. The project is located on the east side of Double Church Road, Route 641 in Frederick County Virginia and is within the Opequon Magisterial District. The property is identified in the Frederick County tax maps as property identification number 75-A-58 & 75-A-59 and is currently zoned residential performance (RP). This project proposes 17 single family Attached (Townhouse) units associated level ways. The site area is 1.9718 acres of which approximately all will be disturbed for construction. To meet SWM requirements we are proposing a stormwater management pond. To meet BMP requirements we are proposing purchasing water quality credits.

- 1. Pre-development Conditions**
The site is mostly scrub brush and drains uncontrolled northward to the back east corner of the site towards Study Point #1. The existing soils for this site are 3b, blairton all loam (hydrologic soils group). Study point 1 has a drainage area of 2.11.
- 2. Post-development Conditions**
The post-development conditions encompass the entirety of the site and includes a small portion off-site draining to the proposed stormwater management facility. The majority of the construction is located within study point #1. The proposed stormwater management pond is located in the drainage area to study point #1. The on-site stormwater management facility will control approximately 1.75 acres of drainage with 0.36 acres undisturbed.
- 3. Water Quality Control (BMP)**
The Virginia Runoff Reduction Method for New Development Worksheet v3.0-2011 Standards and Specifications was used to verify compliance of the water quality control requirements. The required phosphorus reduction for the site is 1.33 lbs/yr. Water quality credits will be purchased for the 1.33 lbs/yr. required by the VRRM spreadsheet to comply with water quality (BMP) requirements.
- 4. Water Quantity Control (SWM)**
The proposed stormwater management pond is proposed to satisfy water quantity requirements of channel and flood protection.

- 5.1 Channel Protection**
To meet channel protection requirements a stormwater management pond is proposed and the Energy Balance Equation, from 9VAC25-870-66.5, was used to evaluate the study point. The proposed 10YR 24HR storm event was reduced to the required maximum peak flow rate determined by the Energy Balance Equation for Study Point 1.
- 10YR Storm Event**
DA Study Point #1 Required Peak Flow 1.26 cfs Post-development Peak Flow 0.98 cfs
- 5.2 Flood Protection**
To meet flood protection requirements of 9VAC25-870-66-C-2 to the post-development peak flow rate for the 10YR 24HR storm event was reduced to below predevelopment peak flow rates and no additional downstream analysis is necessary for Study Points 1. See summary table below. Additionally the 100YR 24HR storm was analyzed to address the downstream localized flooding, which resulted in a reduction to peak flow.
- 10YR Storm Event**
DA Study Point #1 Pre-development Peak Flow 6.26 cfs Post-development Peak Flow 3.79 cfs
- 100YR Storm Event**
DA Study Point #1 Pre-development Peak Flow 11.60 cfs Post-development Peak Flow 11.60 cfs

The design engineer shall be required to certify that the stormwater management facilities have been constructed in accordance with the approved plan.

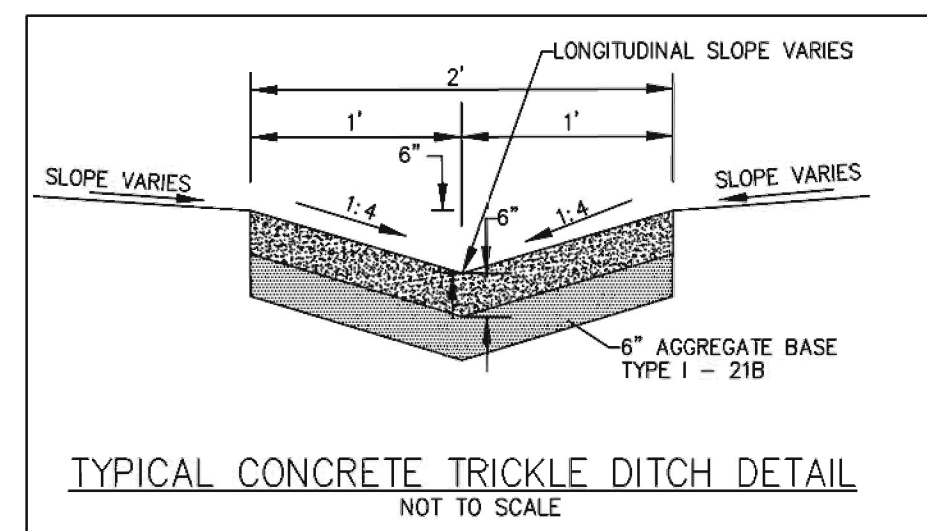

TYPICAL CONCRETE TRICKLE DITCH DETAIL NOT TO SCALE

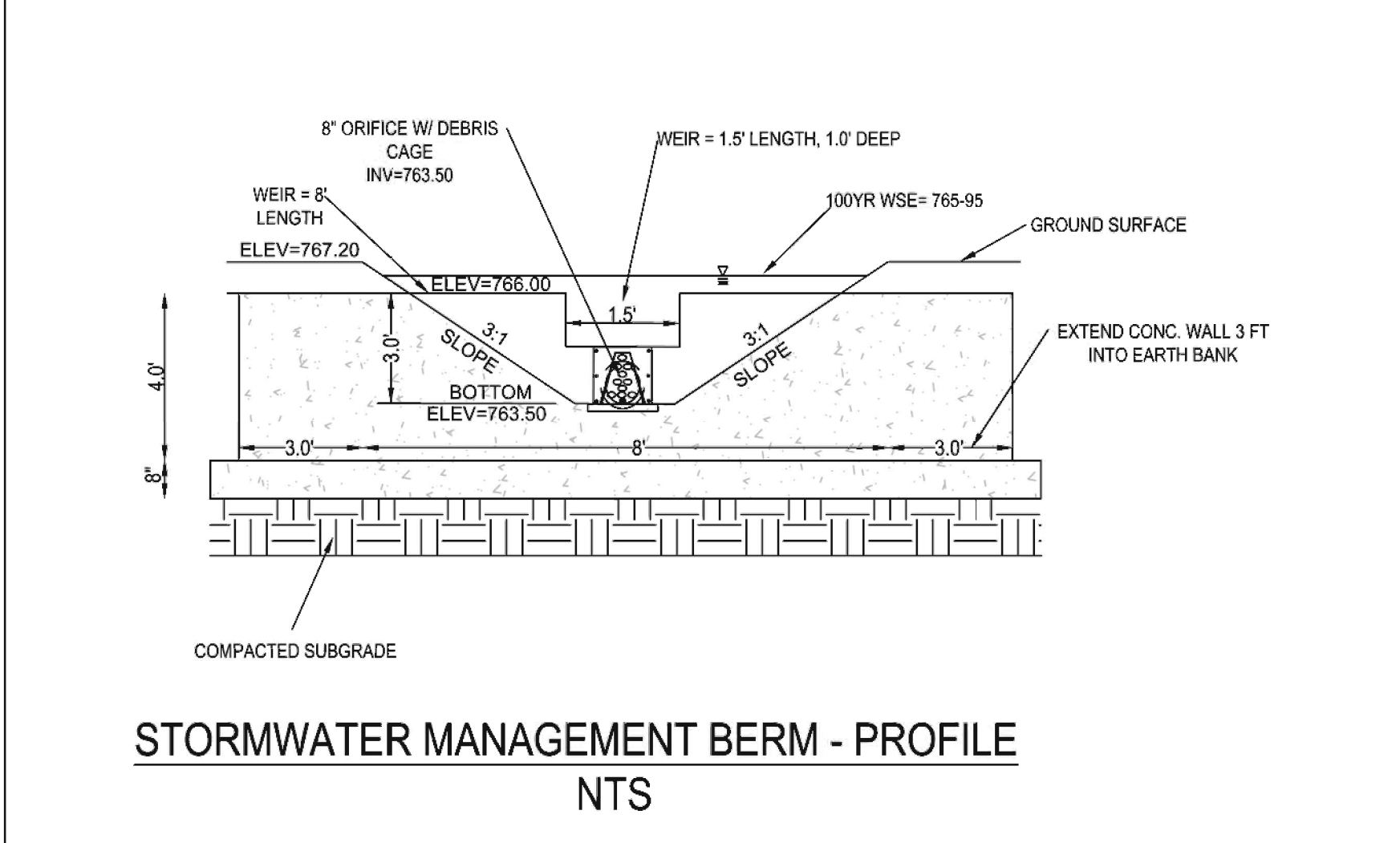

STORMWATER MANAGEMENT BERM - PROFILE NTS

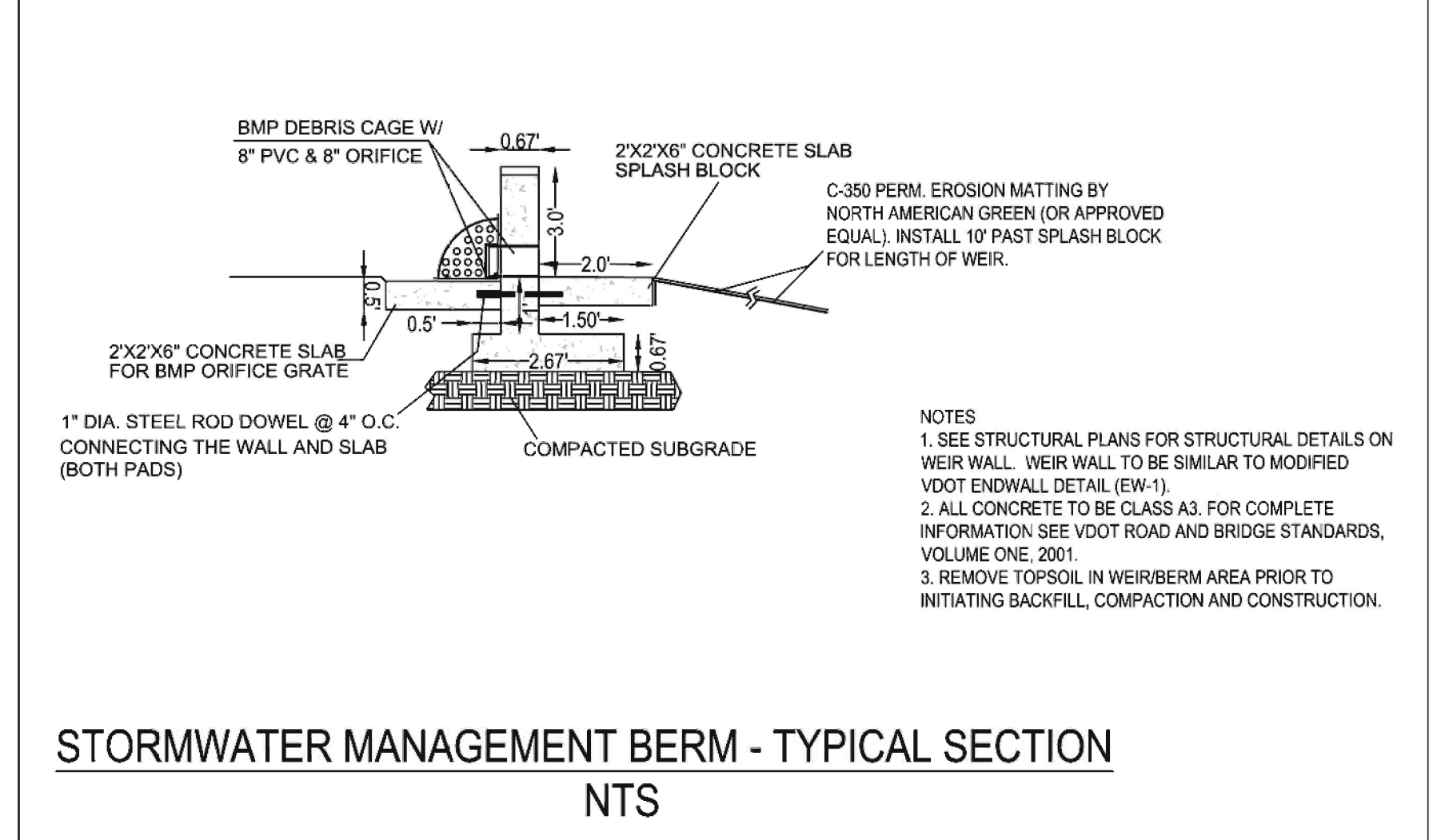

STORMWATER MANAGEMENT BERM - TYPICAL SECTION NTS

Study Point 1 Channel Protection Energy Balance Equation 1YR 24HR Storm Event

Liberty Chase
2/15/2018

I.F. (Improvement Factor) equals 0.8 for sites > 1 acre or 0.9 for sites < 1 acre
 $Q_{developed}$ The allowable peak flow rate of runoff from the developed site.
 $RV_{developed}$ The volume of runoff from the site in the developed condition.
 $Q_{pre-developed}$ The peak flow rate of runoff from the site in the pre-developed condition.
 $RV_{pre-developed}$ The volume of runoff from the site in the pre-developed condition.
 Q_{forest} The peak flow rate of runoff from the site in a forested condition.
 RV_{forest} The volume of runoff from the site in a forested condition.

| | | |
|----------------------|----------|--|
| Site Area | 1.97 AC | (*note: offsite area included in runoff volumes to determine allowable release at study point) |
| I.F. | 0.8 | |
| $RV_{developed}$ | 8,146 cf | convert to acre-feet <input type="text" value="0.187"/> af* |
| $Q_{pre-developed}$ | 1.94 cfs | |
| $RV_{pre-developed}$ | 6,621 cf | convert to acre-feet <input type="text" value="0.152"/> af* |
| Q_{forest} | 1.19 cfs | |
| RV_{forest} | 3,093 cf | convert to acre-feet <input type="text" value="0.071"/> af* |

Allowable peak flow rate with I.F.
 $Q_{developed} \leq (I.F. * Q_{pre-developed} * RV_{pre-developed}) / RV_{developed}$
 $Q_{developed} = 1.26$ cfs

Allowable peak flow rate with Forest
 $Q_{developed} \leq (Q_{forest} * RV_{forest}) / RV_{developed}$
 $Q_{developed} = 0.45$ cfs

Under no condition shall $Q_{developed}$ be greater than $Q_{pre-developed}$ nor shall $Q_{developed}$ be required to be less than that calculated with the Forest equation.

Use $Q_{developed} = 1.26$ cfs Ok
 as required release rate

Actual release rate 0.98 cfs Channel Protection Requirement Met

Old Dominion NATURAL RESOURCES, LLC

Date: February 15, 2019
 To: Freeman, LLC
 From: Old Dominion Natural Resources, LLC
 100 Box 604
 Stephens City, Virginia 22655
 Subject: Potomac Watershed - Nutrient Credit Availability
 Project Reference: Liberty Chase - HUC 0004

This letter is to confirm the availability of 1.33 lbs/yr authorized nutrient credits ("Nutrient Credits") from Old Dominion Natural Resources, LLC's upstream (ponding or approved) Potomac nutrient bank facility for use by permit applicants within the Potomac watershed, to include the subject property HUC00070004, to compensate for nutrient loadings in excess of state or local regulations, as per Virginia Code § 62.1-44.15.35 and § 62.1-44.19.14 and Virginia Administrative Code 9VAC 25-820-10 et seq. These Nutrient Credits are generated and managed under the terms of the Banking Instruments known as the Cross-Jurisdiction Nutrient Reduction Implementation Plan ("NRIP").

Please feel free to contact me if you have any questions.
 Sincerely,
 Jeremy N. Twiddle
 OLD DOMINION NATURAL RESOURCES, LLC
 www.odnr.com | 540-974-0541 | odnr@comcast.net

DEQ Virginia Runoff Reduction Method New Development Compliance Spreadsheet - Version 3.0

BMP Design Specifications List: 2013 Draft Stds & Specs

Update Summary Sheet
 Print Preview Print

Site Summary
 Total Rainfall = 43 inches

Site Land Cover Summary

| | A Soils | B Soils | C Soils | D Soils | Totals | % of Total |
|--------------------------|---------|---------|---------|---------|--------|------------|
| Forest/Open (acres) | 0.60 | 0.00 | 0.00 | 0.00 | 0.00 | 0 |
| Managed Turf (acres) | 0.60 | 0.00 | 1.28 | 0.00 | 1.28 | 65 |
| Impervious Cover (acres) | 0.60 | 0.00 | 0.69 | 0.00 | 0.69 | 35 |
| | | | | | 1.97 | 100 |

Site Tn and Land Cover Nutrient Loads

| | |
|-------------------------------------|-------|
| Site Rv | 0.68 |
| Treatment Volume (ft ³) | 3,402 |
| TP Load (lb/yr) | 2.14 |
| TN Load (lb/yr) | 15.29 |

Total TP Load Reduction Required (lb/yr) 1.33

Site Compliance Summary

| | |
|--|------|
| Total Runoff Volume Reduction (ft ³) | 0 |
| Total TP Load Reduction Achieved (lb/yr) | 0.60 |
| Total TN Load Reduction Achieved (lb/yr) | 0.60 |
| Remaining Post Development TP Load (lb/yr) | 2.14 |
| Remaining TP Load Reduction (lb/yr) Required | 1.33 |

WATER QUALITY COMPLIANCE NOTE:

IN ACCORDANCE WITH THE VIRGINIA STORMWATER MANAGEMENT PROGRAM (VSMMP) REGULATIONS (9VAC25-870), CALCULATIONS AND ANALYSIS OF THE SITE UTILIZING THE VIRGINIA RUNOFF REDUCTION METHOD SPREADSHEET FOR NEW DEVELOPMENT HAS RESULTED IN THE REQUIRED REDUCTION TO ACHIEVE COMPLIANCE OF REMOVAL OF 1.33 lbs/yr. THE PROJECT DISTURBED AREA IS LESS THAN 5 ACRES AND LESS THAN 10 lbs/yr POST CONSTRUCTION LOAD TO THE WATERSHED, THEREFORE THIS PROJECT PROPOSED TO PROVIDE OFFSET OPTIONS FOR ITS CONSTRUCTION ACTIVITY. IN ACCORDANCE AND AS PER VIRGINIA CODE § 62.1-44.15.35 AND § 62.1-44.19.14 AND VIRGINIA ADMINISTRATIVE CODE 9 VAC 25-820-10 ET SEQ, SUBJECT PROJECT WILL PROVIDE CERTIFICATION TO BOTH DEQ AND FREDERICK COUNTY PRIOR TO ISSUANCE OF LAND DISTURBANCE A AFFIDAVIT OF CREDIT SALE FOR 1.33 POUNDS OF PHOSPHORUS FROM ONE OF DEQ APPROVED NUTRIENT BANK FACILITIES FOR FREDERICK COUNTY WITHIN THE POTOMAC WATERSHED.

151 Windy Hill Lane
 Winchester, Virginia 22602
 Telephone: (540) 662-4185
 Fax: (540) 722-9528
 www.greenwayeng.com

GREENWAY ENGINEERING

PROUDLY SERVING VIRGINIA & WEST VIRGINIA
 OFFICES IN: WINCHESTER, VA & MARTINSBURG, WV

STORMWATER MANAGEMENT & WATER QUALITY PLAN

LIBERTY CHASE - 17 LOT TOWNHOUSE

OPEQUON MAGISTERIAL DISTRICT
 FREDERICK COUNTY, VIRGINIA

| | |
|----------|------|
| Rev. No. | Date |
| | |

DATE: 2-15-2019

SCALE: 1" = 50'

DESIGNED BY: JNT

FILE NO. 4634T

SHEET 8 OF 14

15-19

COMMONWEALTH OF VIRGINIA
 TUNG NHI ADHIKUSUMA
 Lic. No. 28715
 2/26/19
 PROFESSIONAL ENGINEER

HY-8 Culvert Analysis Report

Crossing Discharge Data

Discharge Selection Method: Specify Minimum, Design, and Maximum Flow
 Minimum Flow: 0.7 cfs
 Design Flow: 0.98 cfs
 Maximum Flow: 1.39 cfs

Table 1 - Summary of Culvert Flows at Crossing: Crossing 1

| Headwater Elevation (ft) | Total Discharge (cfs) | Culvert 1 Discharge (cfs) | Roadway Discharge (cfs) | Iterations |
|--------------------------|-----------------------|---------------------------|-------------------------|-------------|
| 766.52 | 0.70 | 0.70 | 0.00 | 1 |
| 766.55 | 0.77 | 0.77 | 0.00 | 1 |
| 766.58 | 0.84 | 0.84 | 0.00 | 1 |
| 766.60 | 0.91 | 0.91 | 0.00 | 1 |
| 766.63 | 0.98 | 0.98 | 0.00 | 1 |
| 766.63 | 0.98 | 0.98 | 0.00 | 1 |
| 766.68 | 1.11 | 1.11 | 0.00 | 1 |
| 766.70 | 1.18 | 1.18 | 0.00 | 1 |
| 766.73 | 1.25 | 1.25 | 0.00 | 1 |
| 766.75 | 1.32 | 1.32 | 0.00 | 1 |
| 766.78 | 1.39 | 1.39 | 0.00 | 1 |
| 768.50 | 4.06 | 4.06 | 0.00 | Overtopping |

Rating Curve Plot for Crossing: Crossing 1

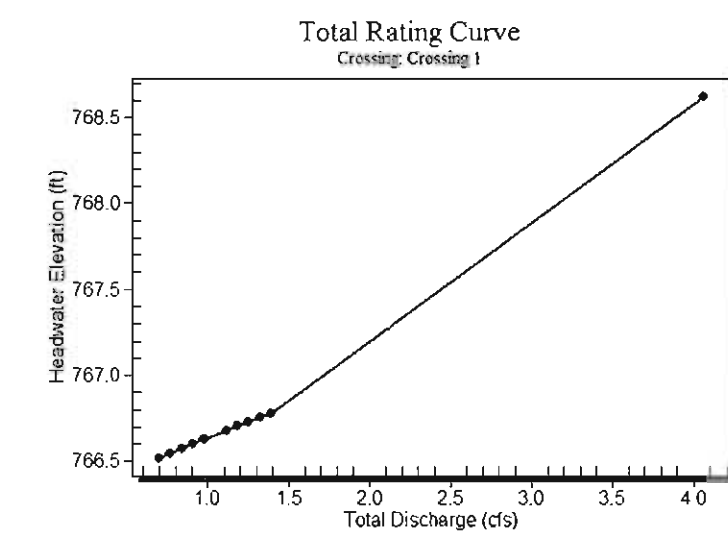

Table 2 - Culvert Summary Table: Culvert 1

| Total Discharge (cfs) | Culvert Discharge (cfs) | Headwater Elevation (ft) | Inlet Control Depth (ft) | Outlet Control Depth (ft) | Flow Type | Normal Depth (ft) | Critical Depth (ft) | Outlet Depth (ft) | Tailwater Depth (ft) | Outlet Velocity (ft/s) | Tailwater Velocity (ft/s) |
|-----------------------|-------------------------|--------------------------|--------------------------|---------------------------|-----------|-------------------|---------------------|-------------------|----------------------|------------------------|---------------------------|
| 0.70 | 0.70 | 766.52 | 0.520 | 0.0 | 1-S2n | 0.336 | 0.343 | 0.336 | 0.181 | 2.922 | 2.166 |
| 0.77 | 0.77 | 766.55 | 0.548 | 0.0 | 1-S2n | 0.353 | 0.362 | 0.353 | 0.171 | 3.007 | 2.244 |
| 0.84 | 0.84 | 766.58 | 0.575 | 0.0 | 1-S2n | 0.370 | 0.380 | 0.370 | 0.161 | 3.072 | 2.315 |
| 0.91 | 0.91 | 766.60 | 0.602 | 0.0 | 1-S2n | 0.386 | 0.397 | 0.386 | 0.150 | 3.133 | 2.382 |
| 0.98 | 0.98 | 766.63 | 0.628 | 0.0 | 1-S2n | 0.402 | 0.413 | 0.402 | 0.140 | 3.200 | 2.445 |
| 0.98 | 0.98 | 766.63 | 0.630 | 0.0 | 1-S2n | 0.403 | 0.414 | 0.403 | 0.140 | 3.200 | 2.449 |
| 1.11 | 1.11 | 766.68 | 0.680 | 0.0 | 1-S2n | 0.433 | 0.444 | 0.433 | 0.127 | 3.312 | 2.562 |
| 1.18 | 1.18 | 766.70 | 0.705 | 0.0 | 1-S2n | 0.448 | 0.459 | 0.448 | 0.126 | 3.360 | 2.617 |
| 1.25 | 1.25 | 766.73 | 0.730 | 0.033 | 1-S2n | 0.463 | 0.472 | 0.463 | 0.124 | 3.407 | 2.671 |
| 1.32 | 1.32 | 766.75 | 0.755 | 0.071 | 1-S2n | 0.477 | 0.486 | 0.477 | 0.123 | 3.455 | 2.721 |
| 1.39 | 1.39 | 766.78 | 0.779 | 0.109 | 1-S2n | 0.492 | 0.499 | 0.492 | 0.121 | 3.497 | 2.770 |

* Full Flow Headwater elevation is below inlet invert.

Straight Culvert
 Inlet Elevation (invert): 766.00 ft, Outlet Elevation (invert): 765.35 ft
 Culvert Length: 130.00 ft, Culvert Slope: 0.0050

Culvert Performance Curve Plot: Culvert 1

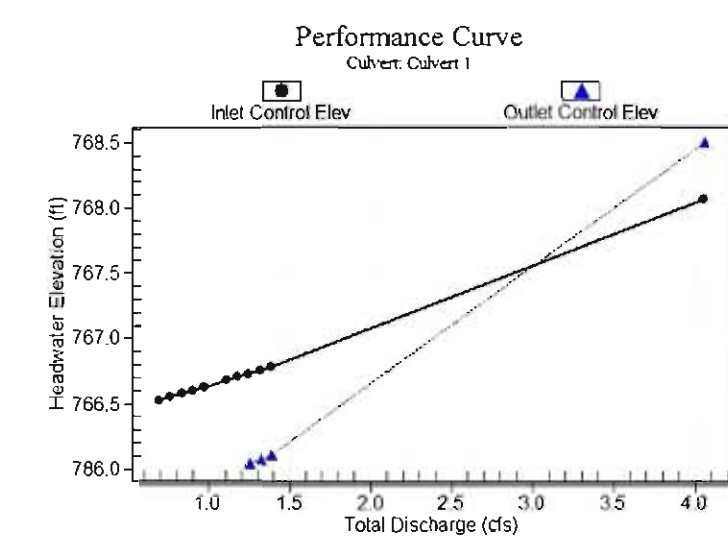

Water Surface Profile Plot for Culvert: Culvert 1

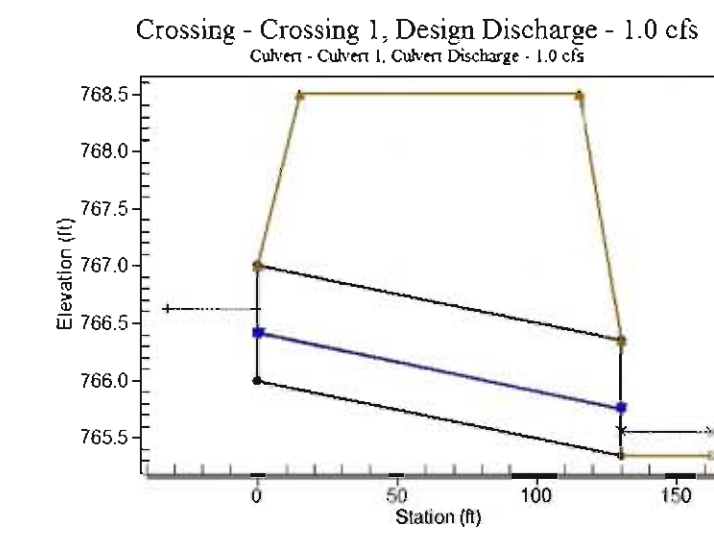

Site Data - Culvert 1

Site Data Option: Culvert Invert Data
 Inlet Station: 0.00 ft
 Inlet Elevation: 766.00 ft
 Outlet Station: 130.00 ft
 Outlet Elevation: 765.35 ft
 Number of Barrels: 1

Culvert Data Summary - Culvert 1

Barrel Shape: Circular
 Barrel Diameter: 1.00 ft
 Barrel Material: Smooth HDPE
 Embedment: 0.00 in
 Barrel Manning's n: 0.0120
 Culvert Type: Straight
 Inlet Configuration: Thin Edge Projecting
 Inlet Depression: None

Table 3 - Downstream Channel Rating Curve (Crossing: Crossing 1)

| Flow (cfs) | Water Surface Elev. (ft) | Depth (ft) | Velocity (ft/s) | Shear (psf) | Froude Number |
|------------|--------------------------|------------|-----------------|-------------|---------------|
| 0.70 | 765.51 | 0.16 | 2.17 | 0.05 | 0.95 |
| 0.77 | 765.52 | 0.17 | 2.24 | 0.05 | 0.96 |
| 0.84 | 765.53 | 0.18 | 2.31 | 0.06 | 0.96 |
| 0.91 | 765.54 | 0.19 | 2.38 | 0.06 | 0.96 |
| 0.98 | 765.55 | 0.20 | 2.44 | 0.06 | 0.96 |
| 0.98 | 765.55 | 0.20 | 2.45 | 0.06 | 0.96 |
| 1.11 | 765.57 | 0.22 | 2.56 | 0.07 | 0.97 |
| 1.18 | 765.58 | 0.23 | 2.62 | 0.07 | 0.97 |
| 1.25 | 765.58 | 0.23 | 2.67 | 0.07 | 0.97 |
| 1.32 | 765.59 | 0.24 | 2.72 | 0.08 | 0.97 |
| 1.39 | 765.60 | 0.25 | 2.77 | 0.08 | 0.97 |

Tailwater Channel Data - Crossing 1

Tailwater Channel Option: Rectangular Channel
 Bottom Width: 2.00 ft
 Channel Slope: 0.0050
 Channel Manning's n: 0.0130
 Channel Invert Elevation: 765.35 ft

Roadway Data for Crossing: Crossing 1

Roadway Profile Shape: Constant Roadway Elevation
 Crest Length: 20.00 ft
 Crest Elevation: 768.50 ft
 Roadway Surface: Paved
 Roadway Top Width: 100.00 ft

Hydraulic Analysis Report

Project Data

Project Title: 4634T
 Designer:
 Project Date: Friday, June 01, 2018
 Project Units: U.S. Customary Units
 Notes:

Channel Analysis: Channel #2 (Combined Flow) 10YR

Notes: Concrete Ditch in Pond

Input Parameters

Channel Type: Trapezoidal
 Side Slope 1 (Z1): 3.0000 ft/ft
 Side Slope 2 (Z2): 3.0000 ft/ft
 Channel Width: 2.0000 ft
 Longitudinal Slope: 0.0060 ft/ft
 Manning's n: 0.0130
 Flow: 4.5500 cfs

Result Parameters

Depth: 0.3856 ft
 Area of Flow: 1.2174 ft²
 Wetted Perimeter: 4.4390 ft
 Hydraulic Radius: 0.2743 ft
 Average Velocity: 3.7374 ft/s
 Top Width: 4.3138 ft
 Froude Number: 1.2398
 Critical Depth: 0.4349 ft
 Critical Velocity: 3.1661 ft/s
 Critical Slope: 0.0038 ft/ft
 Critical Top Width: 4.61 ft
 Calculated Max Shear Stress: 0.1444 lb/ft²
 Calculated Avg Shear Stress: 0.1027 lb/ft²

CONCRETE DITCH COMPUTATIONS (POND)

Hydraulic Analysis Report

Project Data

Project Title: 4634T Inlet Comps
 Designer:
 Project Date: Friday, June 01, 2018
 Project Units: U.S. Customary Units
 Notes:

Curb and Gutter Analysis: Inlet Comp

Notes:

Gutter Input Parameters

Longitudinal Slope of Road: 0.0150 ft/ft
 Cross-Slope of Pavement: 0.0200 ft/ft
 Uniform Gutter Geometry
 Manning's n: 0.0130
 Gutter Width: 2.0000 ft
 Design Flow: 2.5800 cfs

Gutter Result Parameters

Width of Spread: 8.8177 ft
 Gutter Depression: 0.0000 in
 Area of Flow: 0.7775 ft²
 Eo (Gutter Flow to Total Flow): 0.4968
 Gutter Depth at Curb: 2.1162 in

Inlet Input Parameters

Inlet Location: Inlet in Sag
 Percent Clogging: 0.0000 %
 Inlet Type: Curb Opening
 Length of Inlet: 6.0000 ft
 Curb opening height: 5.5000 in
 Local Depression: 2.0000 in

Inlet Result Parameters

Perimeter: 9.6000 ft
 Effective Perimeter: 9.6000 ft
 Area: 3.7500 ft²
 Effective Area: 3.7500 ft²
 Depth at curb face (upstream of local depression): 0.2390 ft
 Computed Width of Spread at Sag: 11.9504 ft
 Flow type: Weir Flow
 Efficiency: 1.0000

INLET COMPUTATIONS MODIFIED DI-3B

LOCATION: Channel #1

Appendix 7B-4 RIPRAP DESIGN WORK SHEET FOR STANDARD VDOT RIPRAP SIZES ONLY

CHANNEL DATA

Q= 2.58 cfs
 S= 0.029 ft/ft
 d= 0.223 ft
 A= 0.99 sqft

P= 4.996 ft
 R=A/P= 0.2 ft
 V= 2.61 fps
 Side Slope= 2 :1

DETERMINE RIPRAP SIZE

Convert Side Slope to Side Slope Angle
 $K_1 = [1 - (\sin^2 \theta / \sin^2 \phi)]^{0.5}$

$\phi = 42^\circ$
 $\theta = 26.57^\circ$
 $K_1 = 0.74$

For Specific Gravity = 2.65 and Stability Factor = 1.2
 $D_{50} = (0.001 \times V^3) / (d^{0.5} \times K_1^{1.5})$ $D_{50} \text{ Computed} = 0.06 \text{ ft}$

Note: All VDOT standard riprap (Class AI through Type II) is assumed to have a ϕ of approximately 42° and a Specific Gravity of 2.65. Therefore, the Computed D_{50} should be adjusted by the Stability Correction Factor (C_{sf}) (if any) to derive a Final D_{50} . The VDOT standard class of riprap with the next higher D_{50} should be specified.

Correction Factor For Stability Factor (SF) other than 1.2 (Default=1.0)

From Appendix 7D-5 select SF
 $C_{sf} = (SF/1.2)^{1.5}$

Final $D_{50} = C_{sf} \times \text{Computed } D_{50} = 0.06 \text{ ft}$
 RIPRAP RECOMMENDATION: VDOT (Class) (Type) Class A1
 Thickness (T) = (2 x D_{50} MSD) T = 22 inches

Source: VDOT

RIP-RAP COMPUTATIONS @ MODIFIED DI-3B

151 Windy Hill Lane
 Winchester, Virginia 22602
 Telephone: (540) 662-4165
 Fax: (540) 722-9528
 www.greenwayeng.com



PROUDLY SERVING VIRGINIA & WEST VIRGINIA
 OFFICES IN WINCHESTER, VA & MARTINSBURG, WV

LIBERTY CHASE - 17 LOT TOWNHOUSE

STORM SEWER COMPS

T.M. #75-A-58, 59

OPEQUON MAGISTERIAL DISTRICT
 FREDERICK COUNTY, VIRGINIA

Rev. No. | Date

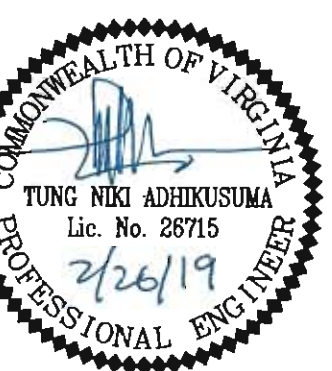

DATE: 2-15-2019

SCALE: AS SHOWN

DESIGNED BY: JNT

FILE NO. 4634T

SHEET 9 OF 14

15-19

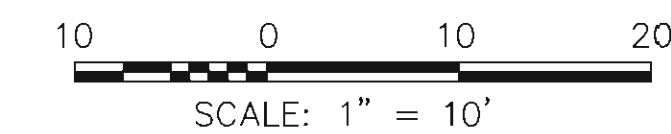

GENERAL CONDITIONS

SCOPE OF WORK

THE LANDSCAPE CONTRACTOR SHALL PROVIDE ALL MATERIALS, LABOR AND EQUIPMENT TO COMPLETE ALL LANDSCAPE WORK AS SHOWN ON THE PLANS AND SPECIFICATIONS.

NOTE: IF CONTRACTOR BIDS ACCORDING TO THE PLANT LIST, HE/SHE SHOULD THOROUGHLY CHECK THE PLANT LIST QUANTITIES WITH THE SYMBOLS DRAWN ON THE PLAN, TO BE SURE THERE ARE NO DISCREPANCIES. IF THERE IS A DISCREPANCY BETWEEN THE DRAWING AND THE LIST ON THE PLANS, THE DRAWING TAKES PRECEDENCE.

STANDARDS

ALL PLANT MATERIAL WILL CONFORM TO THE CURRENT ISSUE OF THE AMERICAN STANDARD FOR NURSERY STOCK PUBLISHED BY THE AMERICAN NURSERY & LANDSCAPE ASSOCIATION (ANLA). PLANT MATERIAL MUST BE SELECTED FROM NURSERIES THAT HAVE BEEN INSPECTED AND CERTIFIED BY STATE PLANT INSPECTORS. COLLECTED MATERIAL MAY BE USED ONLY WHEN APPROVED BY OWNER'S REPRESENTATIVE. NOMENCLATURE WILL BE IN ACCORDANCE WITH HORTUS II BY L.H. BAILEY.

SUBSTITUTIONS: PRE-BID

IT IS THE LANDSCAPE CONTRACTOR'S RESPONSIBILITY TO MAKE EVERY REASONABLE EFFORT TO FIND THE PLANTS SPECIFIED BY THE LANDSCAPE ARCHITECT. THE LANDSCAPE CONTRACTOR MAY OFFER SUBSTITUTIONS TO THE LANDSCAPE ARCHITECT FOR HIGHER CONSIDERATION. THE LANDSCAPE CONTRACTOR WILL NOTIFY THE LANDSCAPE ARCHITECT IF THERE ARE KNOWN DISEASES OR INSECT RESISTANT SPECIES THAT CAN BE SUBSTITUTED FOR A SELECTED PEST-PRONE PLANT. THE CONTRACTOR SHALL SUBMIT A BASE BID AS PER PLAN PLUS PRICE CLARIFICATIONS FOR ALL RECOMMENDED SUBSTITUTIONS.

SUBSTITUTIONS: POST-BID

IT IS THE INTENT TO ELIMINATE POST-BID SUBSTITUTIONS. HOWEVER, IN THE EVENT THAT THE CONTRACT MATERIAL HAS BECOME UNAVAILABLE, AN APPROPRIATE SUBSTITUTION MUST BE APPROVED BY THE OWNER'S REPRESENTATIVE.

UTILITIES AND UNDERGROUND FEATURES

THE LANDSCAPE CONTRACTOR SHALL NOTIFY UTILITY COMPANIES AND/OR THE GENERAL CONTRACTOR IN ADVANCE OF CONSTRUCTION TO LOCATE UTILITIES. IF THERE IS A CONFLICT WITH UTILITIES AND THE PLANTING, THE LANDSCAPE ARCHITECT SHALL BE RESPONSIBLE FOR RELOCATING PLANTS PRIOR TO THE PLANTING PROCESS. ANY COST DUE TO RELOCATING AFTER PLANTING SHALL BE BORNE BY THE OWNER. IF PLANTS ARE TO BE INSTALLED IN AREAS THAT SHOW OBVIOUS POOR DRAINAGE, AND THE PLANTS ARE INAPPROPRIATE FOR THAT CONDITION, THE LANDSCAPE CONTRACTOR SHALL NOTIFY THE LANDSCAPE ARCHITECT AND OWNER. IF THEY DEEM NECESSARY, THE PLANTS SHALL BE RELOCATED, THE CONTRACT SHALL BE ADJUSTED TO ALLOW FOR DRAINAGE CORRECTION AT A NEGOTIATED COST, OR THE PLANT SELECTION MODIFIED BY THE LANDSCAPE ARCHITECT TO ACCOMMODATE THE POOR DRAINAGE.

WARRANTY

THE STANDARD WARRANTY IS FOR ONE (1) YEAR PERIOD, EXCLUDING BULBS, SOD AND ANNUALS, COMMENCING ON THE DATE OF INITIAL ACCEPTANCE. ALL PLANTS SHALL BE ALIVE AND IN SATISFACTORY GROWTH AT THE END OF THE GUARANTEE PERIOD. ANY MATERIAL THAT IS 25% DEAD OR MORE SHALL BE CONSIDERED DEAD AND MUST BE REPLACED AT NO CHARGE. A TREE SHALL BE CONSIDERED DEAD WHEN THE MAIN LEADER HAS DIED BACK, OR 25% OF THE CROWN IS DEAD. REPLACEMENTS SHALL BE MADE DURING THE NEXT PLANTING PERIOD. REPLACEMENTS SHALL BE OF THE SAME TYPE, SIZE AND QUALITY AS ORIGINAL SPECIES UNLESS OTHERWISE NEGOTIATED.

NOTES:

- ALL SEEDED AND SODDED AREAS OF PROJECT WILL BE OF A DROUGHT TOLERANT MIX PER PENNINGTON SEED COMPANY.
- ALL STREET, INTERIOR AND PERIMETER TREES WILL HAVE A MULCH BED CUT UNDER THE TREE EQUAL TO 6' RADIUS TREE TRUNK.

STANDARDS

A. PLANTS WILL BE IN ACCORDANCE WITH THE CURRENT ANLA'S STANDARDS AND CONFORM IN GENERAL TO REPRESENTATIVE SPECIES.

B. BALLED AND BURLAPPED (B&B)

- BALLED AND BURLAPPED PLANTS SHALL BE DUG WITH FIRM ROOT BALLS FREE OF NOXIOUS WEEDS. THERE SHOULD BE NO EXCESS SOIL ON TOP OF THE ROOTBALL OR AROUND THE TRUNK
- BALL SIZES SHALL BE IN ACCORDANCE WITH ANLA STANDARDS.
- CALIPER AND HEIGHT MEASUREMENT: IN SIZE GRADING B&B SINGLE TRUNK TREES, CALIPER SHALL TAKE PRECEDENCE OVER HEIGHT. CALIPER OF THE TRUNK SHALL BE TAKEN 6" ABOVE GROUND LEVEL (UP TO AND INCLUDING 4" CALIPER SIZE) AND 12" ABOVE THE GROUND LEVEL FOR LARGER TREES. FOR MULTIPLE-TRUNK TREES, HEIGHT MEASUREMENT SHALL TAKE PRECEDENCE OVER CALIPER.

C. CONTAINER - GROWN STOCK

- THE SIZE OF CONTAINER-GROWN SHRUBS IS MEASURED BY HEIGHT AND WIDTH OF THE PLANT. CONTAINER-GROWN TREES ARE MEASURED BY THE SAME STANDARDS LISTED IN B.3. ABOVE. THE ROOT SYSTEM OF CONTAINER-GROWN PLANTS SHALL BE WELL DEVELOPED AND WELL DISTRIBUTED THROUGH OUT THE CONTAINER.
- ALL CONTAINER-GROWN TREES AND SHRUBS THAT HAVE CIRCLING (GIRDLING) AND MATTED ROOTS SHALL BE TREATED IN THE FOLLOWING MANNER PRIOR TO PLANTING: SEPARATE THE ROOTS BY HAND, UNTANGLING SO CIRCLING ROOTS WILL NOT DAMAGE FUTURE OF THE PLANT. SEE PLANTING PROCEDURES FOR ALL CONTAINER-GROWN TREES & SHRUBS IN THIS SECTION.
- ALL CONTAINER-GROWN PLANTS SHOULD BE GROUPED AND WATERED DAILY UNTIL THEY ARE PLANTED IN THE LANDSCAPE. THE SOIL SHALL BE KEPT MOIST WITH THE EQUIVALENT OF ONE-INCH OF RAINFALL PER WEEK.

D. PRUNING SHALL BE DONE BEFORE PLANTING OR DURING THE PLANTING OPERATION. PRUNING DETAIL FOR TREES IN THIS SECTION.

E. ALL PLANT MATERIAL IN TRANSIT SHALL BE COVERED TO KEEP MATERIAL FROM DRYING OUT. THE COVERING SHALL COMPLY WITH THE STATE AND LOCAL LAWS PERTAINING TO THE TRANSPORT OF MATERIALS.

F. TREES SHALL BE PLACED IN AN UPRIGHT POSITION WITH THE ROOTBALL COVERED BY MULCH AND KEPT MOIST. TREES AND SHRUBS SHOULD NOT BE LEFT ON SITE UNPLANTED FOR MORE THAN 24-HOURS WITHOUT ADEQUATE WATER TO INSURE ROOT SURVIVAL.

INSPECTION

A. PLANTS MAY BE SUBJECT TO INSPECTION AND APPROVAL BY THE OWNER OR OWNER'S REPRESENTATIVE AT THE PLACE OF GROWTH OR HOLDING YARD FOR CONFORMITY TO SPECIFICATION REQUIREMENTS AS TO QUALITY, SIZE AND VARIETY.

B. PLANTS DAMAGED IN HANDLING OR TRANSPORTATION CAN BE REJECTED BY THE OWNER OR OWNER'S REPRESENTATIVE.

C. STATE NURSERY INSPECTION CERTIFICATES SHALL BE FURNISHED TO THE LANDSCAPE ARCHITECT UPON REQUEST.

PLANTING PROCEDURES FOR ALL CONTAINER-GROWN TREES & SHRUBS

A. REMOVE THE PLANT EITHER BY CUTTING OR INVERTING THE CONTAINER.

B. FOR UNTREATED PLASTIC CONTAINER-GROWN PLANTS WITH CIRCLING ROOTS, SEPARATE ROOTS BY HAND AND UNTANGLE ROOTS THE LENGTH OF THE ROOTBALL.

C. PLANT SHRUB OR TREE A MINIMUM OF 1/3 OF THE HEIGHT OF THE ROOTBALL ABOVE EXISTING GRADE.

D. APPLY A 2 TO 3" THICK LAYER OF APPROVED HARDWOOD MULCH. KEEP MULCH 6" AWAY FROM THE TRUNK OF ALL TREES AND SHRUBS.

E. PLANTS GROWN IN ROOT CONTAINMENT BAGS MUST HAVE BAGS REMOVED DURING THE PLANTING OPERATION. NO ADDITIONAL SLASHING OF THE ROOTBALL IS NECESSARY.

NOTES:

- PLANT SYMBOLS SHOWN ON PLANS ARE ILLUSTRATIVE IN SIZE. ACTUAL SIZES OF PLANTS ARE FOUND WITHIN PLANT LIST.
- ALL PLANTING SHALL CONFORM WITH SEC. 165-203.01B OF THE FREDERICK COUNTY ZONING ORDINANCE (PLANT SELECTION, PLANTING PROCEDURE, AND MAINTENANCE).
- ANY PLANT SUBSTITUTIONS MUST BE APPROVED IN WRITING BY THE FREDERICK COUNTY PLANNING DEPARTMENT.
- NO TREES OR SHRUBS SHOULD BE PLACED ON FCSA EASEMENTS (SHRUBS ONLY WOULD BE ALLOWED WHEN SHIELDING HEADLIGHT GLARE PER COUNTY ORDINANCE REQUIREMENTS SEC. 165-203.02)
- ALL LANDSCAPING SHALL IN GENERAL CONFORM WITH FREDERICK COUNTY ZONING ORDINANCE SEC. 165-203.01 LANDSCAPING REQUIREMENTS AND 165-203.02 BUFFER AND SCREENING REQUIREMENTS.
- ALL SITE LIGHTING SHALL CONFORM TO SECTION 165-201.07 OF THE FREDERICK COUNTY ZONING ORDINANCE AND WILL BE DOWNCAST AND FULL CUTOFF.

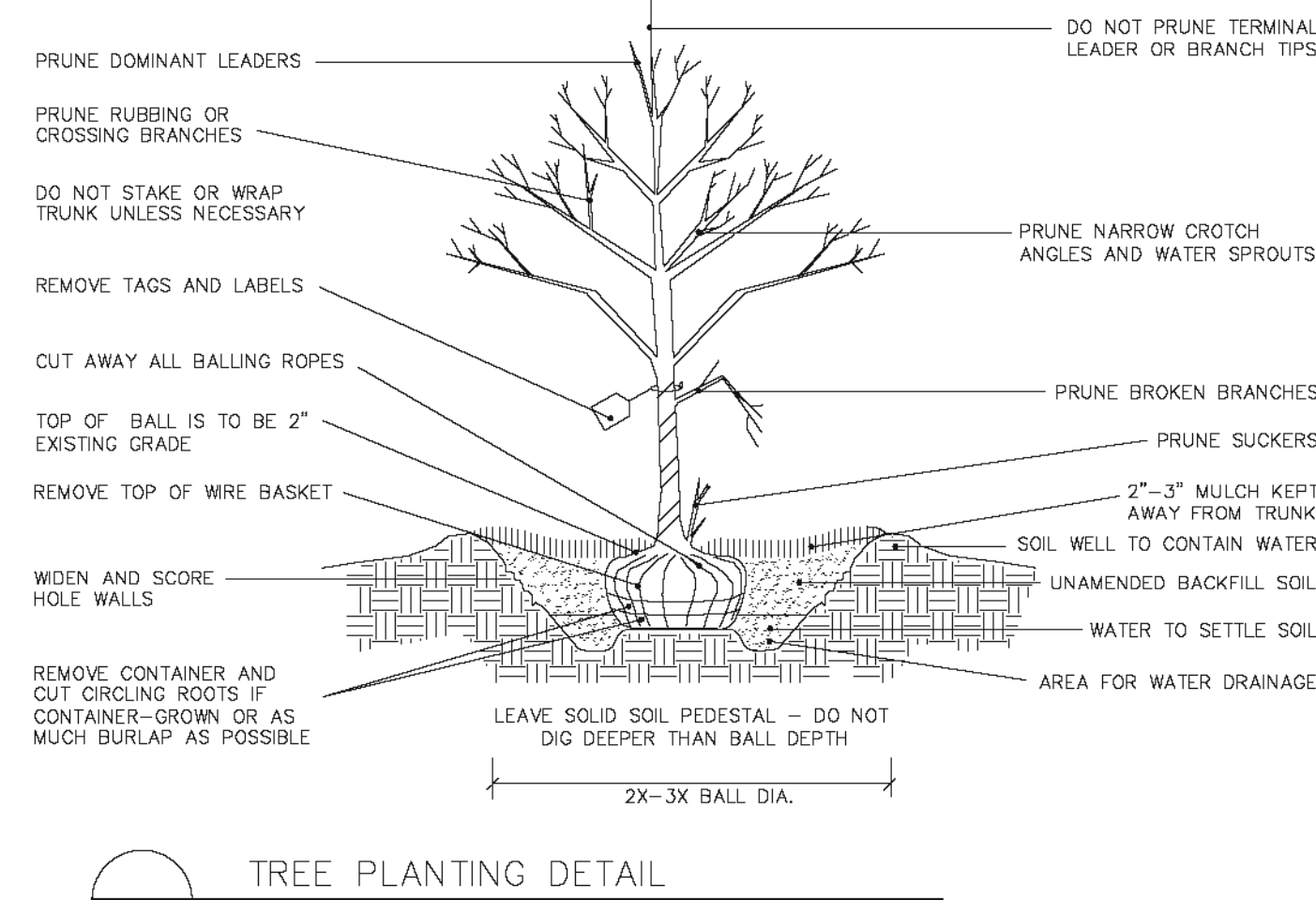
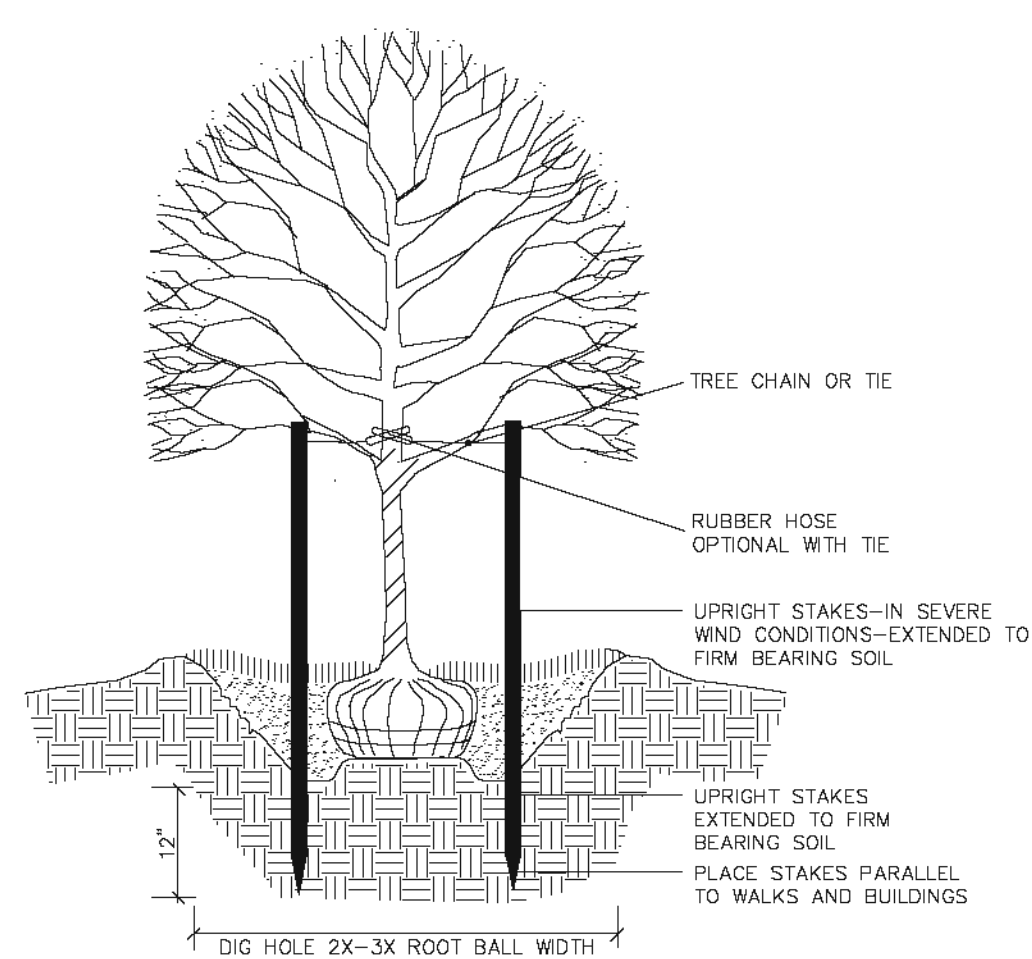
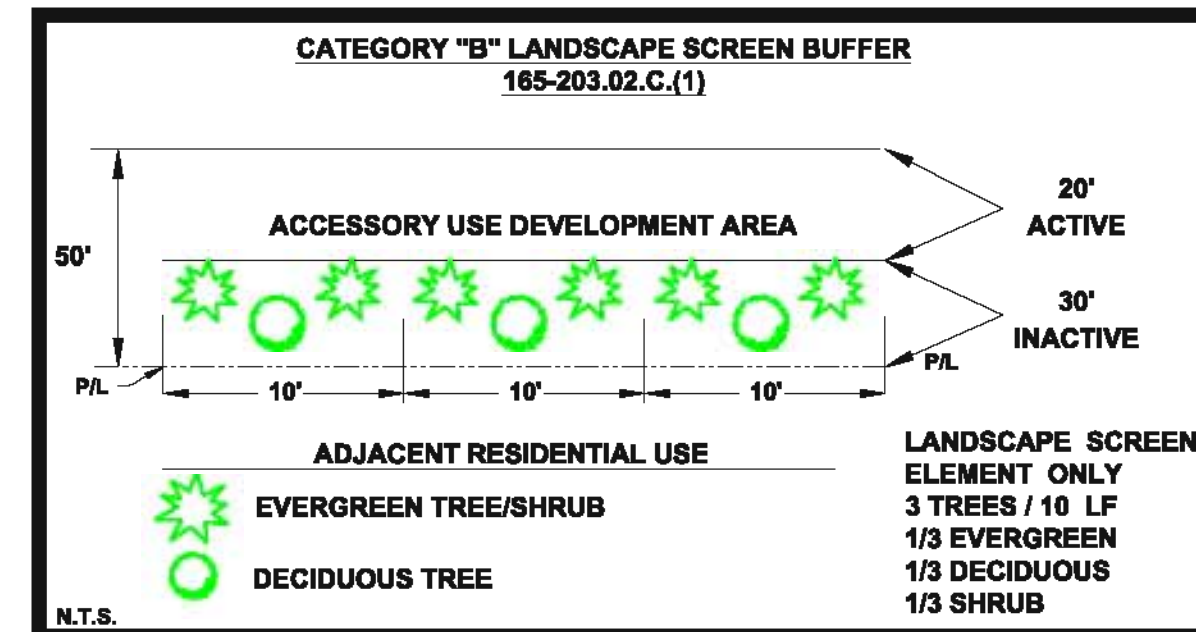
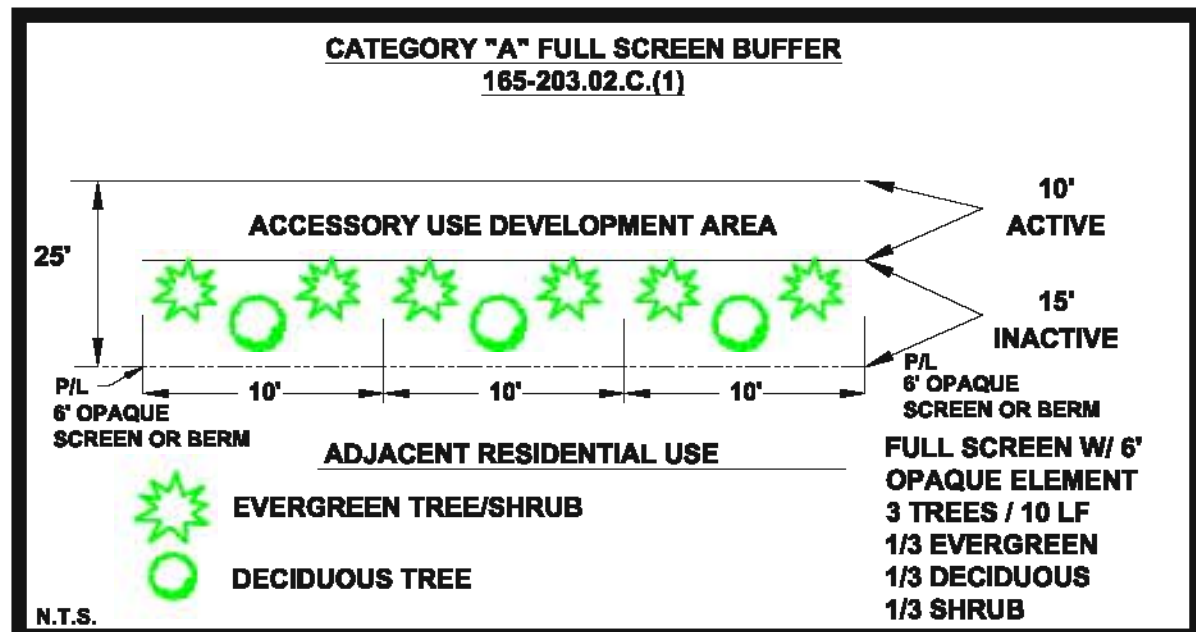
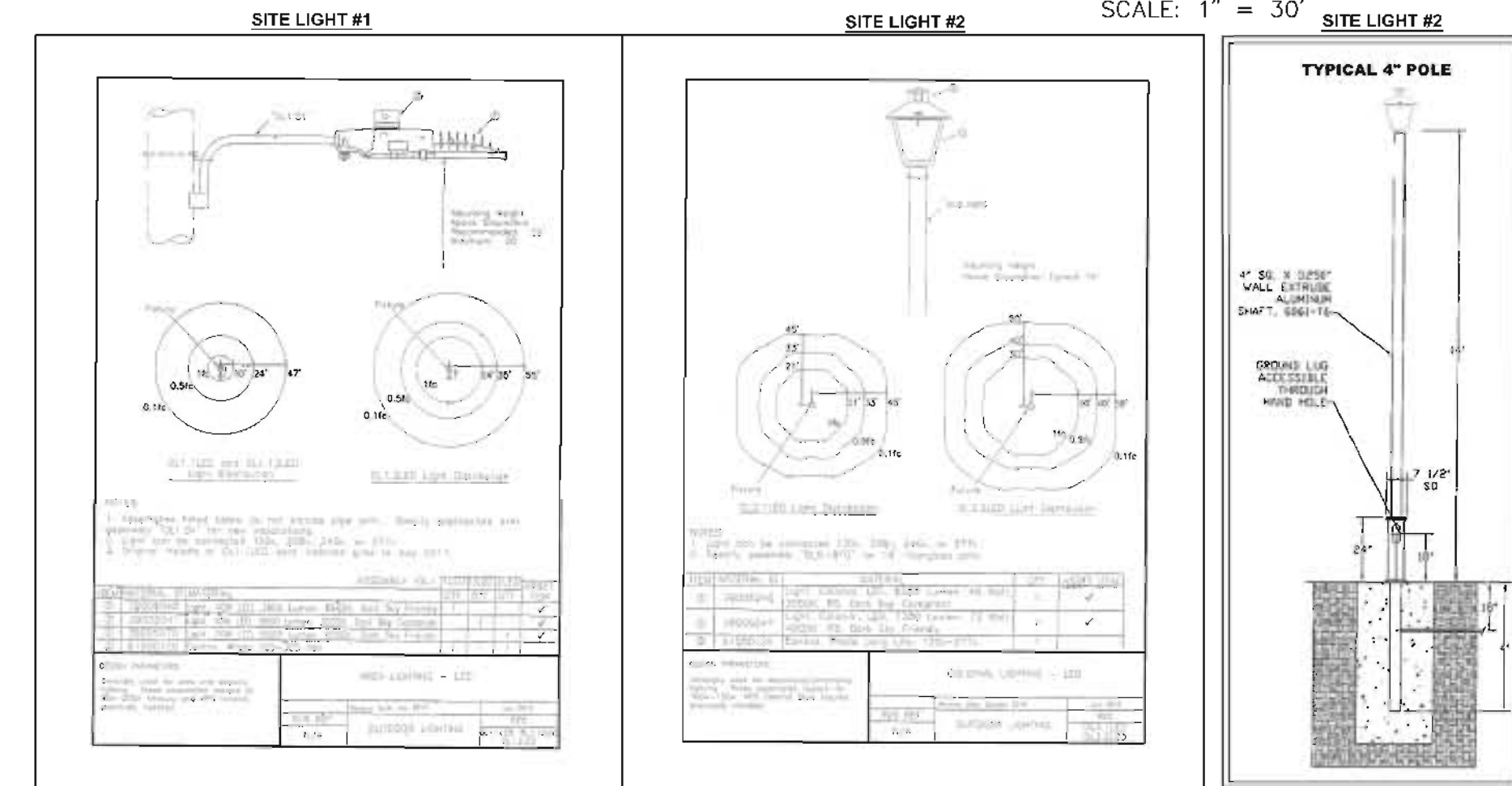
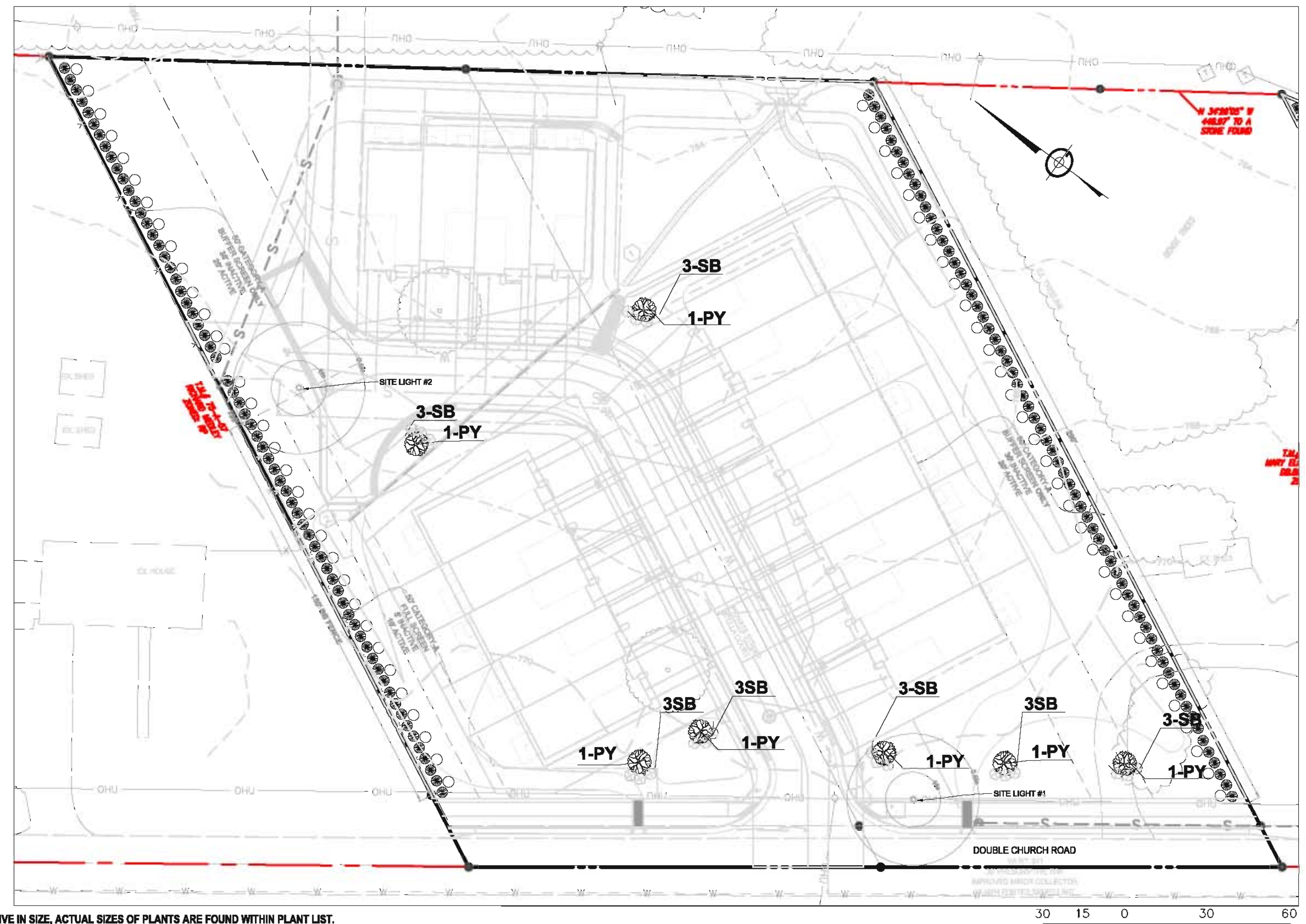

IN ACCORDANCE WITH FREDERICK COUNTY ZONING ORDINANCE 165-203.01 LANDSCAPING REQUIREMENTS, THIS DEVELOPMENT SHALL CONFORM TO ACHIEVE THE REQUIRED LANDSCAPING UTILIZING ORNAMENTAL LANDSCAPING IN ACCORDANCE WITH 165-201.01.A(2)(a) AS FOLLOWS:

ORNAMENTAL LANDSCAPING: 17 UNITS
 2 TREE PER 5 UNITS $\frac{1}{3} = 3.4x2 = 7$ TREES REQUIRED
 TOTAL TREES PROVIDED = 7
 6 SHRUBS PER 5 UNITS, $\frac{1}{3} = 3.4x6 = 21$ SHRUBS REQUIRED
 TOTAL SHRUBS PROVIDED = 21

RESIDENTIAL SEPARATION BUFFERS:
 EAST PROPERTY LINES (290')
 290/10 = 29 USE 29 29x3 TREES PER 10 LF = 87 TREES REQUIRED
 1/3 SHALL BE DECIDUOUS, 1/3 EVERGREEN, 1/3 SHRUB
 = 29 DECIDUOUS REQUIRED, 58 EVERGREEN REQUIRED
 = 29 DECIDUOUS PROVIDED, 58 EVERGREEN PROVIDED

WEST PROPERTY LINES (170')
 290/10 = 29 USE 29 29x3 TREES PER 10 LF = 87 TREES REQUIRED
 1/3 SHALL BE DECIDUOUS, 1/3 EVERGREEN, 1/3 SHRUB
 = 29 DECIDUOUS REQUIRED, 58 EVERGREEN REQUIRED
 = 29 DECIDUOUS PROVIDED, 58 EVERGREEN PROVIDED

OPEN SPACE CALCULATION:
 REQUIRED OPEN SPACE 30%
 1.9718 ACRES x .3 = 0.59 ACRES REQUIRED
 1.28 ACRES OR 0.64% PROVIDED > OPEN SPACE REQ. MET
 (REFER TO SHEET 8 FOR MANAGED TURF AREA DELINEATIONS)

MINIMUM REQUIREMENTS LANDSCAPE PLANT SCHEDULE

| KEY | BOTANICAL NAME | COMMON NAME | SIZE (HEIGHT) | QUANTITY | REMARKS |
|-----|------------------------------------|--------------------------|---------------|----------|---------|
| CO | Chamaecyparis obtusa | Hinoki False Cypress | 4-5'ht, 10# | 63 | BUFFER |
| CM | Cornus mas | Cornelian Cherry Dogwood | 4-5' ht. | 15 | BUFFER |
| JS | Juniperus scopulorum 'Blue Heaven' | Blue Heaven Juniper | 4-5'ht, 10# | 14 | BUFFER |
| PS | Picea sp. | Spruce | 2" cal. B&B | 16 | BUFFER |
| TO | Thuja occidentalis 'Emerald' | Emerald Green Arborvitae | 4-5'ht, 10# | 125 | BUFFER |
| PY | Prunus yedoensis | Yoshino Flowering Cherry | 2" cal. B&B | 7 | TREES |
| | | | TOTAL | 239 | |
| SB | Spiraea bumalda 'Anthony Waterer' | Anthony Waterer Spiraea | #3 container | 21 | SHRUBS |
| | | | TOTAL | 20 | |

LIBERTY CHASE - 17 LOT TOWNHOUSE
 LANDSCAPE & SITE LIGHTING PLAN
 T.M. #75-A-58, 59
 OPEQUON MAGISTERIAL DISTRICT
 FREDERICK COUNTY, VIRGINIA

151 Windy Hill Lane
 Winchester, Virginia 22602
 Telephone: (540) 682-4185
 Fax: (540) 722-8528
 www.greenwayeng.com



DATE: 2-15-2019
 SCALE: 1" = 30'
 DESIGNED BY: JNT
 FILE NO. 4634T
 SHEET 10 OF 14
 15-19

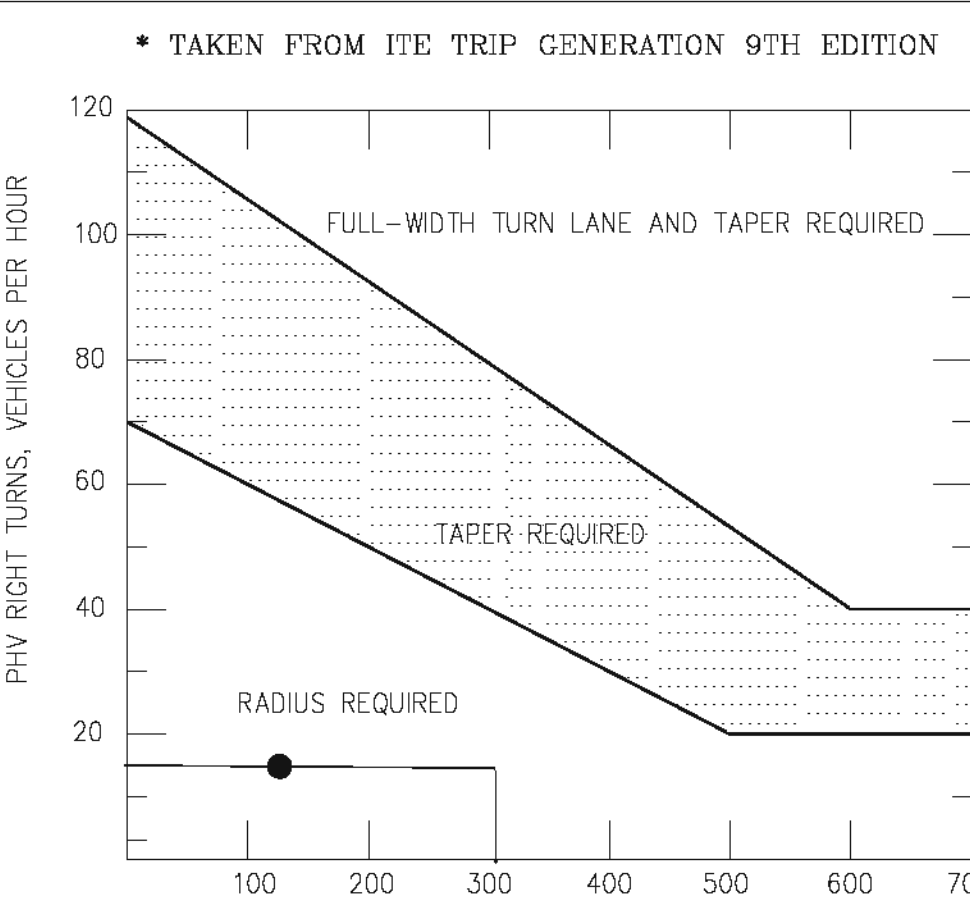
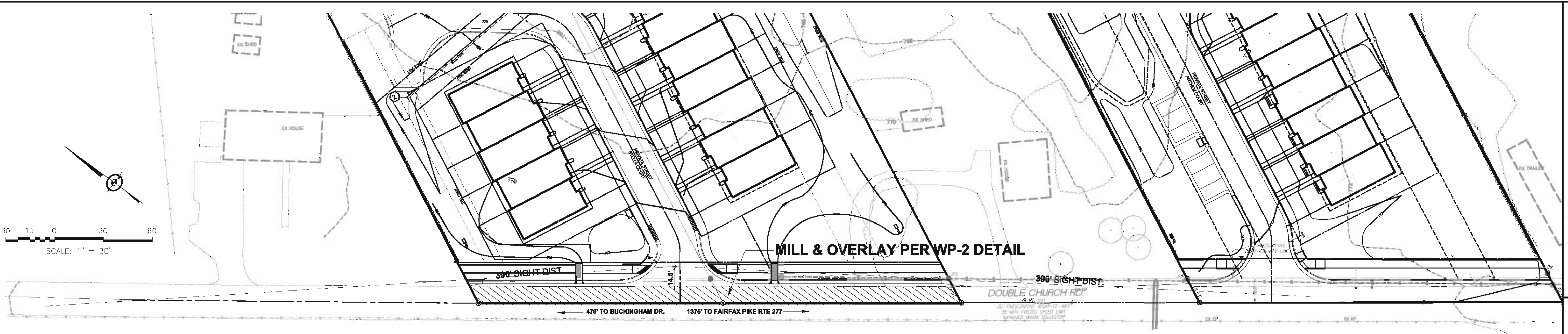
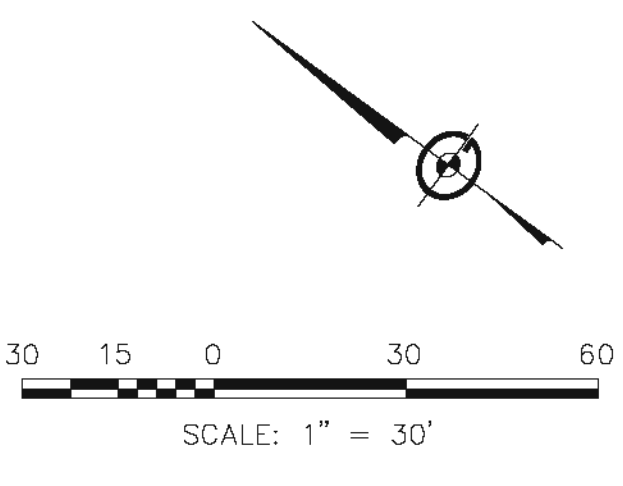
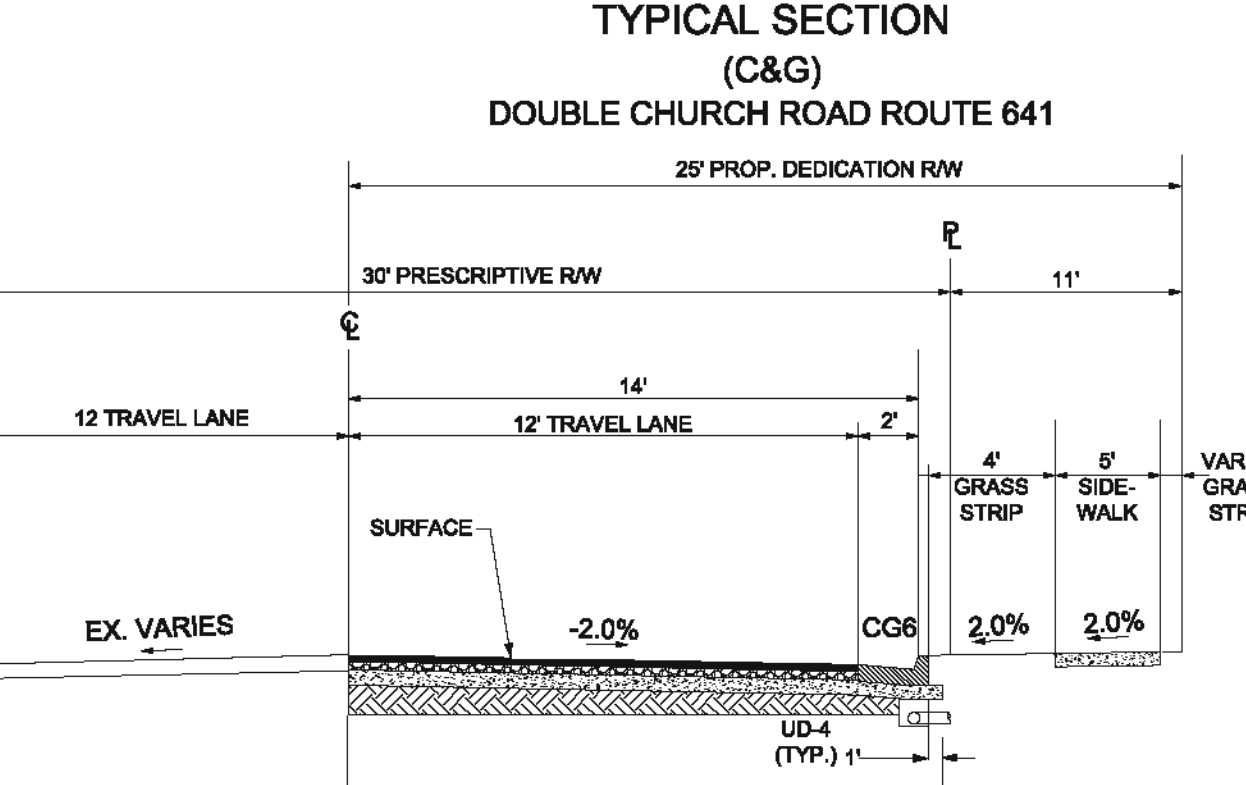

FIGURE 3-26 WARRANTS FOR RIGHT-TURN LANE TREATMENT (2-LANE HIGHWAY AADT (2016)= 2800 trips | Rte 277 to Buckingham Dr

2800 x 11% = 308 PHV
17 Townhomes = 138 VPD x 11% = 15 PHV
50% SOUTH BOUND, AM PHV MAKING RIGHT TURN LANE: 91.5 PHV
Conclusion: BASED ON CHART ABOVE: Radius Required

TRAFFIC ANALYSIS
Guidelines and Tables taken from
ITE 9th EDITION
VDOT AADT (2016)
VDOT Road Design Manual, Appendix F

VDOT NOTES:
*PVMT. DESIGN FOR ENTRANCE IS PRELIMINARY.
FINAL PVMT. DESIGN TO BE BASED ON
FIELD OBTAINED CBR VALUES.
**CONTRACTOR TO VERIFY FULL DEPTH PAVEMENT
ON DOUBLE CHURCH RD. IN PRESENCE OF A VDOT
INSPECTOR. THE PVMT. WIDENING SHALL BEGIN AT
THAT POINT.**
**UD-4 SHALL BE PLACED UNDERNEATH CURBS & GUTTER
ALONG PROPERTY FRONTAGE AND DAYLIGHT TO STD. EW-12**



*PRELIMINARY PVMT. DESIGN
2" SM-9.5A BASE COURSE
3" BM-25 BASE COURSE
8" SUBBASE VDOT STD. 21B

SQUARE TUBE STEEL SIGN POSTS - Square tube steel sign posts shall be fabricated from hot rolled, carbon sheet steel, structural steel quality, conforming to the requirements of ASTM A1011, grade 50 except the yield strength after cool forming shall be 60,000 psi minimum. The steel gauge shall be 14 gauge for the 2 inch by 2 inch post and 10 gauge for the 2 1/2 inch by 2 1/2 inch posts. Posts (inside and outside) shall be galvanized in accordance with the requirements of ASTM A653, Coating Designation G-90. Post shall use an in ground anchor system that provides a stable installation and allows easy replacement of the sign post into the anchor system after vehicular impact. Post shall conform to the breakaway requirements of AASHTO's Standard Specifications for Structural Supports for Highway Signs, Luminaires, and Traffic Signals (1994 Edition including revisions). The Contractor shall provide a copy of the FHWA's acceptance letter indicating compliance with breakaway requirements at the time of catalog submission of the posts. Posts shall have 7/16 inch (+/- 1/64 inch) openings or knockouts spaced 1 inch on centers on all four sides. Post shall be installed in accordance with the manufacturer's recommendations.

TRAFFIC CONTROL DEVICES
*STOP SIGNS SHALL BE 30"x30" R1-1
*STOP BARS SHALL BE 24" WIDE WHITE THERMOPLASTIC
*"DO NOT ENTER" SIGN TO BE R5-1
*EXACT LOCATION OF STOP SIGNS AND STOP BARS TO BE FIELD CHECKED BY VDOT INSPECTOR DURING INSTALLATION.
INFORMATION TAKEN FROM:
MANUAL ON UNIFORM TRAFFIC CONTROL DEVICES 2003 EDITION

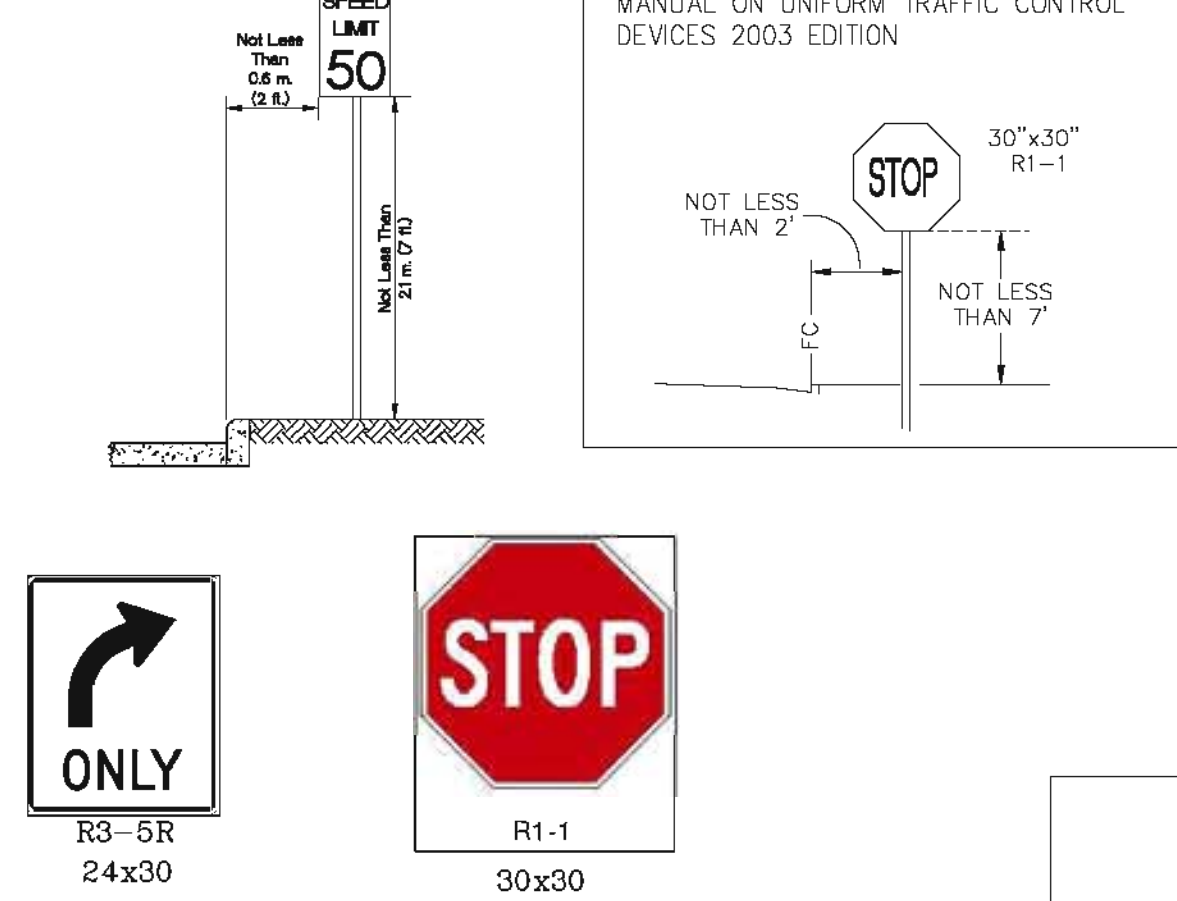

NOTES:
-ALL STOP LINES AS SHOWN SHALL BE 24" WIDE WHITE THERMOPLASTIC.
STREET LIGHT DESIGN DETAILS SHALL CONFORM TO COMMUNITY DESIGN STANDARDS AND SHALL BE INSTALLED PER COUNTY REQUIREMENTS.

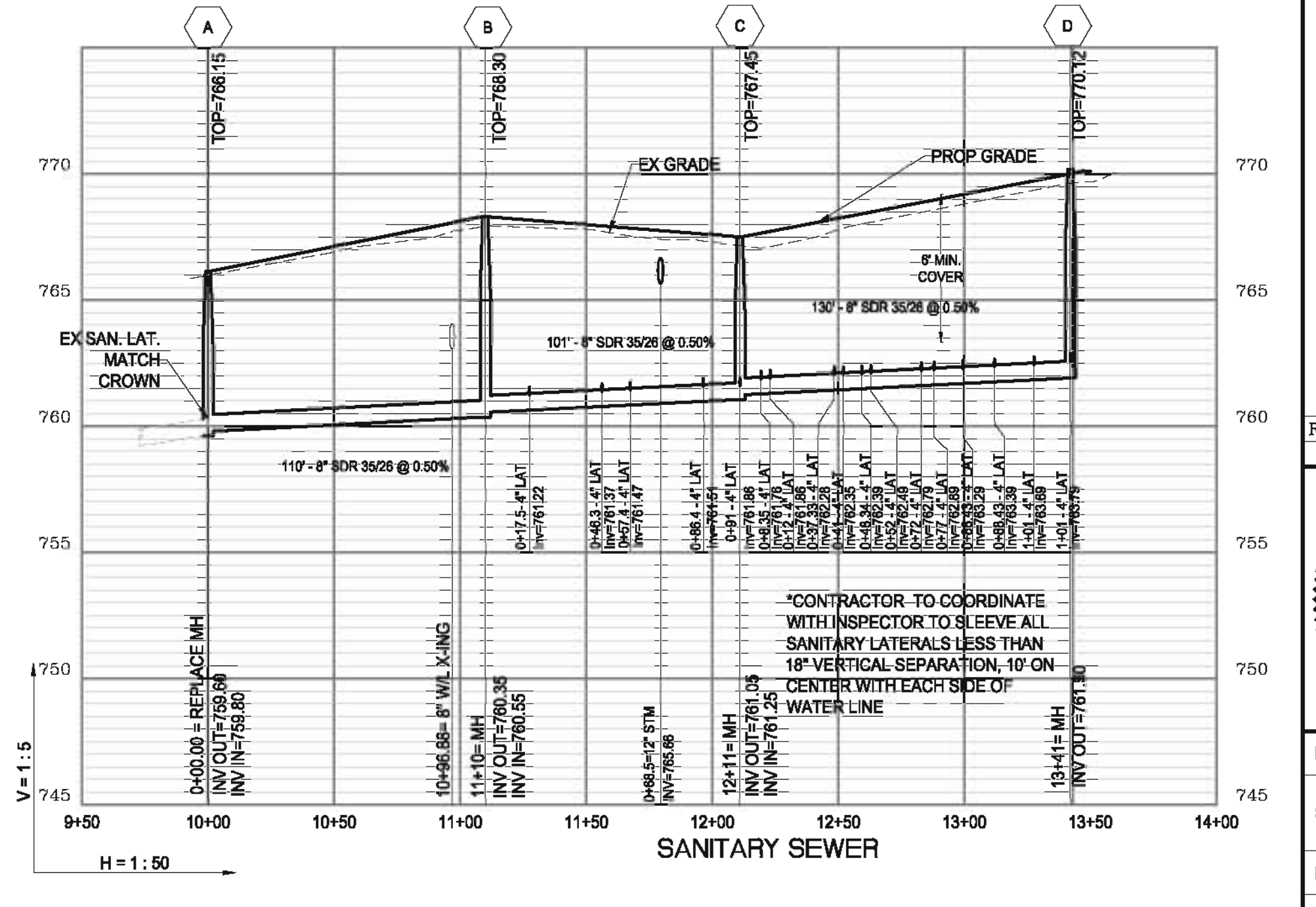
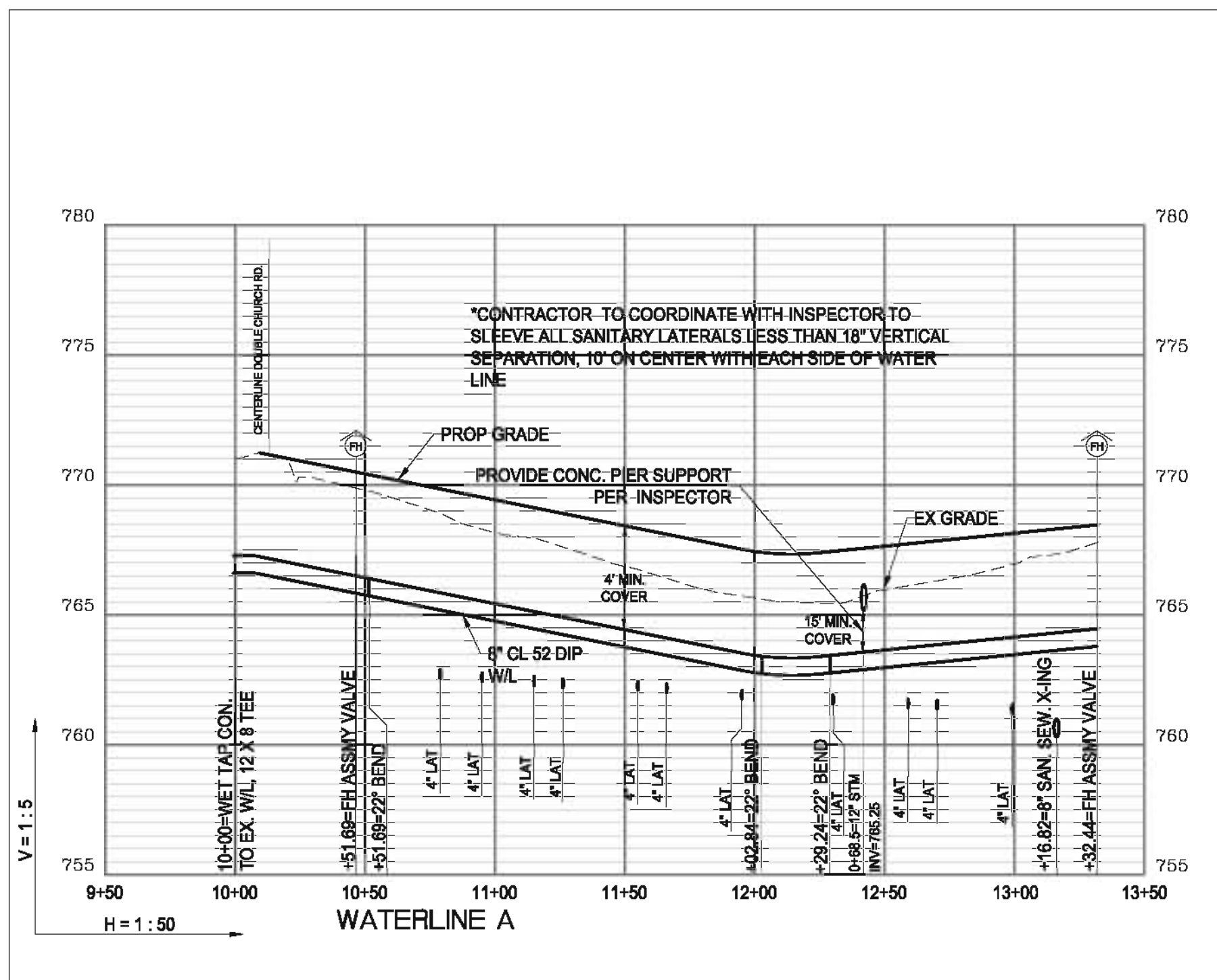
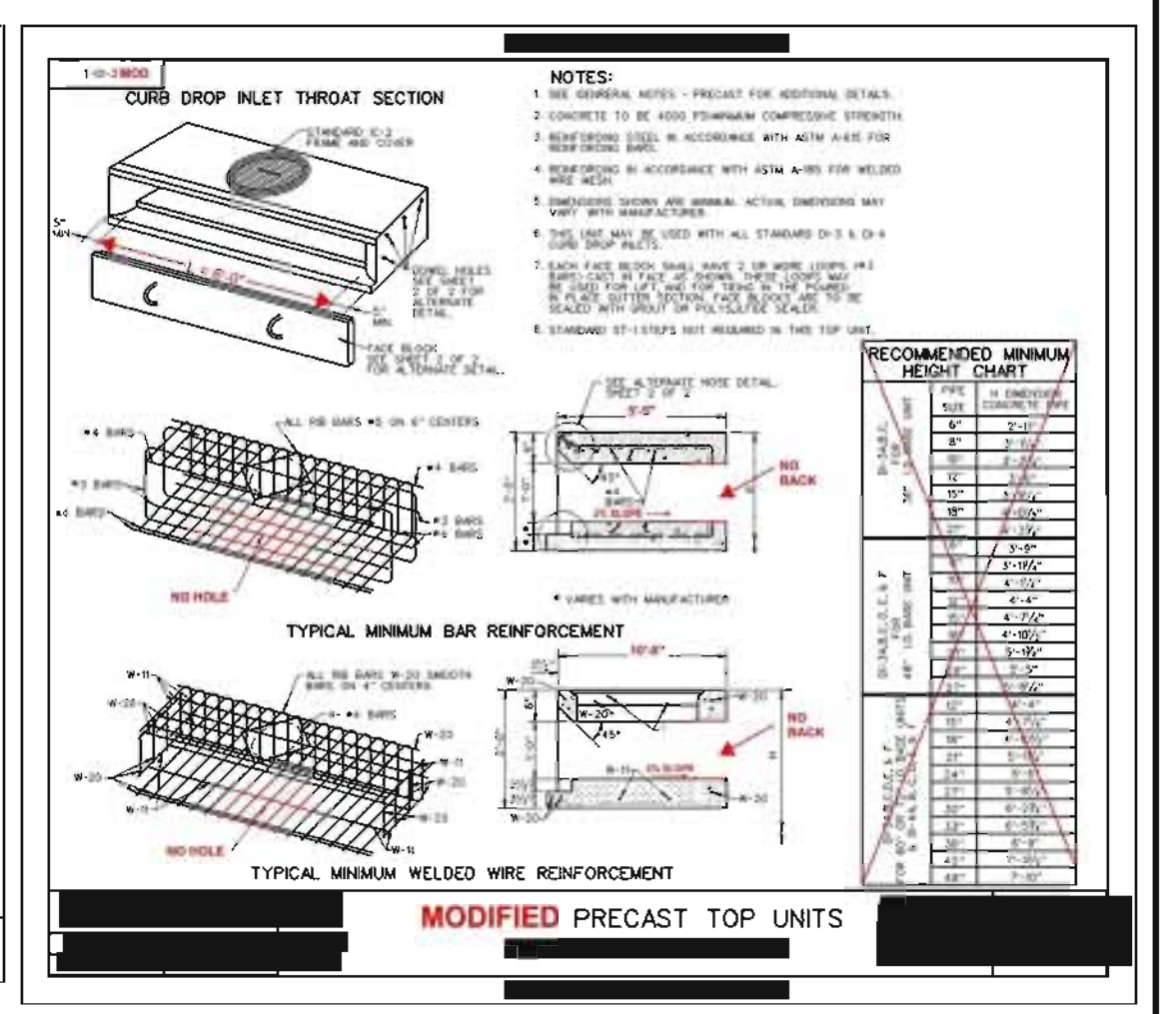
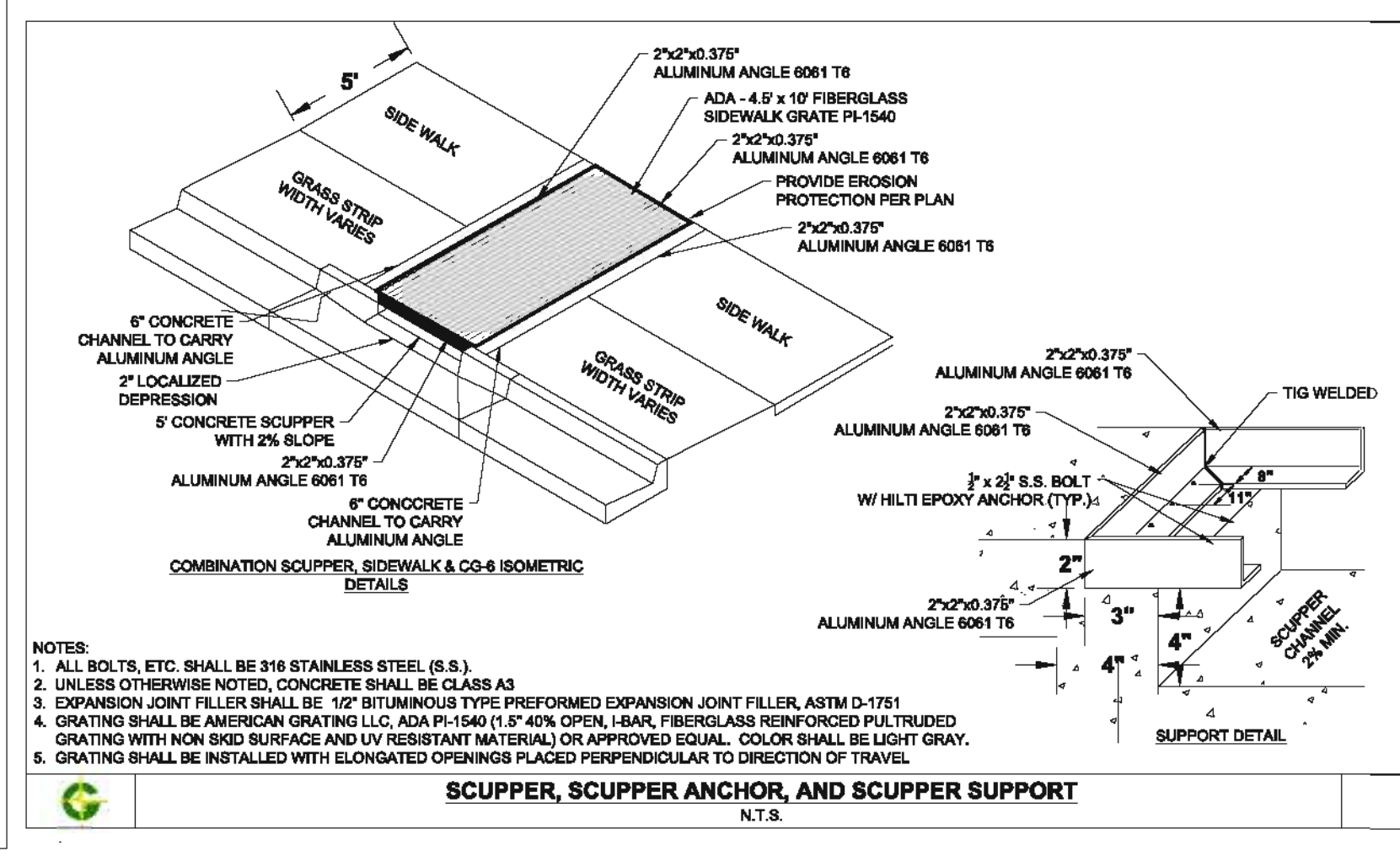
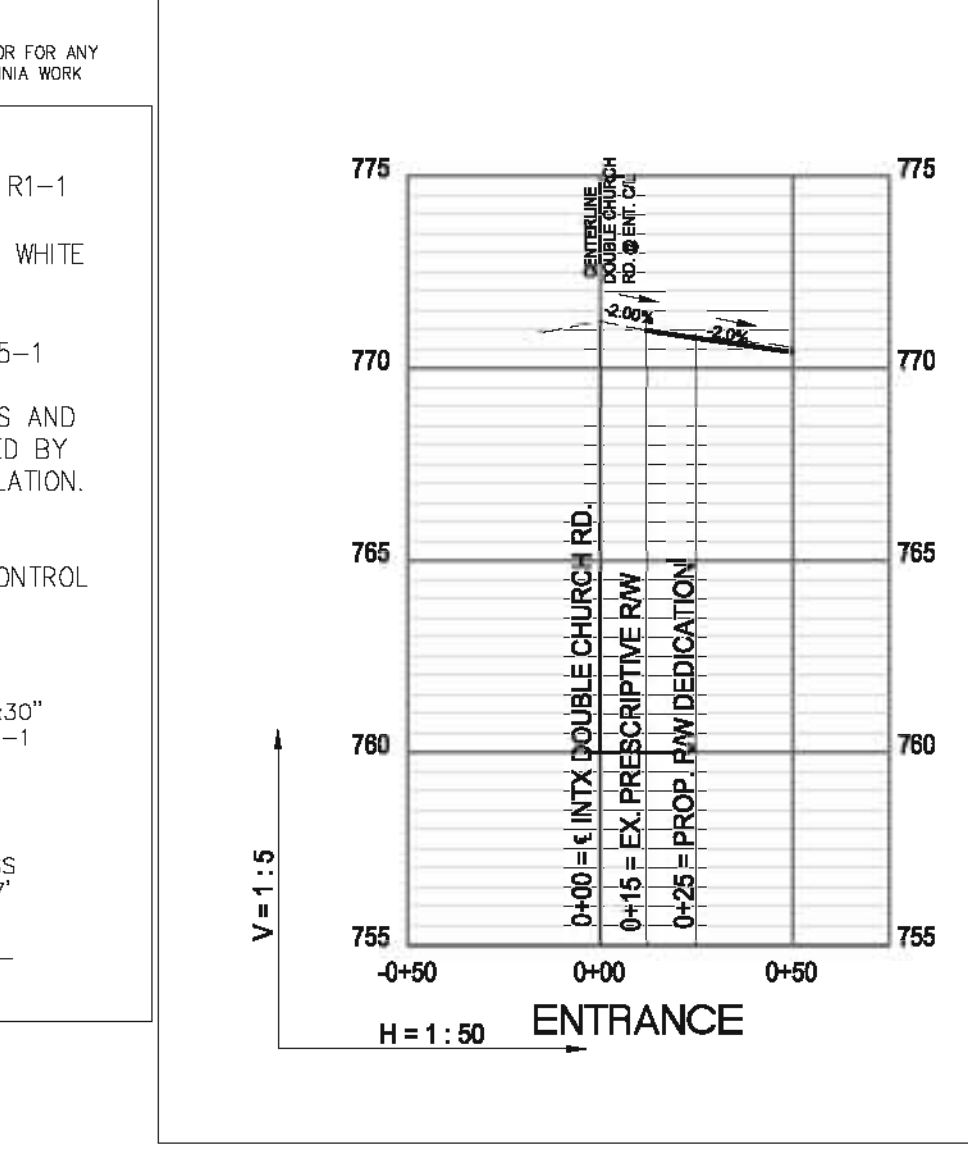
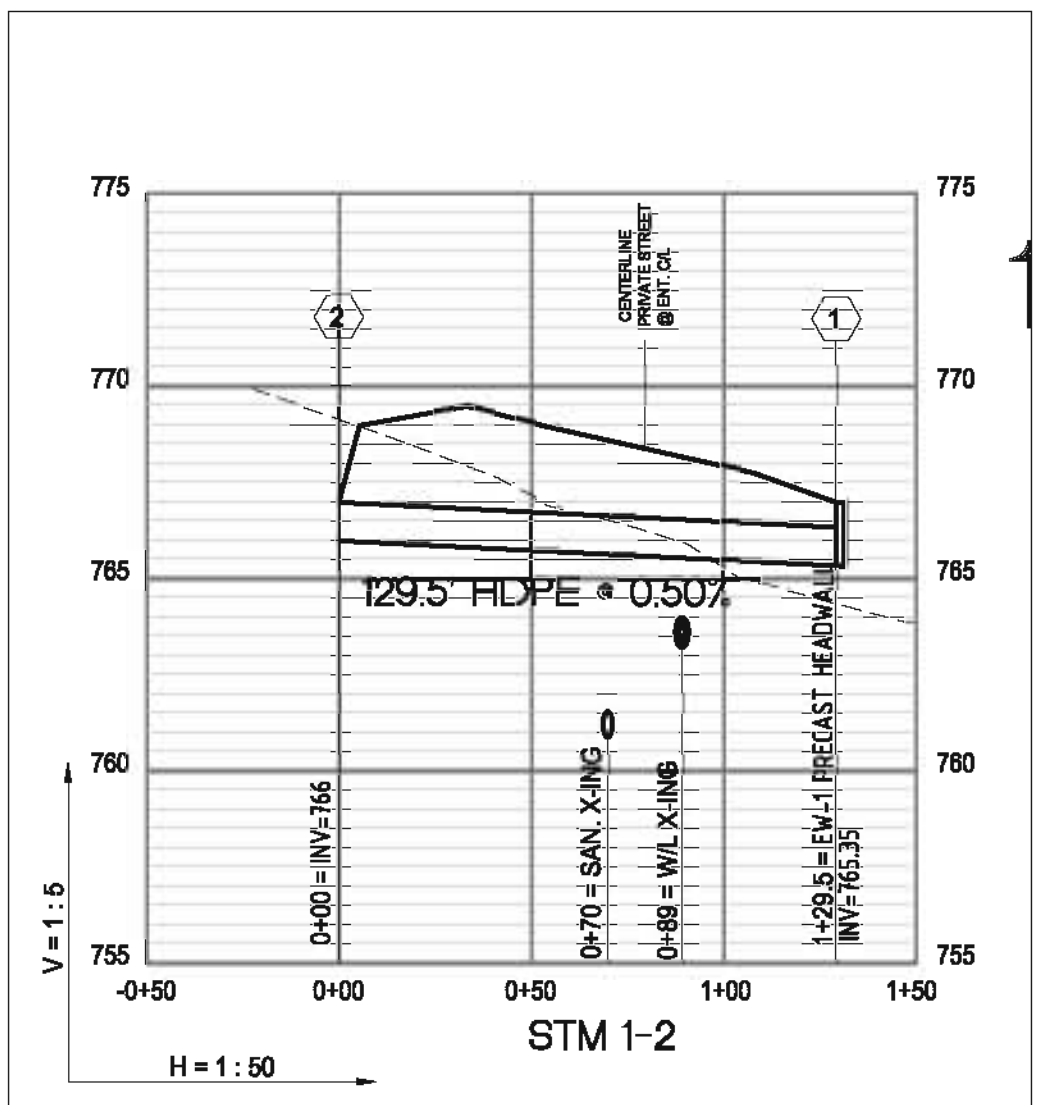

151 Windy Hill Lane
Winchester, Virginia 22602
Telephone: (540) 662-4185
Fax: (540) 722-8528
www.greenwayeng.com

GREENWAY ENGINEERING

PROUDLY SERVING VIRGINIA & WEST VIRGINIA
OFFICES IN WINCHESTER, VA & MARTINSBURG, WV

UTILITY PROFILES
LIBERTY CHASE - 17 LOT TOWNHOUSE
T.M. #75-A-58.59
OPEQUON MAGISTERIAL DISTRICT
FREDERICK COUNTY, VIRGINIA

Rev. No. Date

DATE: 2-15-2019

SCALE: AS SHOWN

DESIGNED BY: JNT

FILE NO. 4634T

SHEET 11 OF 14

15-19

COMMONWEALTH OF VIRGINIA
TUNG NGU ADHIKUSUMA
Lic. No. 28715
2/26/19
PROFESSIONAL ENGINEER

Guidelines referenced from the
2012 Frederick County Fire Prevention Code
APPENDIX D FIRE APPARATUS ACCESS ROADS



D104.3 Remoteness
Where two fire apparatus access roads are required, they shall be placed a distance apart equal to not less than one half of the length of the maximum overall diagonal dimension of the lot or area to be served, measured in a straight line between accesses.

SECTION D105 AERIAL FIRE APPARATUS ACCESS ROADS

D105.1 Where Required

Where the vertical distance between the grade plane and the highest roof surface exceeds 30 feet (9144 mm), approved aerial fire apparatus access roads shall be provided. For purposes of this section, the highest roof surface shall be determined by measurement to the eave of a pitched roof, the intersection of the roof to the exterior wall, or the top of parapet walls, whichever is greater.

D105.2 Width

Aerial fire apparatus access roads shall have a minimum unobstructed width of 26 feet (7925 mm), exclusive of shoulders, in the immediate vicinity of the building or portion thereof.

D105.3 Proximity to building

At least one of the required access roads meeting this condition shall be located within a minimum of 15 feet (4572 mm) and a maximum of 30 feet (9144 mm) from the building, and shall be positioned parallel to one entire side of the building. The side of the building on which the aerial fire apparatus access road is positioned shall be approved by the fire code official.

D105.4 Obstructions

Overhead utility and power lines shall not be located over the aerial fire apparatus access road or between the aerial fire apparatus road and the building. Other obstructions shall be permitted to be placed with the approval of the fire code official.

SECTION D106 MULTIPLE-FAMILY RESIDENTIAL DEVELOPMENTS

D106.1 Projects having more than 100 dwelling units

Multiple-family residential projects having more than 100 dwelling units shall be equipped throughout with two separate and approved fire apparatus access roads.

Exception: Projects having up to 200 dwelling units may have a single approved fire apparatus access road when all buildings, including nonresidential occupancies, are equipped throughout with approved automatic sprinkler systems installed in accordance with Section 903.3.1.1 or 903.3.1.2.

Guidelines referenced from the
2012 Frederick County Fire Prevention Code
APPENDIX D FIRE APPARATUS ACCESS ROADS



SECTION D101 GENERAL

D101.1 Scope
Fire apparatus access roads shall be in accordance with this appendix and all other applicable requirements of the International Fire Code.

SECTION D102 REQUIRED ACCESS

D102.1 Access and loading

Facilities, buildings or portions of buildings hereafter constructed shall be accessible to fire department apparatus by way of an approved fire apparatus access road with an asphalt, concrete or other approved driving surface capable of supporting the imposed load of fire apparatus weighing at least 75,000 pounds (34 050 kg).

SECTION D103 MINIMUM SPECIFICATIONS

D103.1 Access road width with a hydrant

Where a fire hydrant is located on a fire apparatus access road, the minimum road width shall be 26 feet (7925 mm), exclusive of shoulders (See Figure D103.1).

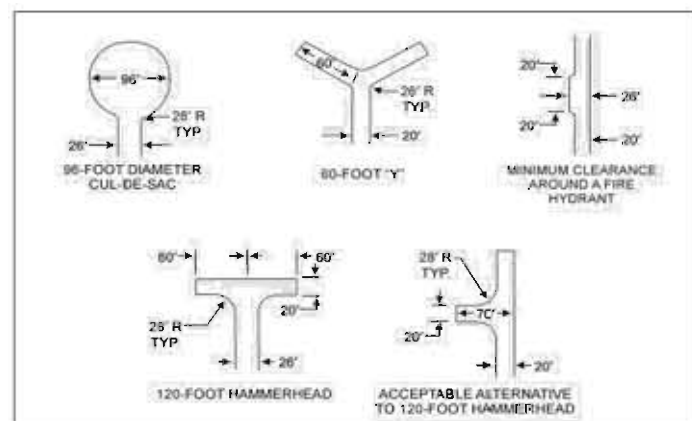

FIGURE D103.1 DEAD-END FIRE APPARATUS ACCESS ROAD TURNAROUND

D103.2 Grade

Fire apparatus access roads shall not exceed 30 percent in grade.
Exception: Grades steeper than 10 percent as approved by the fire chief.

D103.3 Turning radius

The minimum turning radius shall be determined by the fire code official.

D103.4 Dead ends

Dead-end fire apparatus access roads in excess of 150 feet (45 720 mm) shall be provided with width and turnaround provisions in accordance with Table D103.4.

TABLE D103.4 REQUIREMENTS FOR DEAD-END FIRE APPARATUS ACCESS ROADS

| LENGTH (feet) | WIDTH (feet) | Notes Required |
|---------------|--------------|--|
| 0 - 150 | 20 | 120-foot Hammerhead, 60-foot "Y" or 96-foot diameter cut-de-sac-in accordance with Figure D103.1 |
| 151 - 500 | 20 | 120-foot Hammerhead, 60-foot "Y" or 96-foot diameter cut-de-sac-in accordance with Figure D103.1 |
| 501 - 750 | 26 | 120-foot Hammerhead, 60-foot "Y" or 96-foot diameter cut-de-sac-in accordance with Figure D103.1 |
| Over 750 | | Special approval required |

For 10' lot = 304.8 mm.

D103.5 Fire apparatus access road gates

Gates securing the fire apparatus access roads shall comply with all of the following criteria:

- The minimum gate width shall be 20 feet (6096 mm).
- Gates shall be of the swinging or sliding type.
- Construction of gates shall be of materials that allow manual operation by one person.
- Gate components shall be maintained in an operative condition at all times and replaced or repaired when defective.
- Electric gates shall be equipped with a means of opening the gate by fire department personnel for emergency access. Emergency opening devices shall be approved by the fire code official.
- Manual opening gates shall not be locked with a padlock or chain and padlock unless they are capable of being opened by means of forcible entry tools or when a key box containing the key(s) to the lock is installed at the gate location.
- Locking device specifications shall be submitted for approval by the fire code official.
- Electric gate operators, where provided, shall be listed in accordance with UL 325.
- Gates intended for automatic operation shall be designed, constructed and installed to comply with the requirements of ASTM F 2200.

Guidelines referenced from the
2012 Frederick County Fire Prevention Code
APPENDIX D FIRE APPARATUS ACCESS ROADS



D103.6 Signs

Where required by the fire code official, fire apparatus access roads shall be marked with permanent NO PARKING—FIRE LANE signs complying with Figure D103.6. Signs shall have a minimum dimension of 12 inches (305 mm) wide by 18 inches (457 mm) high and have red letters on a white reflective background. Signs shall be posted on one or both sides of the fire apparatus road as required by Section D103.6.1 or D103.6.2.

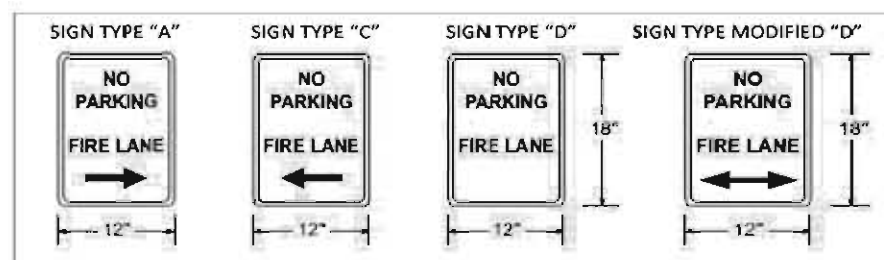

FIGURE D103.6 FIRE LANE SIGNS

D103.6.1 Roads 20 to 26 feet in width

Fire lane signs as specified in Section D103.6 shall be posted on both sides of fire apparatus access roads that are 20 to 26 feet wide (6096 to 7925 mm).

D103.6.2 Roads more than 26 feet in width

Fire lane signs as specified in Section D103.6 shall be posted on one side of fire apparatus access roads more than 26 feet wide (7925 mm) and less than 32 feet wide (9754 mm).

SECTION D104 COMMERCIAL AND INDUSTRIAL DEVELOPMENTS

D104.1 Buildings exceeding three stories or 30 feet in height

Buildings or facilities exceeding 30 feet (9144 mm) or three stories in height shall have at least two means of fire apparatus access for each structure.

D104.2 Buildings exceeding 62,000 square feet in area

Buildings or facilities having a gross building area of more than 62,000 square feet (5760 m²) shall be provided with two separate and approved fire apparatus access roads.

Exception: Projects having a gross building area of up to 124,000 square feet (11 520 m²) that have a single approved fire apparatus access road when all buildings are equipped throughout with approved automatic sprinkler systems.

Guidelines referenced from the
2012 Frederick County Fire Prevention Code
APPENDIX D FIRE APPARATUS ACCESS ROADS



D106.2 Projects having more than 200 dwelling units

Multiple-family residential projects having more than 200 dwelling units shall be provided with two separate and approved fire apparatus access roads regardless of whether they are equipped with an approved automatic sprinkler system.

SECTION D107 ONE- OR TWO-FAMILY RESIDENTIAL DEVELOPMENTS

D107.1 One- or two-family dwelling residential developments

Developments of one- or two-family dwellings where the number of dwelling units exceeds 30 shall be provided with two separate and approved fire apparatus access roads, and shall meet the requirements of Section D104.3.

Exceptions:

1. Where there are more than 30 dwelling units on a single public or private fire apparatus access road and all dwelling units are equipped throughout with an approved automatic sprinkler system in accordance with Section 903.3.1.1, 903.3.1.2 or 903.3.1.3 of the International Fire Code, access from two directions shall not be required.

2. The number of dwelling units on a single fire apparatus access road shall not be increased unless fire apparatus access roads will connect with future development, as determined by the fire code official.

D106 REFERENCED STANDARDS

- ASTM F 2200—05 Standard Specification for Automated Vehicular Gate Construction D103.5
- ICC IFC—12 International Fire Code D101.5, D107.1
- UL 325—02 Door, Drapery, Gate, Louver, and Window Operators and Systems, with Revisions through February 2006 D103.5

Frederick County, VA

Local ordinance referenced from <http://ecode360.com/8705949>

§90-4 General requirements

The following requirements shall apply to all construction or land development activities in areas of the County to which this article applies:

A. Means of access for Fire Department apparatus.

- The means of access for Fire Department apparatus and personnel shall consist of fire lanes, private streets, streets, parking lanes or a combination thereof.
- Parking in any means of access shall not be permitted within 15 feet of a fire hydrant, sprinkler or standpipe connection or in any other manner which will obstruct or interfere with the Fire Department's use of the hydrant or connection.
- "No parking" signs or another designation indicating that parking is prohibited shall be provided at all normal and emergency access points to structures and within 15 feet of each fire hydrant, sprinkler or standpipe connection.

B. Fire lanes.

- The Fire Marshal or his/her designated representative, in concert with the local volunteer fire company, may designate both public and private fire lanes as required for the efficient and effective use of fire apparatus. Said fire lanes shall be marked in a manner prescribed by the Fire Marshal or his/her designated representative. Parking in a designated fire lane shall be controlled by Chapter 158, Vehicles and Traffic, of the Frederick County Code.
- Fire lanes shall be at least 20 feet in width, with the road edge closest to the structure at least 10 feet from the structure, be constructed of a hard all-weather surface adequately designed to support any fire apparatus likely to be operated in such fire lane or be of subsurface construction designed to support the same loads as the above surfaces and be covered with no more than three inches of soil or sod, or both, and be designed with radii of sufficient length to allow for safe turning by any fire apparatus likely to be operated on such fire lane.
- Fire lanes connecting to public streets, roadways or private streets shall be provided with curb cuts extending at least two feet beyond each edge of the fire lane.
- Chains or other barriers may be provided at the entrance to fire lanes or private streets, provided that they are installed according to the requirements of the Authority Having Jurisdiction.

C. Parking lot lanes.

Parking lot lanes shall have a minimum of 15 feet clear width between rows of parked vehicles for vehicular access and movement.

D. Location of structures.

- At least three perimeter walls of all industrial, commercial, public or semipublic or residential structures with three or more dwelling units per structure shall be within 200 feet of a street, fire lane, or private street.
- Structures exceeding 30 feet in height shall not be set back more than 50 feet from a street, fire lane or private street.
- When any combination of private fire-protection facilities, including but not limited to fire-resistant roofs, fire separation walls, space separation and automatic fire-extinguishing systems, is provided, and approved by the Fire Marshal or his/her designated representative as an acceptable alternative, Subsection D(2) shall not apply.
- The Fire Marshal or his/her designated representative may, in concert with the local volunteer fire company, require at least two means of access for fire apparatus to all commercial and industrial structures. Those access ways shall meet the requirements of Subsection B(3).
- Landscaping or other obstructions shall not be placed around structures or hydrants in a manner so as to impair or impede accessibility for fire-fighting and rescue operations.

E. Water supply.

- Water supply systems shall be designed so as to be capable of supplying at least 1,000 gallons per minute at 20 pounds per square inch. Water supplies shall be made available and operational before combustibles are on site during construction.
- In areas developed with single-family detached or duplex dwelling units, there shall be a fire hydrant within 400 feet of all units. In areas developed with three to five dwelling units per structure, there shall be a hydrant within 300 feet of all units. In areas developed with six or more dwelling units per structure, there shall be at least two hydrants within 300 feet of all units. In areas developed with industrial or commercial development(s), there shall be a hydrant within 300 feet of all portions of any structure. Where one hydrant is dedicated to the operation of a standpipe system, there shall be at least one other hydrant meeting the distance requirements set forth above. The hydrant dedicated to the operation of the standpipe system shall not be farther than 50 feet from the standpipe. Distance measurements under this section shall be along center-line roadway surfaces or along surfaces meeting the requirements of a fire lane (designated or undesignated) where appropriate, but in all cases access to each hydrant shall be directly from a roadway and/or fire lane.
- Fire hydrants shall be marked in accordance with the Frederick County Sanitation Authority policy.
- Fire hydrants located in parking areas shall be protected by barriers that will prevent physical damage from vehicles.
- Fire hydrants shall be located within three feet of the curb line of fire lanes, streets or private streets when installed along such access ways.
- Fire hydrants shall be installed in accordance with the standards of the Frederick County Sanitation Authority.
- Threads on fire hydrant outlets shall conform to Frederick County Sanitation Authority policy.
- Fire hydrants shall be supplied by not less than a six-inch diameter main.

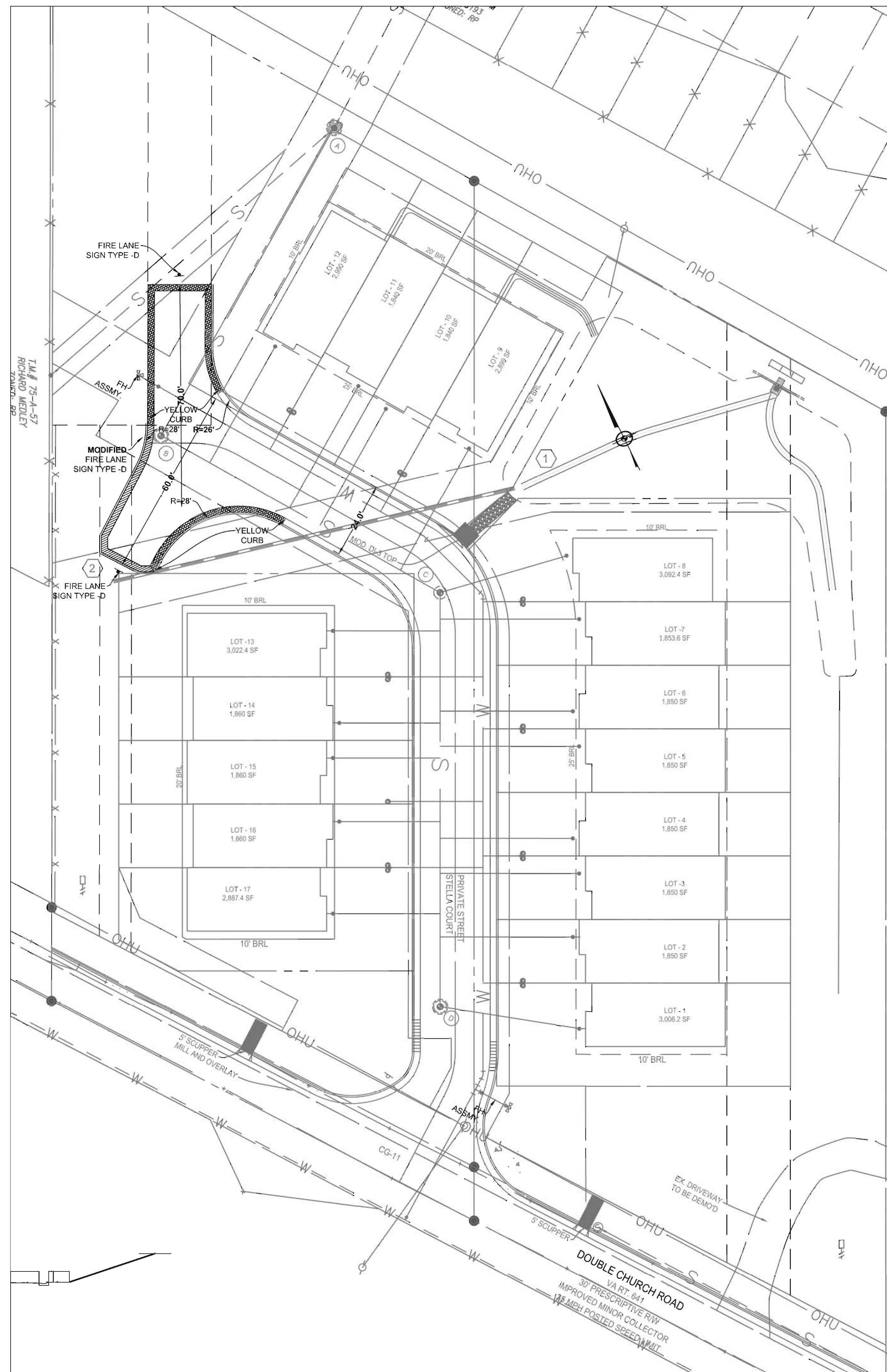

UTILITY PLAN

SCALE: 1" = 20'

151 Winky Hill Lane
Winchester, Virginia 22602
Telephone: (540) 662-4185
Fax: (540) 722-9528
www.greenwayeng.com

PROUDLY SERVING VIRGINIA & WEST VIRGINIA
OFFICES IN WINCHESTER, VA & MARTINSBURG, WV

LIFE SAFETY PLAN

LIBERTY CHASE - 17 LOT TOWNHOUSE

T.M. #75-A-58, 59

OPEQUON MAGISTERIAL DISTRICT
FREDERICK COUNTY, VIRGINIA

| | |
|--------------|-----------|
| Rev. No. | Date |
| | |
| | |
| DATE: | 2-15-2019 |
| SCALE: | N/A |
| DESIGNED BY: | JNT |
| FILE NO. | 4634T |
| SHEET | 12 OF 14 |
| | 15-19 |

